

Quick Start Guide

UNO-3272G 電腦

Intel® Celeron J1900 processors
Embedded Automation
Computer, with PCIe/PCI
Extension slots

ADVANTECH

Enabling an Intelligent Planet

Copyright

The documentation and the software included with this product are copyrighted 2019 by Advantech Co., Ltd. All rights are reserved. Advantech Co., Ltd. reserves the right to make improvements in the products described in this manual at any time without notice. No part of this manual may be reproduced, copied, translated or transmitted in any form or by any means without the prior written permission of Advantech Co., Ltd. Information provided in this manual is intended to be accurate and reliable. However, Advantech Co., Ltd. assumes no responsibility for its use, nor for any infringements of the rights of third parties, which may result from its use.

Acknowledgements

Intel® is trademarks of Intel Corporation.

Microsoft Windows and MS-DOS are registered trademarks of Microsoft Corp.

C&T is a trademark of Chips and Technologies, Inc.

All other product names or trademarks are properties of their respective owners.

Support

For more information on this and other Advantech products, please visit our websites at: <http://www.advantech.com>

For technical support and service, please visit our support website at:

<http://support.advantech.com/>

This manual applies to the below model which is abbreviated as UNO-3272G products in this article.

*Model number:

UNO-3272G-J021AE

UNO-3272G

UNO3272GJ0211901-T, UNO3272GJ0211902-T, UNO3272GJ0211903-T,
UNO3272GJ0211904-T, UNO3272GJ0211905-T, UNO3272GJ0211906-T
UNO3272GJ0212001-T, UNO3272GJ0212002-T, UNO3272GJ0212003-T,
UNO3272GJ0212004-T, UNO3272GJ0212005-T, UNO3272GJ0212006-T,
UNO3272GJ0212101-T, UNO3272GJ0212102-T, UNO3272GJ0212103-T,
UNO3272GJ0212104-T, UNO3272GJ0212105-T, UNO3272GJ0212106-T,
UNO3272GJ0212201-T, UNO3272GJ0212202-T, UNO3272GJ0212203-T,
UNO3272GJ0212204-T, UNO3272GJ0212205-T, UNO3272GJ0212206-T,
UNO3272GJ0212301-T, UNO3272GJ0212302-T, UNO3272GJ0212303-T,
UNO3272GJ0212304-T, UNO3272GJ0212305-T, UNO3272GJ0212306-T,
UNO3272GJ0212401-T, UNO3272GJ0212402-T, UNO3272GJ0212403-T,
UNO3272GJ0212404-T, UNO3272GJ0212405-T, UNO3272GJ0212406-T,
UNO3272GJ0212501-T, UNO3272GJ0212502-T, UNO3272GJ0212503-T,
UNO3272GJ0212504-T, UNO3272GJ0212505-T, UNO3272GJ0212506-T,

PN: 2003272G20

Printed in Taiwan

Edition 1

July 2019

Product Warranty (2 years)

Advantech warrants to you, the original purchaser, that each of its products will be free from defects in materials and workmanship for two years from the date of purchase.

This warranty does not apply to any products which have been repaired or altered by persons other than repair personnel authorized by Advantech, or which have been subject to misuse, abuse, accident or improper installation. Advantech assumes no liability under the terms of this warranty as a consequence of such events.

Because of Advantech's high quality-control standards and rigorous testing, most of our customers never need to use our repair service. If an Advantech product is defective, it will be repaired or replaced at no charge during the warranty period. For out-of-warranty repairs, you will be billed according to the cost of replacement materials, service time and freight. Please consult your dealer for more details.

If you think you have a defective product, follow these steps:

1. Collect all the information about the problem encountered. (For example, CPU speed, Advantech products used, other hardware and software used, etc.) Note anything abnormal and list any onscreen messages you get when the problem occurs.
2. Call your dealer and describe the problem. Please have your manual, product, and any helpful information readily available.
3. If your product is diagnosed as defective, obtain an RMA (return merchandise authorization) number from your dealer. This allows us to process your return more quickly.
4. Carefully pack the defective product, a fully-completed Repair and Replacement Order Card and a photocopy proof of purchase date (such as your sales receipt) in a shippable container. A product returned without proof of the purchase date is not eligible for warranty service.
5. Write the RMA number visibly on the outside of the package and ship it prepaid to your dealer.

Declaration of Conformity

CE

This product has passed the CE test for environmental specifications when shielded cables are used for external wiring. We recommend the use of shielded cables. This kind of cable is available from Advantech. Please contact your local supplier for ordering information.

FCC Class A

Note: This equipment has been tested and found to comply with the limits for a Class A digital device, pursuant to part 15 of the FCC Rules. These limits are designed to provide reasonable protection against harmful interference when the equipment is operated in a commercial environment. This equipment generates, uses, and can radiate radio frequency energy and, if not installed and used in accordance with the instruction manual, may cause harmful interference to radio communications. Operation of this equipment in a residential area is likely to cause harmful interference in which case the user will be required to correct the interference at his own expense.

警告使用者：這是甲類資訊產品，在居住的環境中使用時，可能會造成射頻干擾，在這種情況下，使用者會被要求採取某些適當對策。本產品於國內裝置使用時，其電源

僅限使用機架電源模組所提供直流電源輸入，不得使用交流電源及附加其他電源轉換裝置提供店源，其電源輸入電壓及電流請依說明書規定使用

Technical Support and Assistance

1. Visit the Advantech web site at <http://support.advantech.com> where you can find the latest information about the product.
2. Contact your distributor, sales representative, or Advantech's customer service center for technical support if you need additional assistance. Please have the following information ready before you call:
 - Product name and serial number
 - Description of your peripheral attachments
 - Description of your software (operating system, version, application software, etc.)
 - A complete description of the problem
 - The exact wording of any error messages

Safety Precaution - Static Electricity

Follow these simple precautions to protect yourself from harm and the products from damage.

- To avoid electrical shock, always disconnect the power from your PC chassis before you work on it. Don't touch any components on the CPU card or other cards while the PC is on.
- Disconnect power before making any configuration changes. The sudden rush of power as you connect a jumper or install a card may damage sensitive electronic components.

Safety Instructions

1. Read these safety instructions carefully.
2. Keep this User Manual for later reference.
3. Disconnect this equipment from any AC outlet before cleaning. Use a damp cloth. Do not use liquid or spray detergents for cleaning.
4. For plug-in equipment, the power outlet socket must be located near the equipment and must be easily accessible.
5. Keep this equipment away from humidity.
6. Put this equipment on a reliable surface during installation. Dropping it or letting it fall may cause damage.
7. The openings on the enclosure are for air convection. Protect the equipment from overheating. **DO NOT COVER THE OPENINGS.**
8. Make sure the voltage of the power source is correct before connecting the equipment to the power outlet.
9. Position the power cord so that people cannot step on it. Do not place anything over the power cord.
10. All cautions and warnings on the equipment should be noted.
11. If the equipment is not used for a long time, disconnect it from the power source to avoid damage by transient overvoltage.
12. Never pour any liquid into an opening. This may cause fire or electrical shock.
13. Never open the equipment. For safety reasons, the equipment should be opened only by qualified service personnel.
14. If one of the following situations arises, get the equipment checked by service personnel:
 - The power cord or plug is damaged.
 - Liquid has penetrated into the equipment.
 - The equipment has been exposed to moisture.
 - The equipment does not work well, or you cannot get it to work according to the user's manual.
 - The equipment has been dropped and damaged.
 - The equipment has obvious signs of breakage.
15. **DO NOT LEAVE THIS EQUIPMENT IN AN ENVIRONMENT WHERE THE STORAGE TEMPERATURE MAY GO BELOW -20° C (-4° F) OR ABOVE 60° C (140° F). THIS COULD DAMAGE THE EQUIPMENT. THE EQUIPMENT SHOULD BE IN A CONTROLLED ENVIRONMENT.**
16. Batteries are at risk of exploding if incorrectly replaced. Replace only with the same or equivalent type as recommended by the manufacturer. Discard used batteries according to the manufacturer's instructions.
17. Danger d'explosion si la batterie est mal remplacé. Remplacer uniquement par le même type ou équivalent recommandé par le fabricant. Jeter les piles usagées selon les instructions du fabricant.
18. The sound pressure level at the operator's position according to IEC 704-1:1982 is no more than 70 dB (A).

DISCLAIMER: This set of instructions is given according to IEC 704-1. Advantech disclaims all responsibility for the accuracy of any statements contained herein.

Consignes de sécurité

1. Lire attentivement les instructions de sécurité.
2. Conserver ce manuel pour utilisation ultérieure,
3. Débranchez cet équipement de toute prise secteur avant de le nettoyer. Utilisez seulement un chiffon humide. N'utilisez pas de détergent liquide ou pulvérisé pour le nettoyage.
4. Gardez cet équipement à l'abri de l'humidité.
5. Placez cet équipement sur une surface fiable pendant l'installation. Le faire ou bien le laisser tomber peut causer des dégâts.
6. Les ouvertures sur l'enceinte servent à la convection de l'air. Protégez l'équipement contre la surchauffe. **NE COUVREZ PAS LES OUVERTURES.**
7. Assurez-vous que la tension de la source d'alimentation est correcte avant de connecter l'équipement à l'alimentation.
8. Placez le câble d'alimentation de manière à ce que personne ne puisse marcher dessus. Ne placez rien sur le câble d'alimentation.
9. Toutes les mises en garde et tous les avertissements sur l'équipement doivent être notés.
10. Si l'équipement n'est pas utilisé pendant une longue période, débranchez-le de la source d'alimentation pour éviter tout endommagement dû à une surtension transitoire.
11. Ne jamais verser de liquide dans une ouverture. Cela pourrait provoquer un incendie ou un choc électrique.
12. N'ouvrez jamais l'équipement. Pour des raisons de sécurité, l'équipement doit être ouvert uniquement par du personnel qualifié.
13. Si l'une des situations suivantes se présente, faites vérifier l'équipement par le personnel de service:
 - Un liquide a pénétré dans l'équipement.
 - L'équipement a été exposé à l'humidité.
 - L'équipement ne fonctionne pas bien, ou vous ne pouvez pas le faire fonctionner selon le manuel de l'utilisateur.
 - L'équipement est tombé et endommagé.
 - L'équipement présente des signes évidents de rupture.
14. **NE LAISSEZ PAS CET ÉQUIPEMENT DANS UN ENVIRONNEMENT OU LA TEMPÉRATURE DE STOCKAGE PEUT ÊTRE INFÉRIEURE À -20 ° C (-4 ° F) OU BIEN SUPÉRIEURE À 60 ° C (140 ° F). CECI POURRAIT ENDOMMAGER L'EQUIPEMENT. L'ÉQUIPEMENT DEVRAIT ÊTRE DANS UN ENVIRONNEMENT CONTRÔLÉ.**

安全指示

1. 請仔細閱讀此安全操作說明。
2. 請妥善保存此用戶手冊供日後參考。
3. 用濕抹布清洗設備前，請確認拔除電源線。請勿使用液體或去污噴霧劑清洗設備。
4. 對於使用電源線的設備，設備周圍必須有容易接觸到的電源插座。
5. 請勿在潮濕環境中試用設備。
6. 請在安裝前確保設備放置在可靠的平面上，意外摔落可能會導致設備損壞。
7. 設備機殼的開孔適用於空氣對，從而防止設備過熱。**請勿覆蓋開孔。**
8. 當您連接設備到電源插座前，請確認電源插座的電壓符合要求。
9. 請將電源線佈置在人們不易絆倒的位置，請勿在電源線上覆蓋任何雜物。
10. 請注意設備上所有的警告標示。
11. 如果長時間不使用設備，請拔除與電源插座的連結，避免設備被超標的電壓波動損壞。
12. 請勿讓任何液體流入通風口，以免引起火災或短路。
13. 請勿自行打開設備。為了確保您的安全，請透過經認證的工程師來打開設備。
14. 如遇下列情況，請由專業人員維修：
 - 電源線或插頭損壞；
 - 設備內部有液體流入；
 - 設備曾暴露在過度潮濕環境中使用；
 - 設備無法正常工作，或您無法透過用戶手冊來正常工作；
 - 設備摔落或損壞；
 - 設備有明顯外觀損；
15. 請勿將設備放置在超出建議溫度範圍的環境，即不要低於 $-20\text{ }^{\circ}\text{C}$ ($-4\text{ }^{\circ}\text{F}$) 或高於 $60\text{ }^{\circ}\text{C}$ ($140\text{ }^{\circ}\text{F}$)，否則可能會造成設備損壞。
16. 注意：若電池更換不正確，將有爆炸危險。因此，只可以使用製造商推薦的同一種或者同等型號的電池進行替換。請按照製造商的指示處理舊電池。
17. 本產品於國內裝置使用時，其電源僅限使用機架電源模組所提供直流電源輸入，不得使用交流電源及附加其他電源轉換裝置提供電源，其電源輸入電壓及電流請依說明書規定使用。
18. 根據 IEC 704 - 1:1982 規定，操作員所在位置音量不可高於 70 分貝。
19. 限制區域：請勿將設備安裝於限制區域使用。
20. 免責聲明：請安全訓示符合 IEC 704 - 1 要求。研華公司對其內容之準確性不承擔任何法律責任。

Warnings, Cautions and Notes

Warning! Warnings indicate conditions, which if not observed, can cause personal injury!



Caution! Cautions are included to help you avoid damaging hardware or losing data. e.g.



There is a danger of a new battery exploding if it is incorrectly installed. Do not attempt to recharge, force open, or heat the battery. Replace the battery only with the same or equivalent type recommended by the manufacturer. Discard used batteries according to the manufacturer's instructions.

Note! Notes provide optional additional information.



限用物質含有情況標示聲明書

設備名稱：電腦 Equipment name	型號（型式）： UNO-3272G(系列型號請參見手冊載明型號) Type designation (Type)					
單元 Unit	限用物質及其化學符號 Restricted substances and its chemical symbols					
	鉛 Lead (Pb)	汞 Mercury (Hg)	鎘 Cadmium (Cd)	六價鉻 Hexavalent chromium (Cr+6)	多溴聯苯 Polybromina ted biphenyls (PBB)	多溴二苯醚 Polybrominat ed diphenyl ethers (PBDE)
電路板	—	○	○	○	○	○
內外殼	○	○	○	○	○	○
線材	○	○	○	○	○	○
其它固定組件 (螺絲, 螺柱)	—	○	○	○	○	○
記憶體	—	○	○	○	○	○
蜂鳴器	○	○	○	○	○	○
<p>備考 1. “超出 0.1 wt %” 及 “超出 0.01 wt %” 係指限用物質之百分比含量超出百分比含量基準值。 Note 1: “Exceeding 0.1 wt %” and “exceeding 0.01 wt %” indicate that the percentage content of the restricted substance exceeds the reference percentage value of presence condition.</p> <p>備考 2. “○” 係指該項限用物質之百分比含量未超出百分比含量基準值。 Note 2: “○” indicates that the percentage content of the restricted substance does not exceed the percentage of reference value of presence.</p> <p>備考 3. “—” 係指該項限用物質為排除項目。 Note 3: The “—” indicates that the restricted substance corresponds to the exemption.</p>						

申請商：研華股份有限公司

地址：台北市內湖區瑞光路 26 巷 20 弄 1 號

電話：02-27927812

Chapter 1	Overview.....	1
1.1	Introduction	2
1.2	Hardware Specifications	2
1.2.1	General	2
1.2.2	Display	2
1.2.3	Ethernet	2
1.3	Chipset.....	3
1.3.1	Functional specification.....	3
1.4	Mechanical Specifications.....	4
1.4.1	Dimensions	4
	Figure 1.1 Dimensions.....	4
1.4.2	Weight.....	4
1.5	Power Requirements.....	4
1.5.1	System power	4
1.5.2	RTC battery.....	4
1.6	Environment Specification.....	4
1.6.1	Operating temperature.....	4
1.6.2	System safety certification test temperature	4
1.6.3	Relative humidity.....	4
1.6.4	Storage temperature	4
1.6.5	Vibration during operation.....	5
1.6.6	Shock during operation	5
1.6.7	Safety.....	5
1.6.8	EMC	5

Chapter 2	H/W Installation.....	7
2.1	Introduction	8
	Figure 2.1 Motherboard Connector and jumper locations (top side) 8	
	Figure 2.2 Motherboard Connector and jumper locations (rear side).....	9
	Table 2.1: Motherboard Connector.....	9
	Figure 2.3 PCIe card connector locations.....	10
	Table 2.2: PCIE Connector.....	10
	Figure 2.4 COM card connector locations	10
	Table 2.3: COM Connector.....	11
2.2	Jumpers	11
2.2.1	Jumper list.....	11
	Table 2.4: Jumper List (motherboard)	11
2.3	Connectors.....	12
2.3.1	External I/O Connectors.....	12
	Figure 2.5 UNO-3272G Front View	12
	Figure 2.6 COM Connector.....	13
	Table 2.5: COM Connector Pin Assignments	13
	Figure 2.7 LAN Connector	14
	Table 2.6: Ethernet Connector Pin Assignments.....	14
	Table 2.7: LED Indicators	14
	Figure 2.8 Audio Connector	15
	Table 2.8: Audio Connector Pin Assignments	15
	Figure 2.9 USB 2.0 Connector.....	15
	Table 2.9: USB 2.0 connector Pin Assignments.....	15
	Figure 2.10 USB 3.0 Connector.....	15
	Table 2.10: USB 3.0 connector Pin Assignments.....	15
	Figure 2.11 VGA Connector	16
	Table 2.11: VGA Connector Pin Assignments.....	16
	Figure 2.12 HDMI Connector	16
	Table 2.12: HDMI Connector Pin Assignments	16

	Figure 2.13 Power Connector.....	17
	Table 2.13: Pin Assignments for Power Connector Pin Header..	17
	Table 2.14: DI/ DO Pin Assignments.....	17
	Table 2.15: DI/DO switch	18
	Figure 2.14 Isolated DI Dry connection	18
	Figure 2.15 Isolated DI Wet connection	19
	Figure 2.16 Isolated Digital Output Connection.....	19
2.3.2	Internal I/O Connectors.....	20
	Table 2.16: PCIE Connector Pin Assignments.....	20
2.4	Installation.....	20
2.4.1	HDD installation	20
2.4.2	Memory & M.2 storage installation	23
2.4.3	iDOOR Installation	24
2.4.4	DI/O card Installation (Optional)	25
2.4.5	PCI/ PCIe Installation (Optional).....	27
2.4.6	FAN-kit Installation (Optional).....	28
2.4.7	Riser card (change) Installation	30
2.4.8	Mounting kit Installation (Optional)	31

Chapter 1

Overview

This chapter provides an overview of UNO-3272G' specifications.

Sections include:

- Introduction
- Hardware specification
- Chassis dimensions
- Accessories

1.1 Introduction

Advantech Embedded Automation PC UNO-3272G models are configured with Intel® Celeron® J1900 2.0GHz processor and 4G RAM. It supports two PCI or PCI express slots, which can fulfill extensive requirements in various applications.

The UNO-3272G provide a rich array of interfaces, including 4 x USB, 2 x GigaLAN, 2 x RS-232/422/485, and 2 x RS-232 ports as well as VGA and HDMI display interfaces, UNO-3272G is designed to deliver high reliability and maximum flexibility for industrial automation applications. The provision of up to 2 expansion slots (2 x PCIe1 or 2 x PCI) supports the integration of modular peripherals and ensures flexible installation in diverse cabinet configurations.

With support for multiple drivers and operating systems, including Windows 7, Windows 10, and Linux, users can easily integrate applications on application-ready platforms in order to offer versatile functions for diverse requirements.

1.2 Hardware Specifications

1.2.1 General

- **CPU:** Intel® Celeron® J1900 2.0GHz processor
- **Memory:** Built-in 4GB DDR3L 1333 MHz (Dual 204pin SODIMM DDR3L socket, up to 8GB)
- **Storage:**
 - Supports 1 drive bay space for SATA 2.5" HDD/SSD
 - Supports 1 x M.2 B-key (2242) up to 512GB
 - Supports 1 x CFast slot (By iDOOR Technology)
- **Graphic:** VGA + HDMI
- **Ethernet Port:** 2 x RJ45
- **TPM:** TPM2.0
- **Watchdog Timer:** Single chip Watchdog 255-level interval timer, setup by software
- **I/O Interface:** 2x RS232/422/485, 2x RS-232
- **USB:**
 - 3x USB2.0,
 - 1x USB3.0
- **Audio:** Line-out
- **Expansion interface**
 - 1x full-size mini PCIe (via USIM)

1.2.2 Display

- **Resolution:**
 - VGA: Supports up to 1920 x 1080 @ 60 Hz 24bpp
 - HDMI: Supports up to 1920 x 1080 @ 60 Hz 24 bpp

1.2.3 Ethernet

- **Chipset:**
 - 2x Intel® I211AT
 - Speed: 10/100/1000 Mbps
- **Interface:** 2 x RJ45
- **Standard:** Compliant with IEEE 802.3az.

1.3 Chipset

1.3.1 Functional specification

1.3.1.1 Processor

Processor	Intel® Celeron® J1900 2.0GHz processor
-----------	--

1.3.1.2 Chipset

Memory	<ul style="list-style-type: none"> ■ Supports DDR3L 1333 MHz (without ECC) ■ SODIMM Socket <ul style="list-style-type: none"> – 260-pin SODIMM socket*2 (up to 8 GB)
Processor Graphics	<ul style="list-style-type: none"> ■ Intel® HD Graphics for Intel Atom® Processor Z3700 Series ■ IO interface <ul style="list-style-type: none"> – VGA: Supports resolutions up to 1920 x 1080 @ 60 Hz (VGA connector: On-board D-SUB 15P) – HDMI: Supports resolution up to 1920 x 1080 @ 60 Hz (HDMI Connector: On-board HDMI 19P)
SATA Interface	<ul style="list-style-type: none"> ■ 1x SATA Revision 3.0 ports 2.5" HDD/SSD ■ 1x NGFF M.2 M key, support 22x42 ■ Support OS storage and boot
USB Interface	<ul style="list-style-type: none"> ■ USB host interface for 3 x USB2.0 port /1 x USB3.0 port ■ Supports high-speed, full-speed, and low-speed capable ■ Supports legacy keyboard/mouse software
Power Management	<ul style="list-style-type: none"> ■ +10V~+36V DC Input Duel from 4pin plug connector ■ Power Connector: Plug-in block 4Px1
BIOS	<ul style="list-style-type: none"> ■ AMI 64Mb Flash BIOS via SPI

1.3.1.3 Others

Serial Ports	<p>4xUART on front panel</p> <p>COM1/2: Support to RS-232/422/485 and setting mode by BIOS and supports auto flow control (The data rate of each serial port up to 115.2k)</p> <p>COM 3/4: Support to RS-232 (The data rate of each serial port up to 115.2k)</p> <p>Serial ports connector: D-SUB CON.9P</p>
LAN	<p>LAN1: Intel® i211AT; LAN2: Intel® i211AT</p> <ul style="list-style-type: none"> ■ Compliant with IEEE 802.3az. ■ Supports 10/100/1000 Mbps ■ Supports Wake on LAN
Audio	<p>Audio Codec: Realtek ALC888:</p> <ul style="list-style-type: none"> ■ Compliant with HD Audio specifications ■ Supports to 16/20/24-bit DAC and 16/20/24-bit ADC resolution ■ 1x audio Line-out phone jack on front panel
Battery backup	<ul style="list-style-type: none"> ■ BR2032 3V/190mAh

1.4 Mechanical Specifications

1.4.1 Dimensions

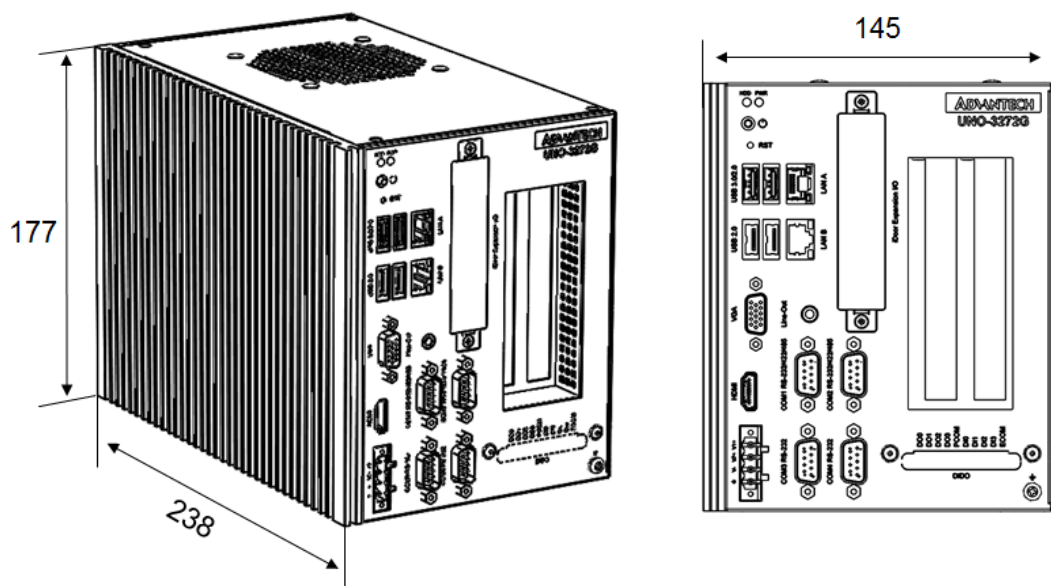

Figure 1.1 Dimensions

1.4.2 Weight

2.6 kg

1.5 Power Requirements

1.5.1 System power

DC 10-36V_{DC}

1.5.2 RTC battery

BR2032 3 V/190 mAh

1.6 Environment Specification

1.6.1 Operating temperature

-20 ~ 60 °C with 0.7m/sec air flow: with 1x Industrial SSD without PCI/PCIe expansion boards

1.6.2 System safety certification test temperature

0 ~ 40 °C with 2.5" HDD

1.6.3 Relative humidity

95% @ 40 °C (non-condensing)

1.6.4 Storage temperature

-40 ~ 85 °C (-40 ~ 185 °F)

1.6.5 Vibration during operation

- When system is equipped with SSD only: 2 Grms, IEC 60068-2-64, random, 5 ~ 500 Hz, 1 Oct/min., 1 hr/axis, x,y,z 3 axes.
- When system is equipped with 2.5-inch HDD: 0.5 Grms, IEC 60068-2-64, random, 5 ~ 500 Hz, 1 Oct/min., 1 hr/axis, x,y,z 3 axes.

1.6.6 Shock during operation

When system is equipped with SSD only: 30 G, IEC 60068-2-27, half sine, 11 ms duration.

1.6.7 Safety

UL/CB, CCC, BSMI

1.6.8 EMC

CE, FCC, CCC, BSMI

Chapter 2

H/W Installation

This chapter introduces external IO and the installation of UNO-3272G hardware.

2.1 Introduction

The following sections show the internal jumper settings and the external connectors and pin assignments.

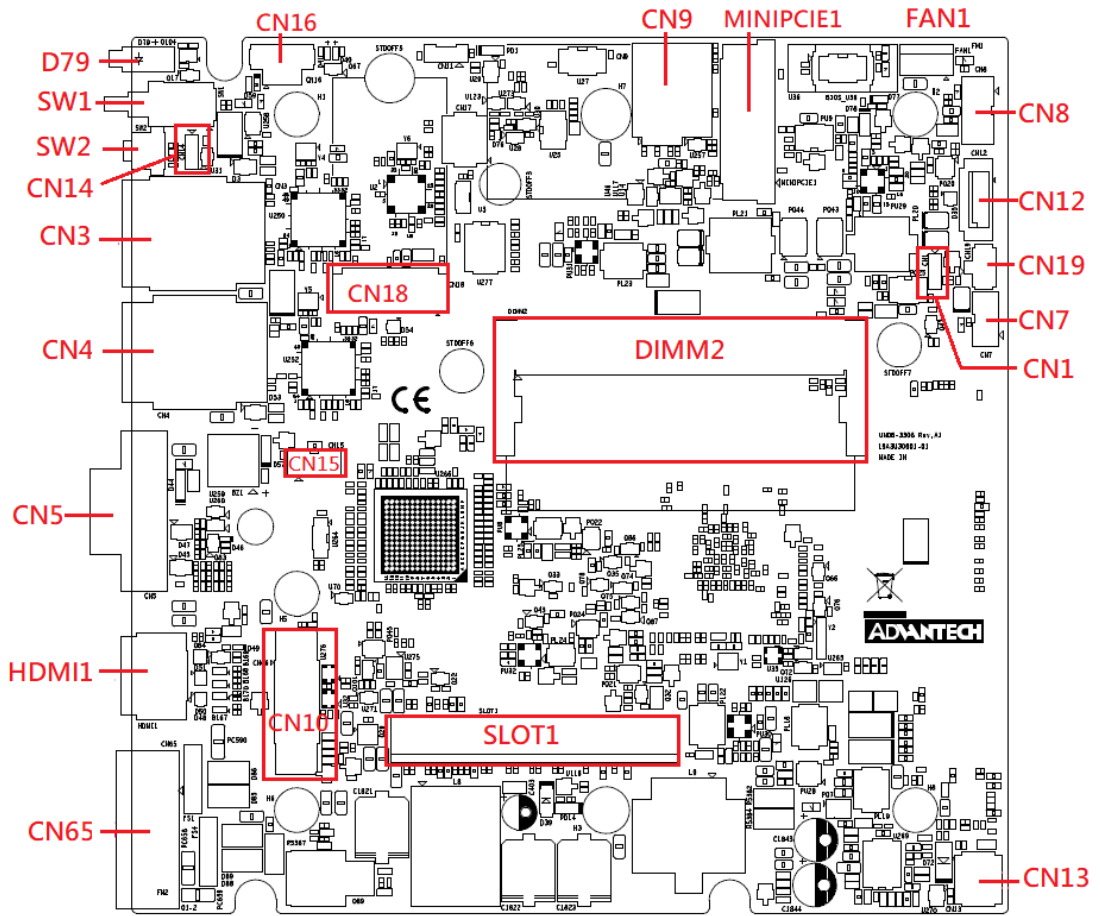

Figure 2.1 Motherboard Connector and jumper locations (top side)

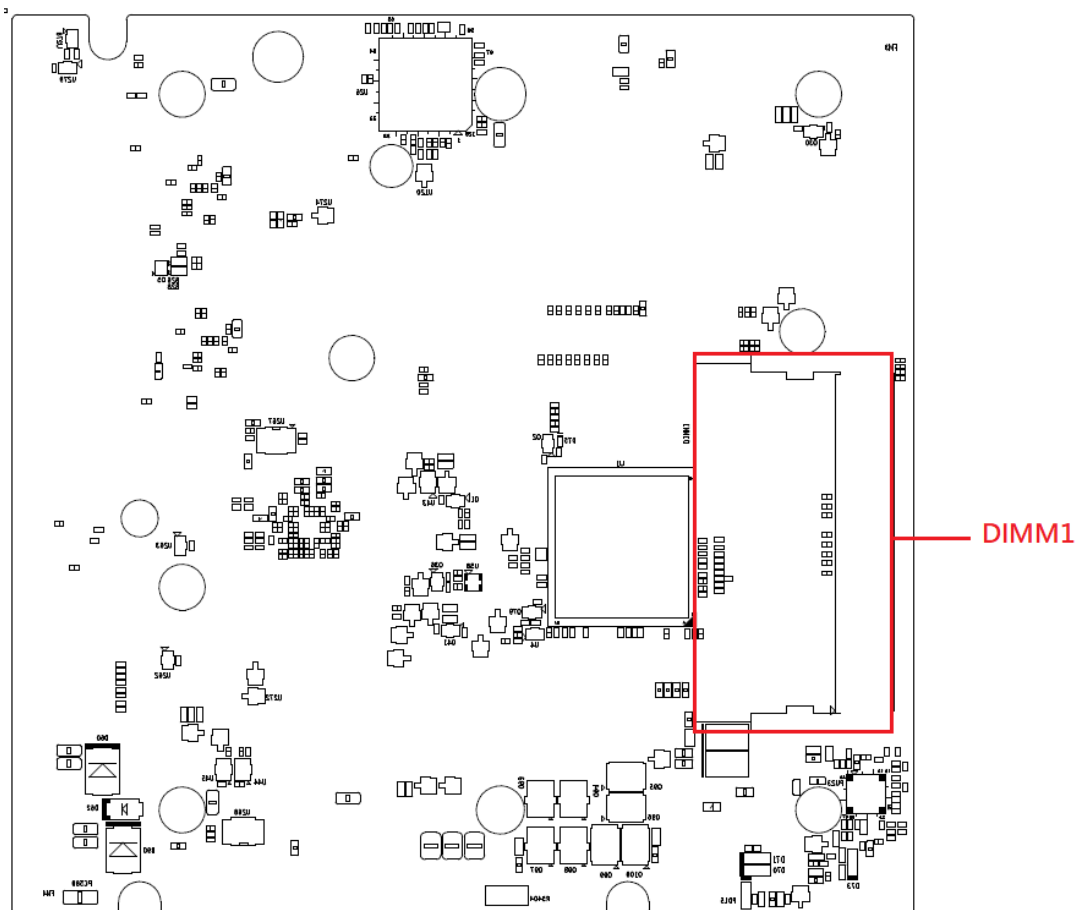

Figure 2.2 Motherboard Connector and jumper locations (rear side)

Table 2.1: Motherboard Connector

Location	Function	Location	Function
CN3	LANA+USB3.0/2.0	CN16	Internal Power Switch/Reset
CN4	LANB+USB2.0	CN18	M.2
CN5	VGA	CN65	Power Input
CN7	Internal USB2.0	MPCIE1	Mini PCIe
CN8	SATA Power	SLOT1	PCIe Slot
CN9	SIM Holder	D79	Power/SATA status LED
CN10	COM1/2/3/4+Audio	SW1	Power Switch
CN12	SATA	SW2	Reset
CN13	DIDO	DIMM1	DDR Slot1
CN15	Inverter Power	DIMM2	DDR Slot2

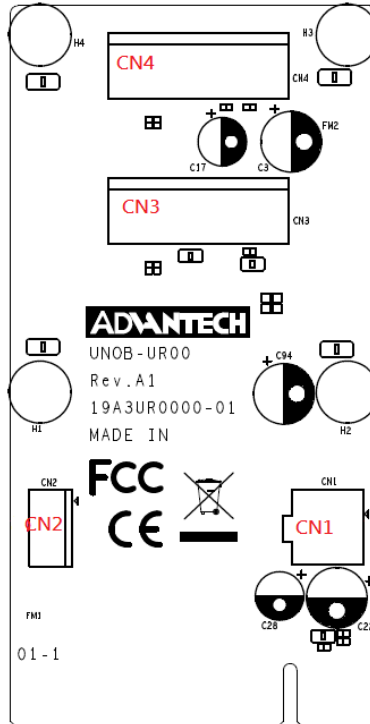

Figure 2.3 PCIe card connector locations

Table 2.2: PCIe Connector

Location	Function
CN1	12V Power Output
CN2	5V&12V Power Output
CN3	PCIe2
CN4	PCIe1

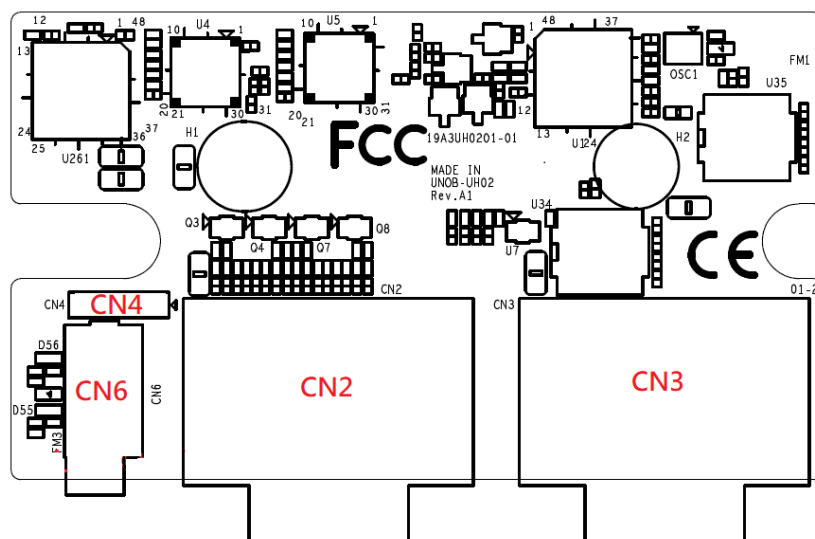

Figure 2.4 COM card connector locations

Table 2.3: COM Connector

Location	Function
CN2	COM1/COM2
CN3	COM3/COM4
CN4	MIC IN
CN6	LINE Out

2.2 Jumpers

Configure the UNO-3272G to match the needs of your application by setting jumpers. To close a jumper, you connect the pins with the clip. To open a jumper, you remove the clip. Sometimes a jumper will have three pins, labeled 1, 2 and 3. In this case you would connect either pins 1 and 2, or 2 and 3.

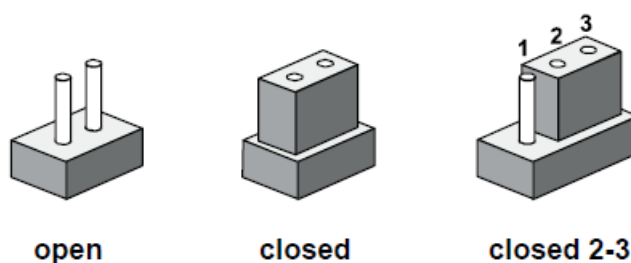

The jumper settings are schematically depicted in this manual as follows.

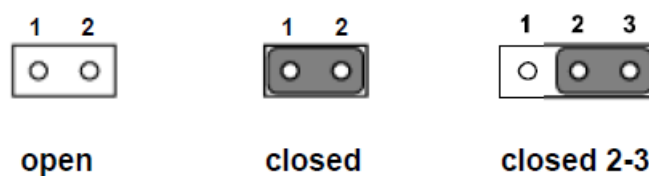

A pair of needle-nose pliers may be helpful when working with jumpers. If you have any doubts about the best hardware configuration for your application, contact your local distributor or sales representative before you make any changes. Generally, you simply need a standard cable to make most connections.

2.2.1 Jumper list

Table 2.4: Jumper List (motherboard)

Location	Function
CN1	Clear CMOS
CN14	System AT/ATX mode option

2.2.1.1 Clear CMOS

UNO-3272G mainboard contains a jumper that can erase CMOS data and reset the system BIOS information. Normally this jumper should be set with pins 1-2 closed. If you want to reset the CMOS data, set CMOS1 to 2-3 closed for just a few seconds, and then move the jumper back to 1-2 closed. This procedure will reset the CMOS to its default setting.

CMOS1	Clear CMOS
Footprint	3x1 Pin
Setting Function	Function
(1-2)	Normal (default)
(2-3)	Clear CMOS

2.2.1.2 System AT/ATX mode function option

UNO-3272G supports AT or ATX mode and default is ATX module. If you want to change to AT mode you can find AT/ATX mode jumper on the motherboard.

PSON1	System AT/ATX mode option
FootPrint	3x1 Pin
Setting Function	Function
(1-2)	AT mode
(2-3)	ATX mode

2.3 Connectors

2.3.1 External I/O Connectors

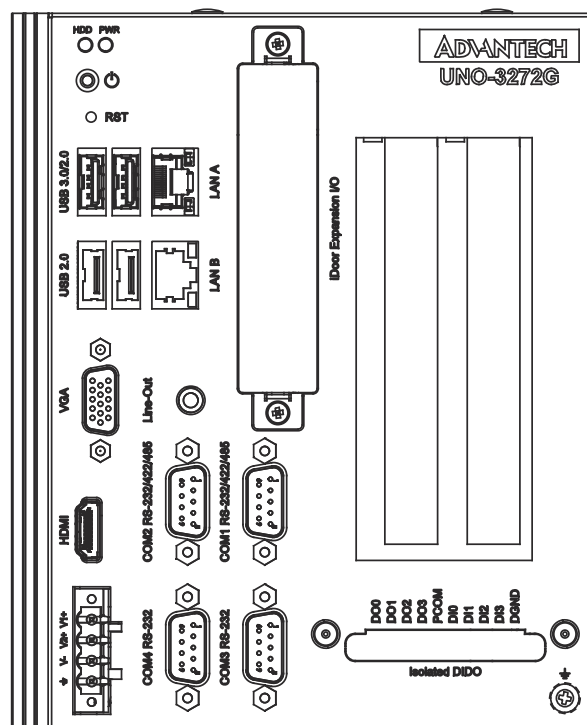

Figure 2.5 UNO-3272G Front View

2.3.1.1 COM connector

UNO-3272G provides four 9-pin D-sub connectors, two of which offer RS-232/422/485 and the other two offer RS-232 serial communication interface ports. Default setting is RS-232, but this can be modified by BIOS setting. You can find detailed setting methods in Chapter 3.

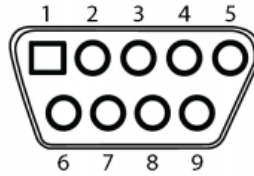

Figure 2.6 COM Connector

Table 2.5: COM Connector Pin Assignments

	RS-232	RS-422	RS-485
Pin	Signal Name	Signal Name	Signal Name
1	DCD	TX-	DATA-
2	RXD	TX+	DATA+
3	TXD	RX+	-
4	DTR	RX-	-
5	GND	GND	GND
6	DSR	-	-
7	RTS	-	-
8	CTS	-	-
9	RI	-	-

Note! NC represents "No Connection".



2.3.1.2 Ethernet connector (LAN)

UNO-3272G is equipped with two Ethernet controllers that are fully compliant with IEEE 802.3u 10/100/1000 Mbps CSMA/CD standards. LANA & LANB are equipped with Intel i211. The Ethernet port provides a standard RJ45 jack connector with LED indicators on the front side to show its Active/Link status and Speed status.

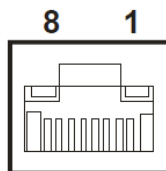

Figure 2.7 LAN Connector

Table 2.6: Ethernet Connector Pin Assignments

Pin	Signal Name	Description
1	MDI0+	<ul style="list-style-type: none"> In BASE-T: Media Dependent Interface[0]: 1000BASE-T: In MDI configuration, MDI[0]+/- corresponds to BI_DA+/- and in MDI-X configuration MDI[0]+/- corresponds to BI_DB+/-.
2	MDI0-	<ul style="list-style-type: none"> 10BASE-T and 100BASE-TX: In MDI configuration, MDI[0]+/- is used for the transmit pair and in MDIX configuration MDI[0]+/- is used for the receive pair.
3	MDI1+	<ul style="list-style-type: none"> In BASE-T: Media Dependent Interface[1]: 1000BASE-T: In MDI configuration, MDI[1]+/- corresponds to BI_DB+/- and in MDI-X configuration MDI[1]+/- corresponds to BI_DA+/-.
6	MDI1-	<ul style="list-style-type: none"> 10BASE-T and 100BASE-TX: In MDI configuration, MDI[1]+/- is used for the receive pair and in MDI-X configuration MDI[1]+/- is used for the transmit pair.
4	MDI2+	<ul style="list-style-type: none"> In BASE-T: Media Dependent Interface[3:2]: 1000BASE-T: In MDI and in MDI-X configuration, MDI[2]+/- corresponds to BI_DC+/- and MDI[3]+/- corresponds to BI_DD+/-.
5	MDI2-	
7	MDI3+	
8	MDI3-	<ul style="list-style-type: none"> 100BASE-TX: Unused. 10BASE-T: Unused.

Table 2.7: LED Indicators

Left LED		Right LED	
10 Link	100 Left	1000 Link	Active
Off	Orange	Green	Green

2.3.1.3 Audio connector

UNO-3272G has only one stereo audio ports with phone jack connectors- Line_Out. The audio chip is controlled by ACL888-VD2, and it's compliant with AZALIA standard.



Figure 2.8 Audio Connector

Table 2.8: Audio Connector Pin Assignments

Pin	Audio signal Name
1	Line_out

2.3.1.4 USB 3.0 connector

UNO-3272G provides one USB 3.0 & three USB2.0 interface connectors, which give complete Plug & Play and hot swapping for up to 127 external devices. The USB interface complies with USB XHCI, Rev. 3.0. Please refer to the table below for pin assignments.

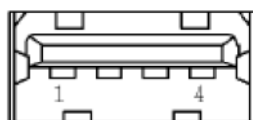

Figure 2.9 USB 2.0 Connector

Table 2.9: USB 2.0 connector Pin Assignments

1	VCC
2	DATA-
3	DATA+
4	GND

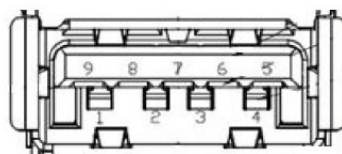

Figure 2.10 USB 3.0 Connector

Table 2.10: USB 3.0 connector Pin Assignments

1	VCC
2	USB Data -
3	USB Data +
4	GND
5	SSRX-
6	SSRX+
7	GND
8	SSTX-
9	SSTX+

2.3.1.5 VGA connector

The UNO-3272G provides a high resolution VGA interface with a 15-pin D-sub connector to support a VGA CRT monitor. It supports display resolution of up to 1920 x 1080 @ 60 Hz.

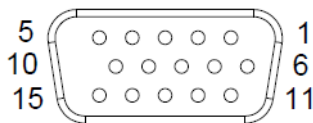

Figure 2.11 VGA Connector

Table 2.11: VGA Connector Pin Assignments

Pin	Signal Name	Pin	Signal Name
1	Red	2	Green
3	Blue	4	NC
5	GND	6	GND
7	GND	8	GND
9	+5V	10	GND
11	NC	12	DDC_DAT
13	H-SYNC	14	V-SYNC
15	DDC_CLK		

2.3.1.6 HDMI Connector

UNO-3272G provides a high resolution HDMI, It supports display resolution of up to 1920 x 1080 @ 60 Hz.

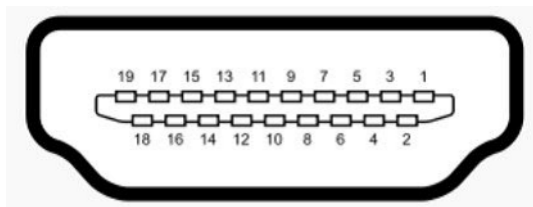

Figure 2.12 HDMI Connector

Table 2.12: HDMI Connector Pin Assignments

Pin	Signal Name	Pin	Signal Name
1	TMDS Data2+	2	TMDS Data2 Shield
3	TMDS Data2-	4	TMDS Data1+
5	TMDS Data1 Shield	6	TMND Data1-
7	TMDS Data0+	8	TMDS Data0 Shield
9	TMDS Data0-	10	TMDS Clock+
11	TMDS Clock Shield	12	TMDS Clock-
13	NL	14	Reserved
15	SCL	16	SDA
17	DDC/CEC/HEC Gound	18	+5V Power (max 50mA)
19	Hot Plug Detect		

2.3.1.7 Power Input Connector

UNO-3272G comes with a four-pin header as default that carries 10VDC - 36VDC external dual power input. This product is intended to be supplied by a UL Listed DC Power Source, rated 10-36Vdc, 6.5-1.8A and Tma 40 degree C, if need further assistance, please contact Advantech for further information (Ensure to connect the power cord to a socket-outlet with earthing connection).

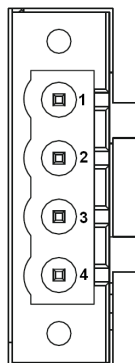

Figure 2.13 Power Connector

Table 2.13: Pin Assignments for Power Connector Pin Header

Pin	Signal Name
1	+VDC1
2	+VDC2
3	GND (Power GND)
4	Chassis GND

2.3.1.8 Power ON/OFF button & LED indicators

UNO-3272G comes with a Power On/ Off button with LED indicators on the front side to show its On status (Green LED) and Off/Suspend status (Yellow LED), that supports dual function of Soft Power-On/Off and suspend.

2.3.1.9 Digital power input/ output (Optional)

UNO-3272G provide optional DI/O functions by ordering additional P/N: UNO-3000-DIOAE.

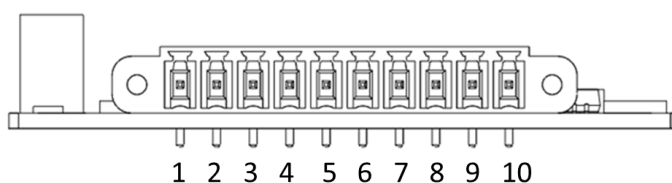

Table 2.14: DI/ DO Pin Assignments

Pin	Signal Name	Description
1	DO0	Isolated digital output
2	DO1	Isolated digital output
3	DO2	Isolated digital output
4	DO3	Isolated digital output
5	PCOM	Freewheeling common diode for IDO

Table 2.14: DI/ DO Pin Assignments

6	DI0	Isolated digital input
7	DI1	Isolated digital input
8	DI2	Isolated digital input
9	DI3	Isolated digital input
10	DGND	External common of IDI0~3

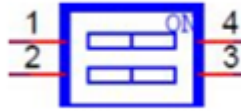

Table 2.15: DI/DO switch

	Dry Contact	Wet Contact
1	OFF	ON
2	ON	OFF

Default: Dry contact

Isolated Digital Input Each of the 4 isolated digital input channels accept voltages from 0 to 30 V. Every four input channels share one external common. (Pin1-4 use PCOM and DGND, Pin 6-9 use DGND) The following figure shows how to connect an external input source to the card's isolated inputs.

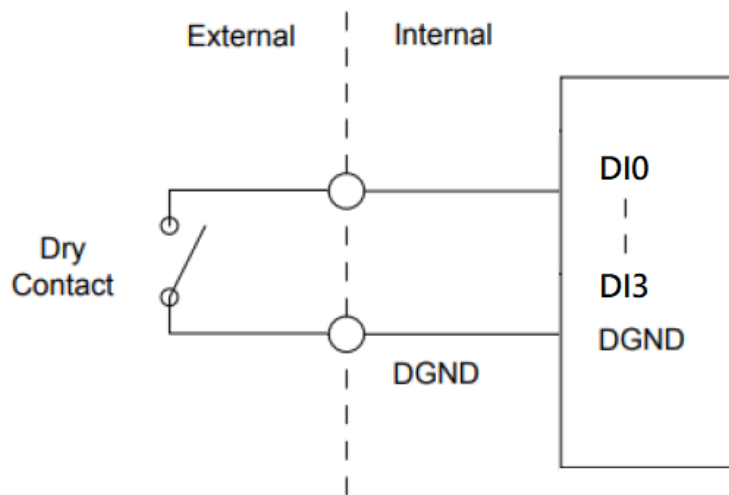

Figure 2.14 Isolated DI Dry connection

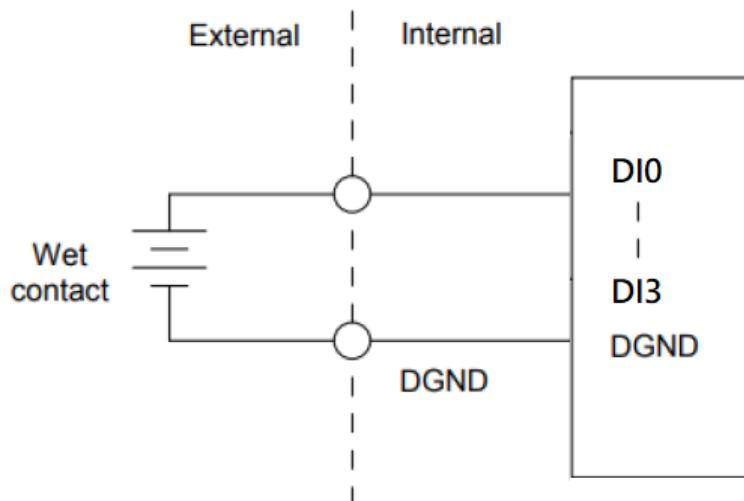

Figure 2.15 Isolated DI Wet connection

Isolated Digital Output If the external voltage source (5~40 V) is connected to each isolated output channel (IDO) and its isolated digital output turns on (200 mA max./ch), the card's current will sink from the external voltage source. The following figure shows how to connect an external output load to the card's isolated outputs.

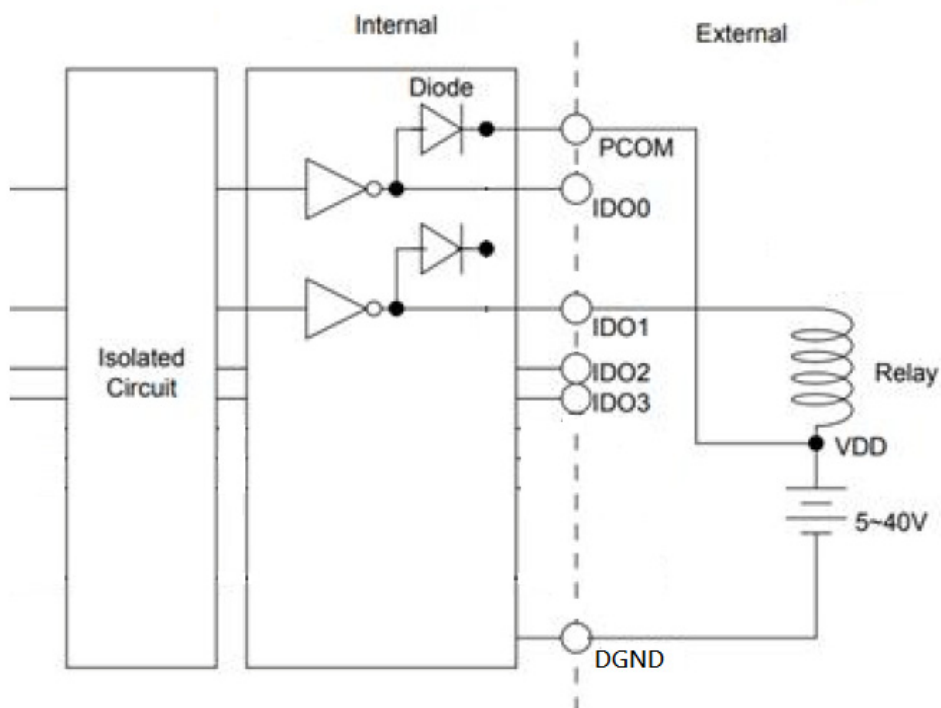

Figure 2.16 Isolated Digital Output Connection

2.3.2 Internal I/O Connectors

Table 2.16: PCIe Connector Pin Assignments

	CN1	CN2	FAN1
Pin	Signal Name	Signal Name	Signal Name
1	GND	+V12	+V12
2	GND	GND	GND
3	+V12	GND	NC
4	+V12	+5V	

2.4 Installation

2.4.1 HDD installation

UNO-3272G supports 1 HDD/ SDD installation. The following steps demonstrate how to install 2.5" storage.

1. Remove 8 screws from top and side cover of UNO

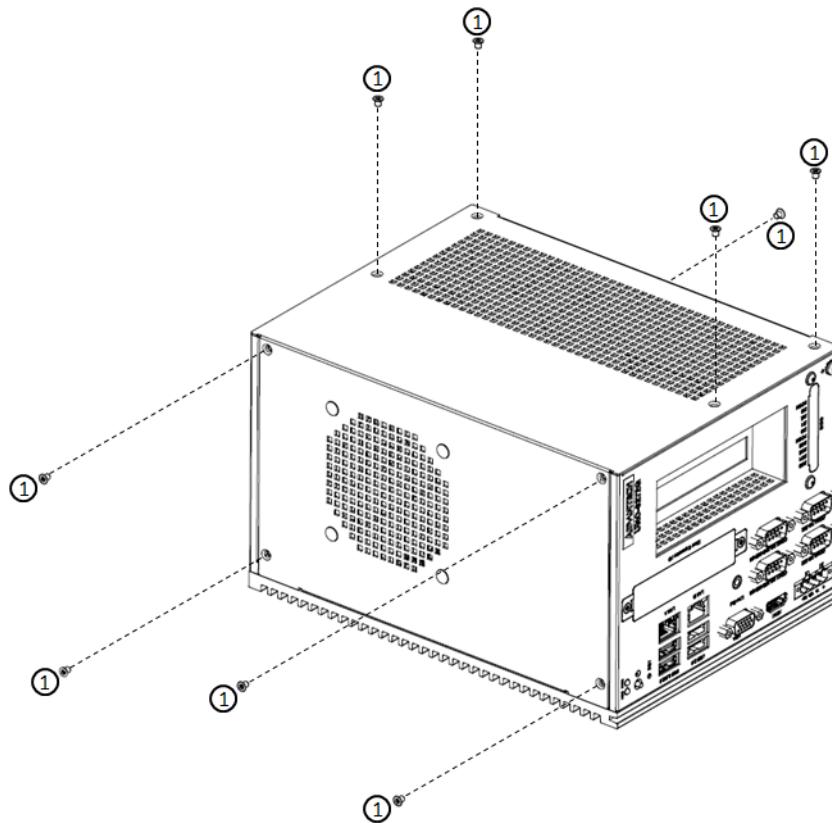

2. Remove the 4 screws on rear cover of UNO.

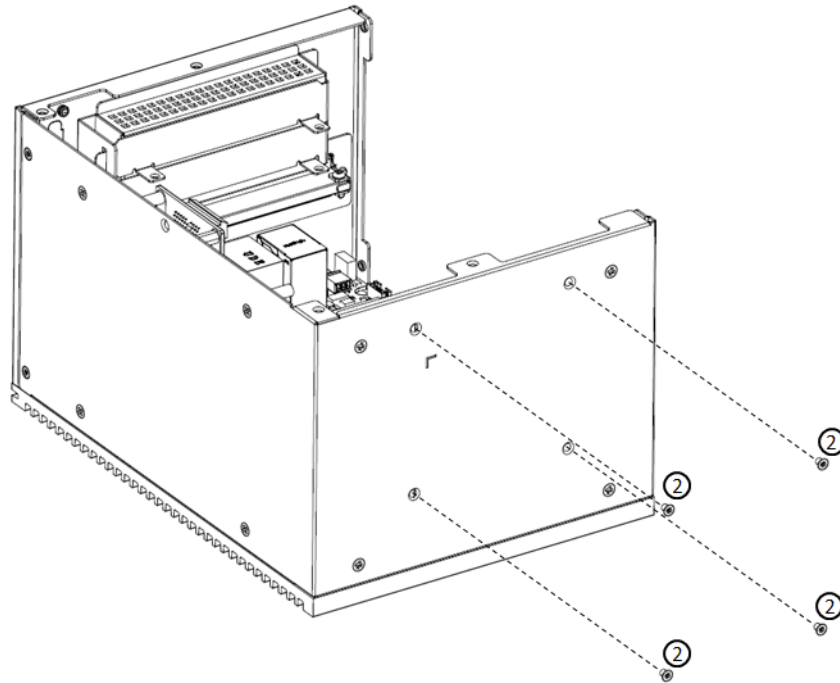

3. Take off the HDD/SSD tray from rear cover inside.

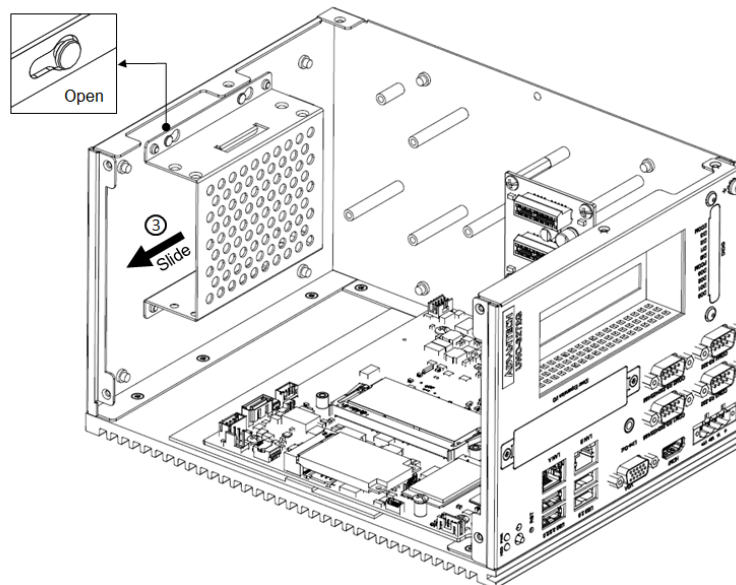

- Secure the HDD with 4 pcs reserved screws in the accessory package.

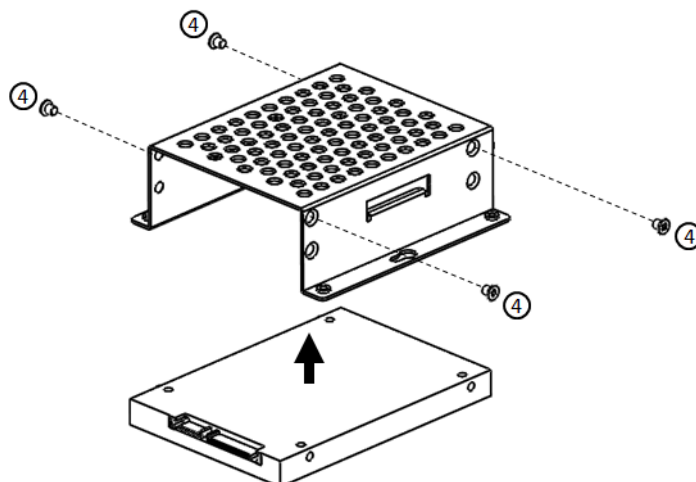

- Slide down the tray and replace all the screws and put the cover back.

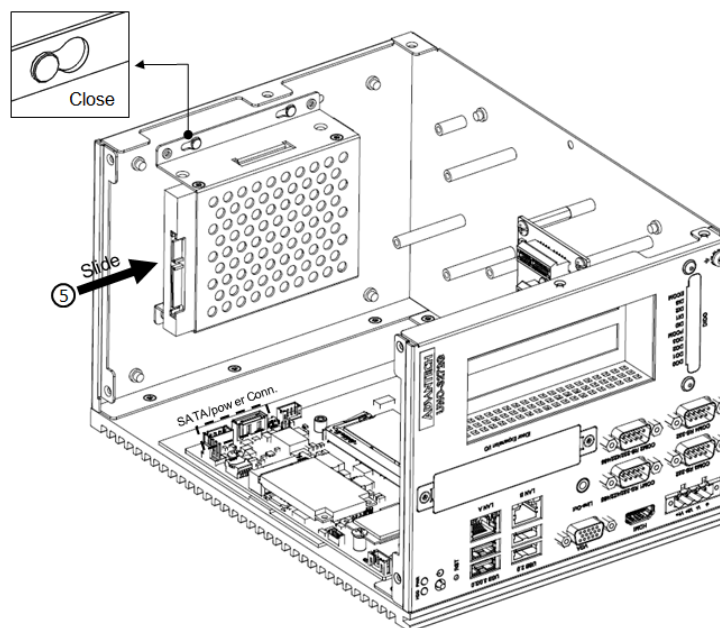

2.4.2 Memory & M.2 storage installation

UNO-3272G has default build-in 4G RAM, but can support up to 8GB by adding additional 4G Memory; UNO-3272G also provides M.2 B-key storage with up to 512 GB. Following steps demonstrate how to install additional RAM and M.2 Storage.

1. Remove the 8 screws from the top and side cover of UNO, install the RAM module and M.2 storage as below:

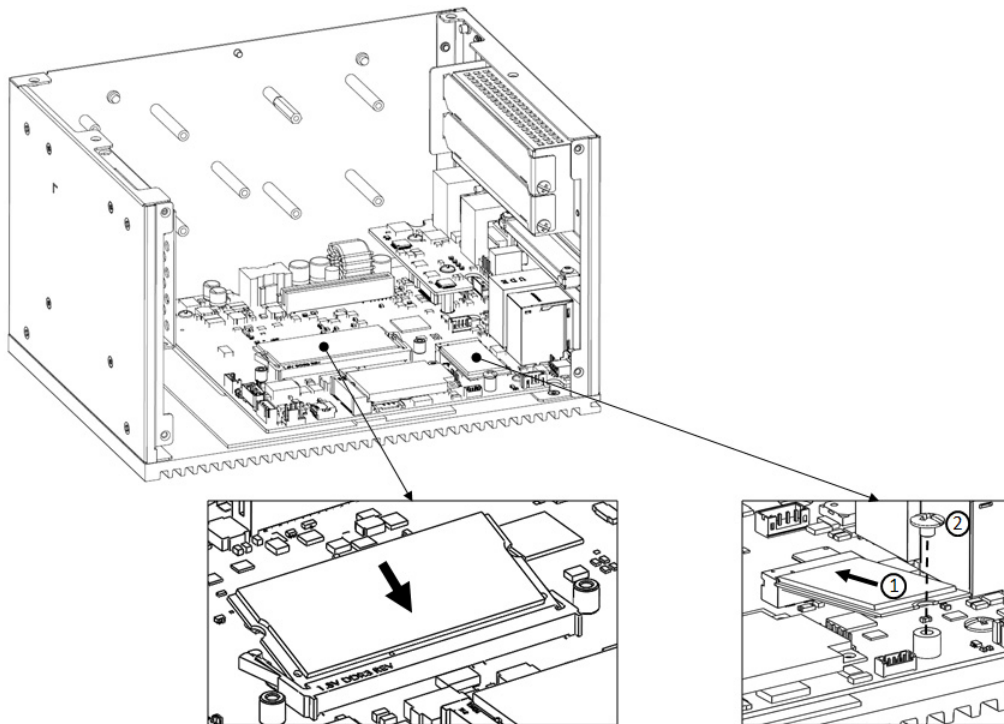

2. Replace all screws and put the cover back.

2.4.3 iDOOR Installation

UNO-3272G supports 1 x iDOOR expansion by utilizing the mPCIe interface. The following steps demonstrate how to install the iDOOR module with the mPCIe card.

1. Remove 8 screws from top and side cover of UNO, install the mPCIe module as below:

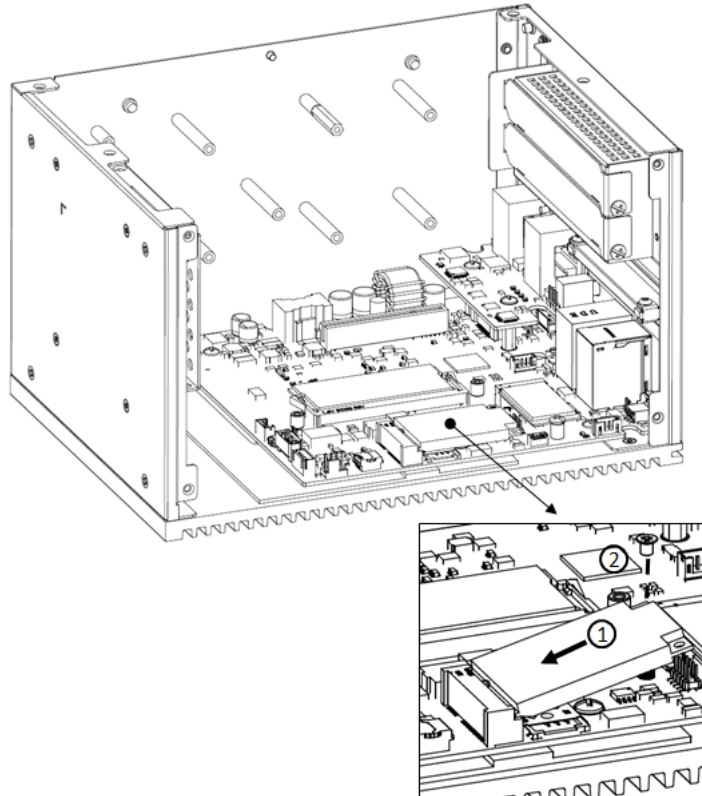

2. Remove iDOOR screws on front panel and take off the iDOOR plate from UNO.

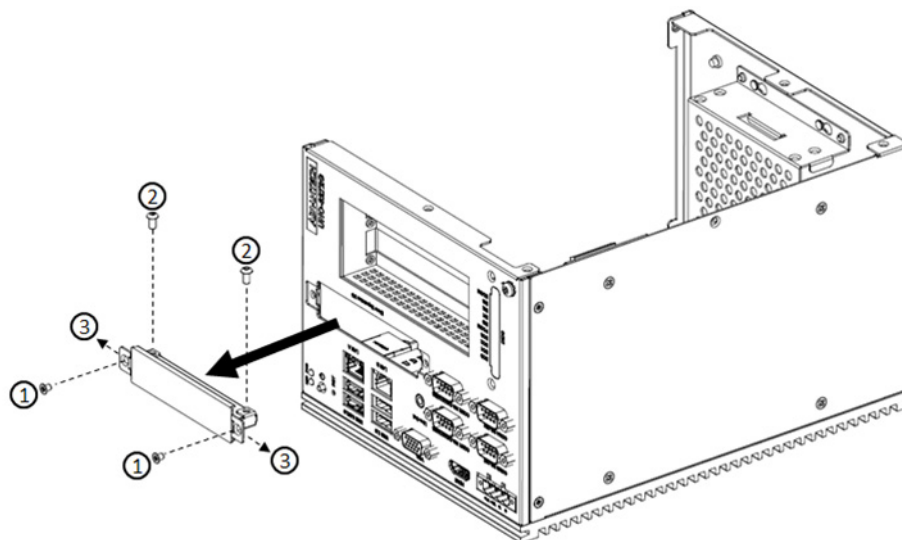

3. Remove the iDOOR plate and attach the iDOOR module you selected.
4. Screw back the iDOOR module back on UNO.

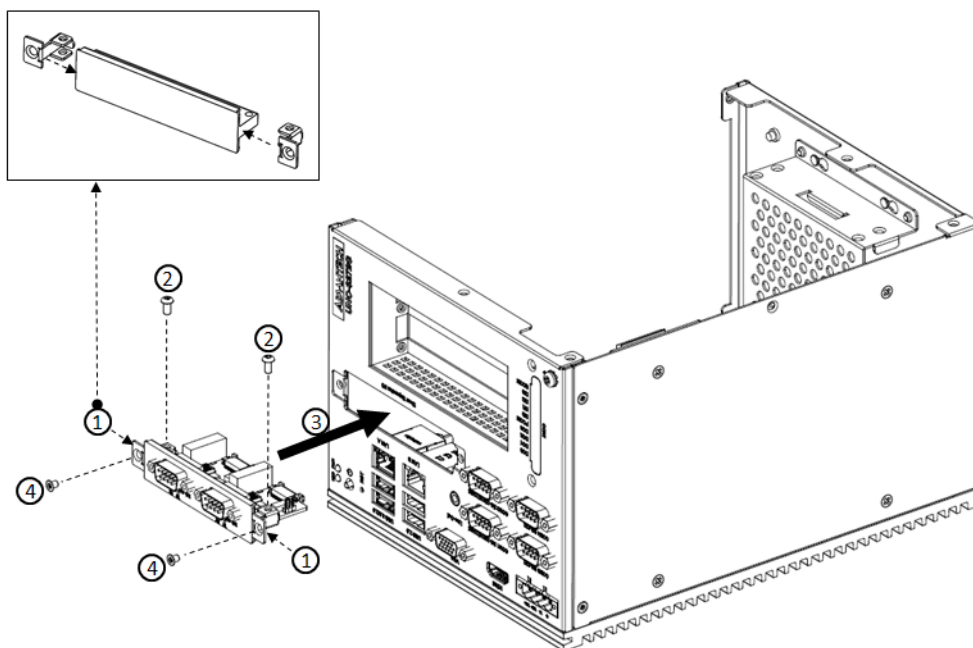

2.4.4 DIO card Installation (Optional)

UNO-3272G allows 4 x DI/DO by ordering additional DIO cards (PN: UNO-3000-DIOAE). Follow these steps to demonstrate how to install a DI/O card.

1. Remove the rubber and punch out from the reserved DI/O holes.

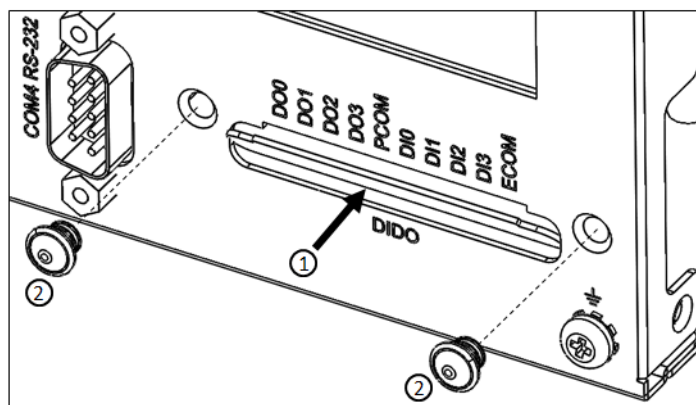

2. Fix the DI/O card by replacing the 2 screws on accessory package.

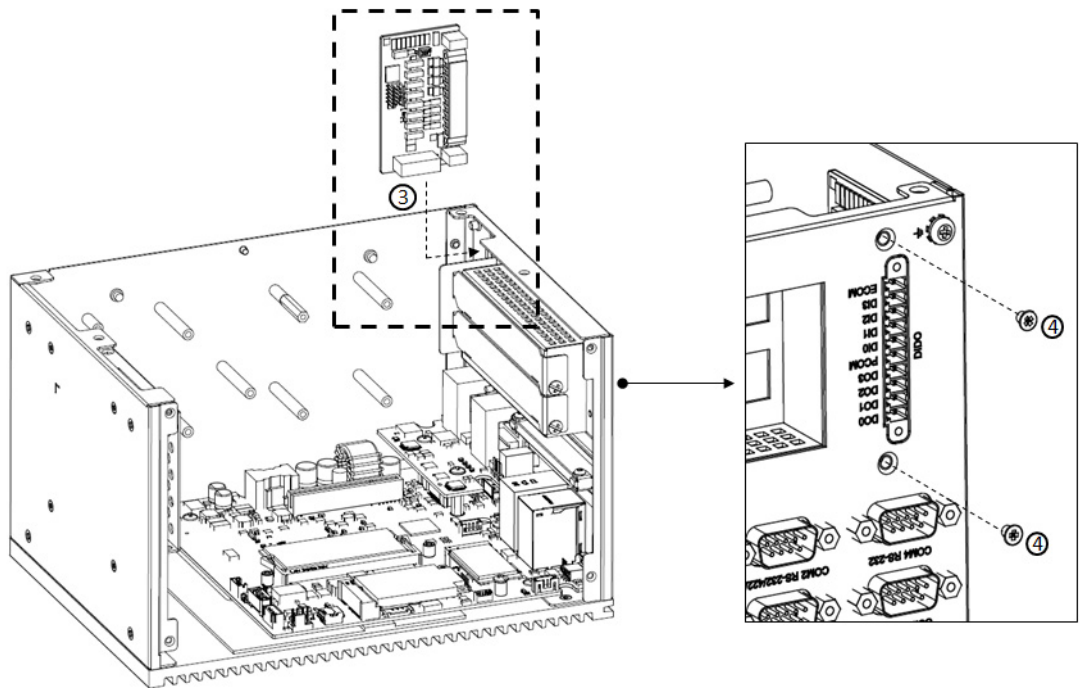

3. Connect DI/O cable as below (Motherboard: CN13).

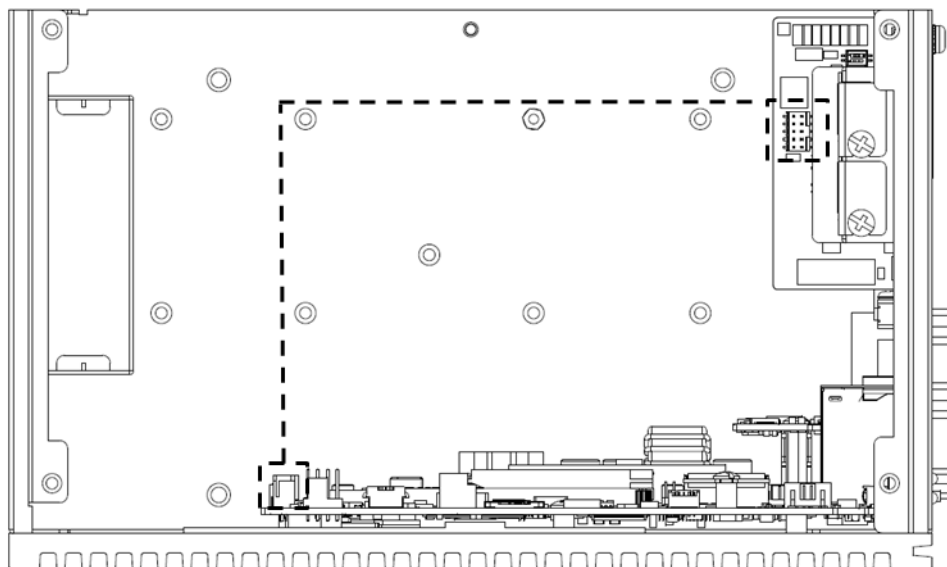

2.4.5 PCI/ PCIe Installation (Optional)

UNO-3272G provides 2 x PCIe x1 expansion slots for add-on cards. Follow the steps for how to install add-on cards.

1. Remove 8 screws from the top and side cover of UNO as well as the PCI/PCIe bracket.

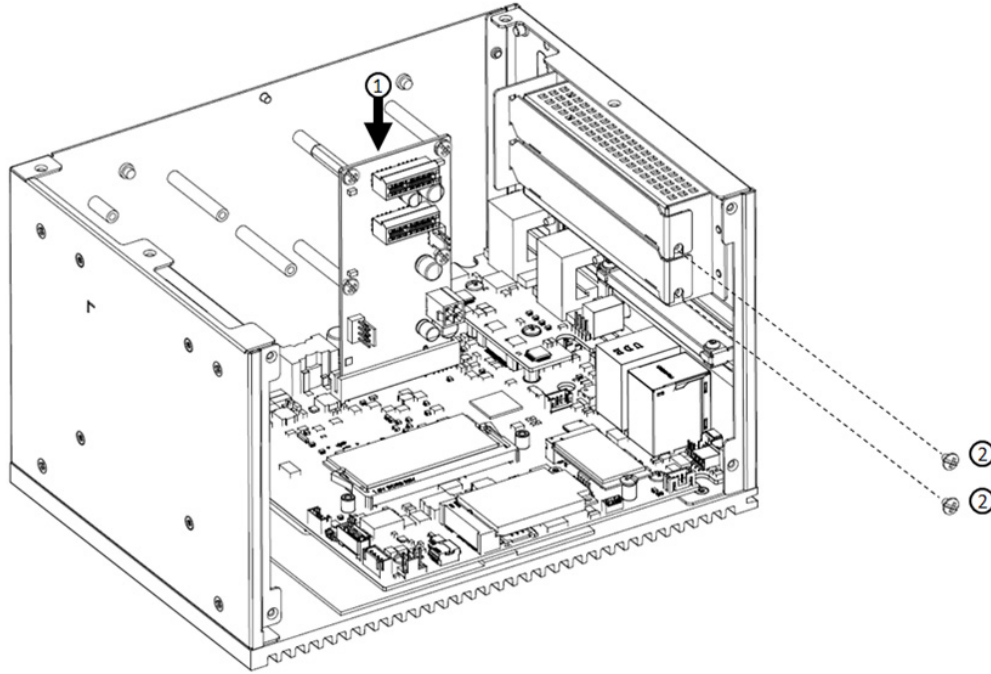

2. Plug in add-on card as below and fix the card by replacing the screws.

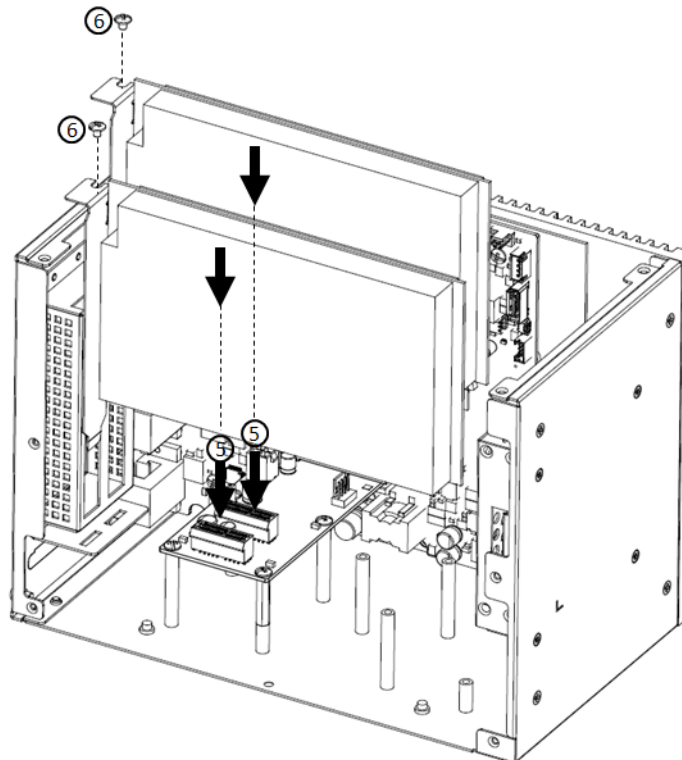

2.4.6 FAN-kit Installation (Optional)

The following steps demonstrate how to install an optional fan kit (PN: UNO-3000-FANAE)

1. Remove 8 screws from the top and side cover of UNO and take out the filter.

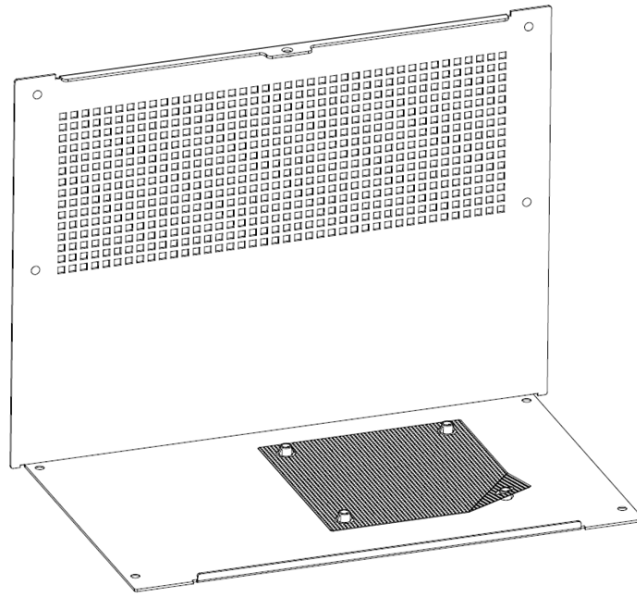

2. Remove 4 screws on the top cover.

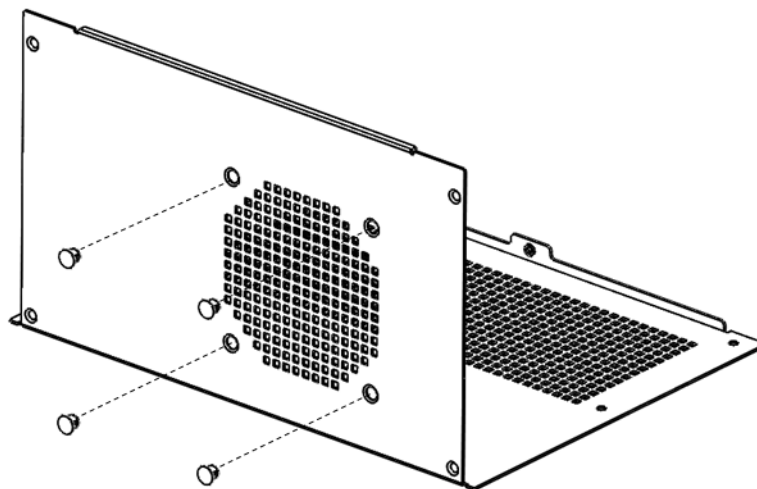

3. Fix the fan-kit by replacing the 4 screws.

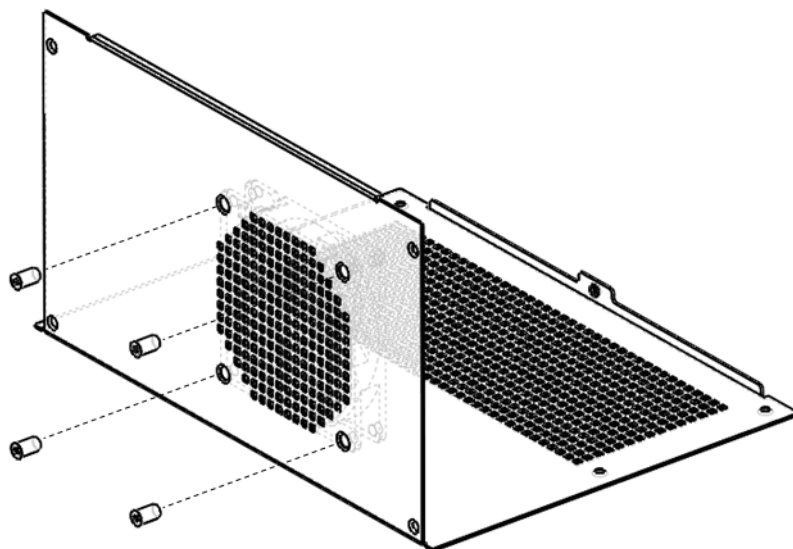

4. Connect power cable as below.

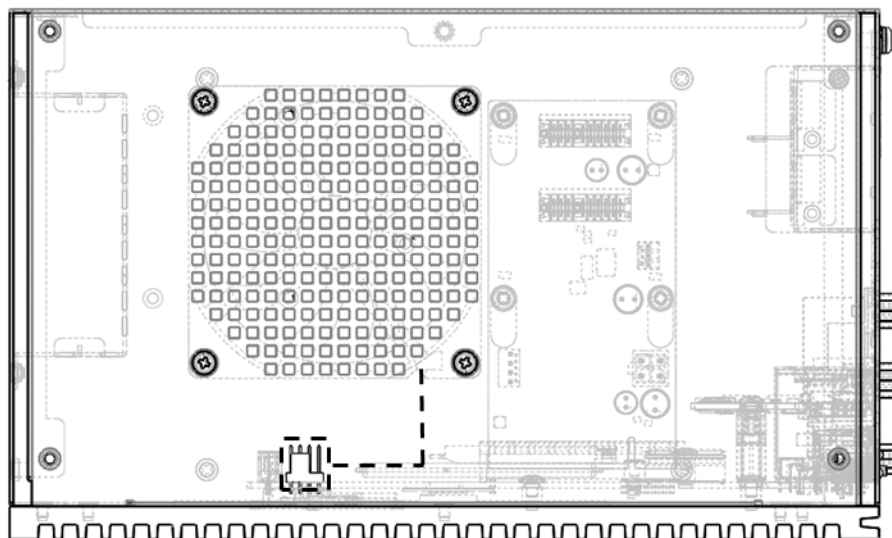

2.4.7 Riser card (change) Installation

UNO-3272G provides other riser cards (2 x PCI) for different applications.

1. Pull out the current riser card and remove the copper pillars from the chassis.

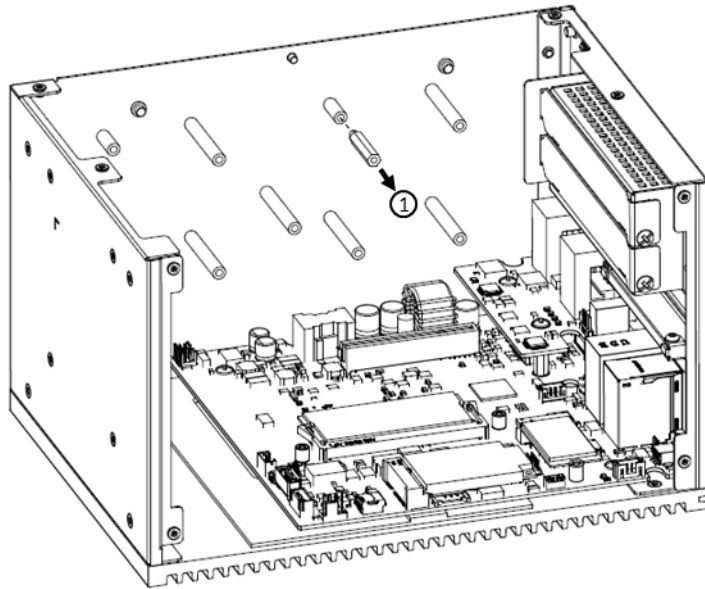

2. Plug in the new riser card then replace the 5 screws.

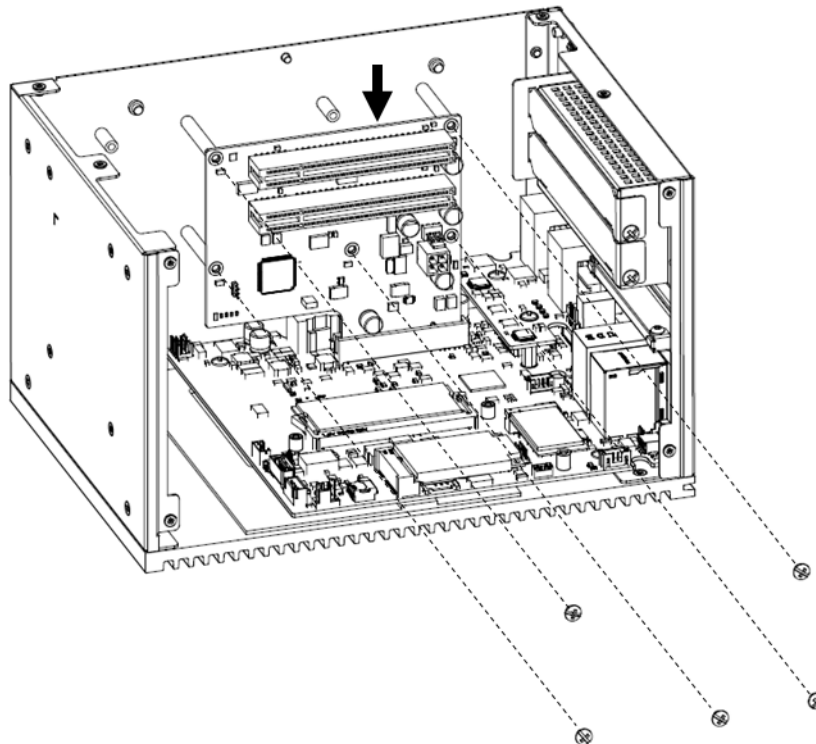

2.4.8 Mounting kit Installation (Optional)

UNO-3272G supports wall mount and stand mount. Optional mounts (PN:UNO-3000-WMKAE).

2.4.8.1 Wall Mounting

1. Remove the screws from UNO chassis then fix the mounting kit on UNO using the same screws (M4*5L*4 Pcs).

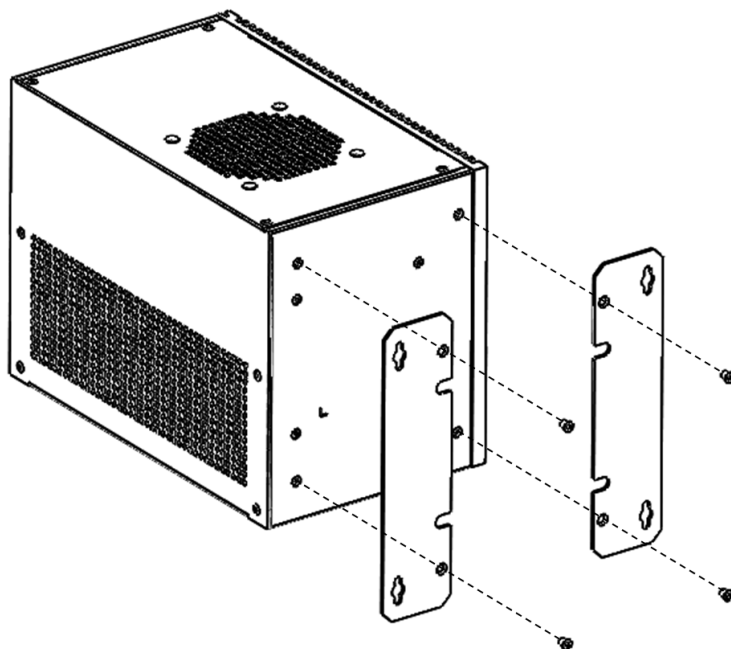

2. Install UNO-3272G on the wall by replacing the 4 screws.

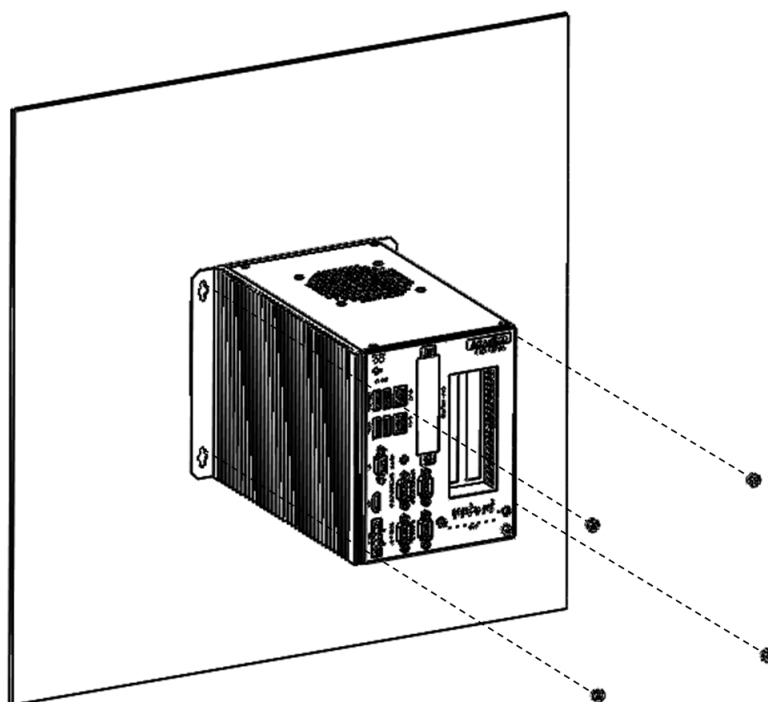

2.4.8.2 Stand Mounting

1. Remove the screws from the UNO chassis then fix the mounting kit on UNO using same screws.

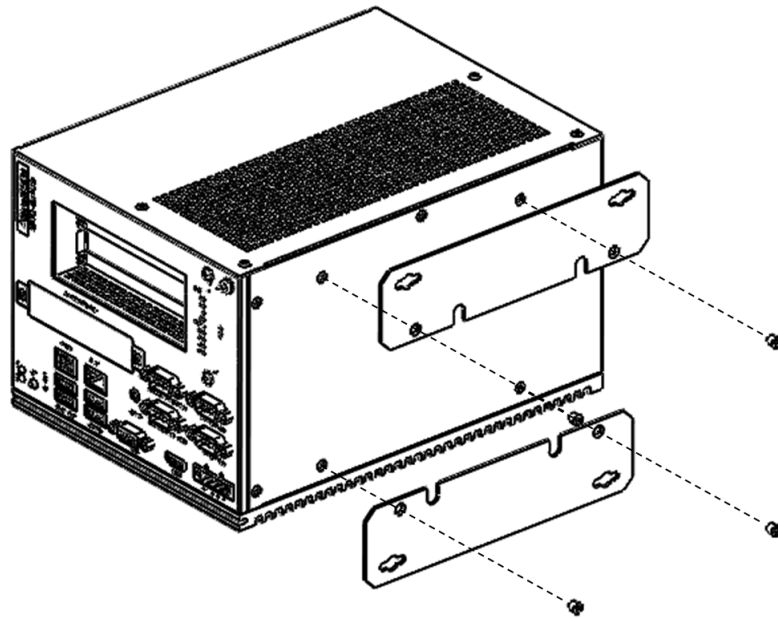

2. Install UNO-3272G by replacing the 4 screws

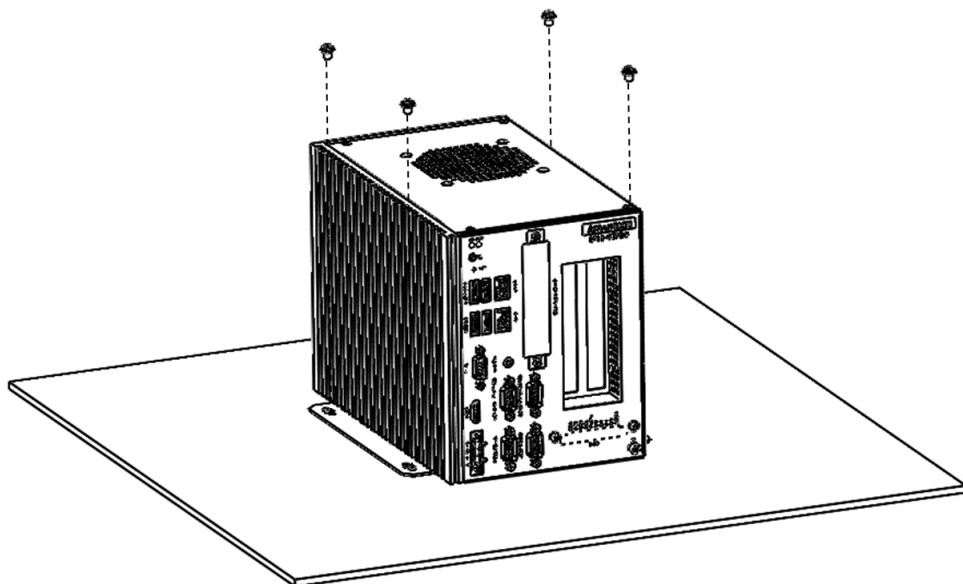

www.advantech.com

Please verify specifications before quoting. This guide is intended for reference purposes only.

All product specifications are subject to change without notice.

No part of this publication may be reproduced in any form or by any means, electronic, photocopying, recording or otherwise, without prior written permission of the publisher.

All brand and product names are trademarks or registered trademarks of their respective companies.

© Advantech Co., Ltd. 2019