

Advantech AE Technical Share Document

Date	2021/9/1	Related Product	AMAX-4K series	
Category	■ FAQ □ SOP			
Abstract	IAG_FAQ_ AMAX-4K series_ How to avoid external interference factors when occurring communication error, disconnect, or trigger fault.			
Keyword	AMAX-4K 、 communication error 、 disconnect 、 Grounding			
SR#	1-4658019971			
Revision History				
Date	Version	Author	Reviewer	Description
2021 / 9 / 1	V1.0	Adam.Chen	Owen.Chang	

■ **Problem Description:**

This FAQ explains how to avoid external interference factors when communication error 、 drop-out or trigger fault occurring in the AMAX-4K series.

- The physical is interrupted or the network topology has changed, and the Ethernet Frame has not reached all network slaves or has not returned to the master (such as cable broke, RJ-45 interface not connect, restart the slave during operation, etc...).
- The data frame reaches all the slave stations, but the correct bit sequence is destroyed (such as EMC interference, wrong equipment, etc...).
- The AMAX module needs to be wired grounded so that it avoids noise.

■ **Solution:**

About system architecture, users have to inspect few items below:

1. Don't place AMAX module around devices like inverter, motor, voltage transformer, etc.
2. For environments full of EMI/RFI, Shielded Twisted Pair, STP or Shielded Foil Twisted Pair connects the master station and slave station equipment to reduce interference between high-speed signals.

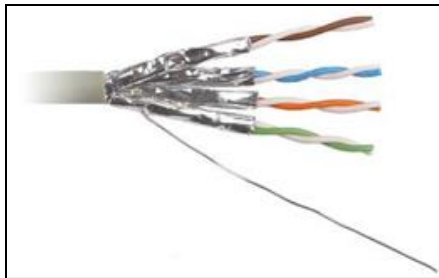

Because the grounding wire is used, the network also uses an RJ45 iron shell.



If the noise interference source is too large, and the network cable with the iron shell and shielded foil twisted pair, it still has communication abnormality, you can add a filter magnetic ring to the network cable.



3. It is recommended that the Ethernet route between stations be at least more than 60 cm.

The place near the RJ45 connector loses the characteristics of the twisted pair.



If the wire is shorter, the larger the ratio of untwisted wire/normally stranded wire, which will reduce the electrical performance of this section of wire.

For this reason, the shortest cable length is 1 or 1.5 meters to ensure its electrical performance.

4. Don't twine the wires connecting the AMAX module with other wires.
All these items above are to avoid noise.

About wiring method for power and Grounding, users have to inspect few items below:

1. Earthing and Grounding

In order to provide the highest immunity against electromagnetic disturbances as well as undesired noise, all the electronic components and chassis enclosures or metallic pathways within the machine or plant should be kept at the same reference potential by means of suitable earthing connections. According to the ISO/IEC 61918 specification,

two earthing schemes have proven to be effective in the industrial environment: equipotential and star.

2. Equipotential Earthing

In the equipotential earthing, devices chassis and pathways are connected wherever possible to the building metallic structure, which is in turn connected to the functional earth. The below shows this scheme. This forms a mesh providing the same reference potential to all EtherCAT devices and infrastructure components. Note that the negative power terminal and earth may possess different potentials, do not connect them together to prevent disturbances.

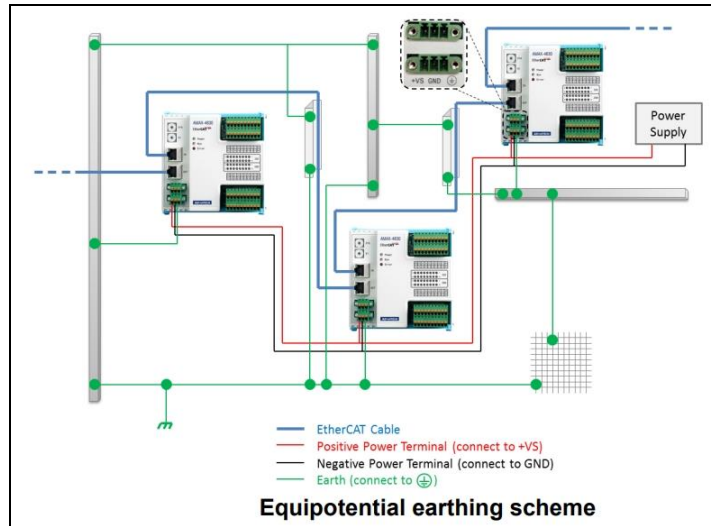

3. Star Earthing

In case medium or high currents are generated within the application, earth paths would form current loops which could in turn determine potential differences among network devices. In this case, a star connection to a single point which is in turn connected to the functional earth could represent a more effective earthing solution. This is shown in below. Note that the negative power terminal and earth may possess different potentials, do not connect them together to prevent disturbances.

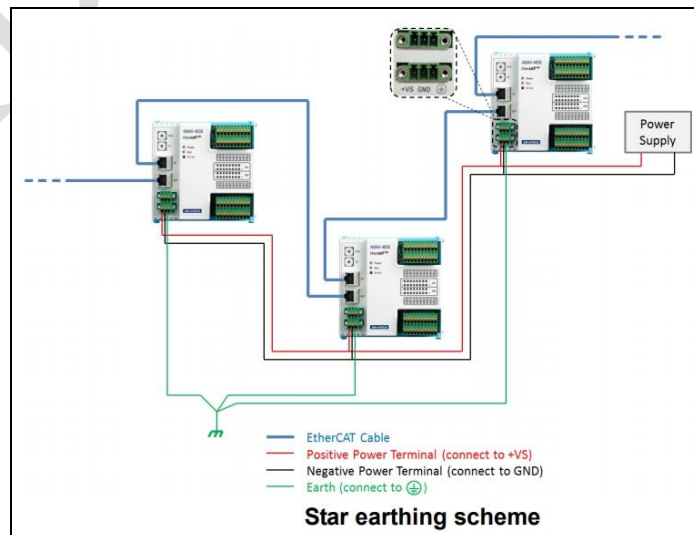

4. Power Separation

To maintain a stable power for control circuitry in the EtherCAT slave I/O modules, it is strongly recommended to use a separate power supply for other heavily loaded or noisy devices, such as high power converters and amplifiers, contactors, solenoids, motors, motor-drives, and sensors. The below shows this power separation scheme.

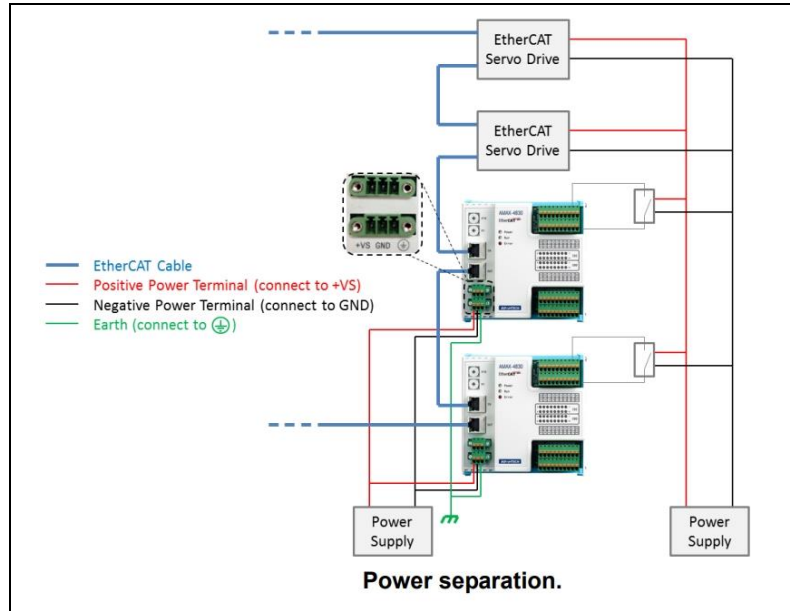

For more robust system design, galvanic isolation between the two power domains can be applied, as shown in below.

