

User Manual

PIT-1702

Patient Infotainment Terminal

ADVANTECH

Enabling an Intelligent Planet

Copyright

The documentation and the software included with this product are copyrighted 2011 by Advantech Co., Ltd. All rights are reserved. Advantech Co., Ltd. reserves the right to make improvements in the products described in this manual at any time without notice. No part of this manual may be reproduced, copied, translated or transmitted in any form or by any means without the prior written permission of Advantech Co., Ltd. Information provided in this manual is intended to be accurate and reliable. However, Advantech Co., Ltd. assumes no responsibility for its use, nor for any infringements of the rights of third parties, which may result from its use.

Acknowledgements

Intel and Pentium are trademarks of Intel Corporation.

Microsoft Windows and MS-DOS are registered trademarks of Microsoft Corp.

All other product names or trademarks are properties of their respective owners.

Declaration of Conformity

FCC Class B

Note: This equipment has been tested and found to comply with the limits for a Class B digital device, pursuant to part 15 of the FCC Rules. These limits are designed to provide reasonable protection against harmful interference in a residential installation. This equipment generates, uses and can radiate radio frequency energy and, if not installed and used in accordance with the instructions, may cause harmful interference to radio communications. However, there is no guarantee that interference will not occur in a particular installation. If this equipment does cause harmful interference to radio or television reception, which can be determined by turning the equipment off and on, the user is encouraged to try to correct the interference by one or more of the following measures:

- Reorient or relocate the receiving antenna.
- Increase the separation between the equipment and receiver.
- Connect the equipment into an outlet on a circuit different from that to which the receiver is connected.
- Consult the dealer or an experienced radio/TV technician for help.

Warning! *Any changes or modifications made to the equipment which are not expressly approved by the relevant standards authority could void your authority to operate the equipment.*



Caution! *Danger of explosion if battery is incorrectly replaced. Replace only with the same or equivalent type recommended by the manufacturer. Dispose of used batteries according to the manufacturer's instructions.*



Part No. 2008170201

Printed in Taiwan

Edition 2

August 2011

Technical Support and Assistance

1. Visit the Advantech web site at www.advantech.com/support where you can find the latest information about the product.
2. Contact your distributor, sales representative, or Advantech's customer service center for technical support if you need additional assistance. Please have the following information ready before you call:
 - Product name and serial number
 - Description of your peripheral attachments
 - Description of your software (operating system, version, application software, etc)
 - A complete description of the problem
 - The exact wording of any error messages

- Warning!**
- 
1. *Input voltage is rated 18-19 VDC, 3 A (DC Mode).*
 2. *Packing: Please carry the unit with both hands; handle with care.*
 3. *Maintenance: to properly maintain and clean the surfaces, use only approved products or clean with a dry applicator.*

Safety Instructions

1. Read these safety instructions carefully.
2. Keep this User Manual for later reference.
3. Disconnect this equipment from any AC outlet before cleaning. Use a damp cloth. Do not use liquid or spray detergents for cleaning.
4. For plug-in equipment, the power outlet socket must be located near the equipment and must be easily accessible.
5. Keep this equipment away from humidity.
6. Put this equipment on a reliable surface during installation. Dropping it or letting it fall may cause damage.
7. The openings on the enclosure are for air convection. Protect the equipment from overheating. **DO NOT COVER THE OPENINGS.**
8. Make sure the voltage of the power source is correct before connecting the equipment to the power outlet.
9. Position the power cord so that people cannot step on it. Do not place anything over the power cord.
10. All cautions and warnings on the equipment should be noted.
11. If the equipment is not used for a long time, disconnect it from the power source to avoid damage by transient overvoltage.
12. Never pour any liquid into an opening. This may cause fire or electrical shock.
13. Never open the equipment. For safety reasons, the equipment should be opened only by qualified service personnel.
14. If one of the following situations arises, get the equipment checked by service personnel:
 - a. The power cord or plug is damaged.
 - b. Liquid has penetrated the equipment.
 - c. The equipment has been exposed to moisture.
 - d. The equipment does not work well, or you cannot get it to work according to the user's manual.
 - e. The equipment has been dropped and damaged.
 - f. The equipment has obvious signs of breakage.
15. **DO NOT LEAVE THIS EQUIPMENT IN AN ENVIRONMENT WHERE THE STORAGE TEMPERATURE MAY GO BELOW -20° C (-4° F) OR ABOVE 60° C (140° F). THIS COULD DAMAGE THE EQUIPMENT. THE EQUIPMENT SHOULD BE IN A CONTROLLED ENVIRONMENT.**
16. If your computer clock loses a significant amount of time or the BIOS configuration resets to default, the battery has no power.

Caution! 1. *Do not replace power adaptor yourself. Please contact a qualified technician or your retail.*



2. *The computer is provided with a battery-powered real-time clock circuit. There is a danger of explosion if battery is incorrectly replaced. Replace only with same or equivalent type recommended by the manufacture. Discard used batteries according to the manufacturer's instructions*

17. CLASSIFICATION:
 - Supplied by Class I adapter
 - No applied parts
 - Continuous operation
 - No AP or APG category
18. Follow national requirements to dispose of unit.
19. Maintenance: To properly maintain and clean the surfaces, use only approved products or clean with a dry cloth.
20. Contact information:
No.1, Alley 20, Lane 26, Rueiguang Road Neihu District, Taipei, Taiwan 114,
R.O.C
TEL: (02) 2792-7818
- 21.



Medical Equipment
With Respect to Electric Shock,
Fire, and Mechanical Hazards Only,
In Accordance with UL 60601-1,
CAN/CSA C22.2 No. 601.1

22. This equipment is not to be used as a life support system.
23. Accessory equipment connected to the analog and digital interfaces must be in compliance with the respective nationally harmonized IEC standards (i.e. IEC 60950 for data processing equipment, IEC 60065 for video equipment, IEC 61010-1 for laboratory equipment, and IEC 60601-1 for medical equipment.) Furthermore all configurations must comply with the system standard IEC 60601-1-1. Anyone who connects additional equipment to the signal input part or signal output part is configuring a medical system, and is therefore, responsible that the system complies with the requirements of the system standard IEC 60601-1-1. The unit is for exclusive interconnection with IEC 60601-1 certified equipment in the patient environment and IEC 60XXX certified equipment outside of the patient environment. If in doubt, consult the technical services department or your local representative.
24. A user must not allow SIP/SOPs and the patient to come into contact with one another at the same time.
25. The sound pressure level at the operator's position according to IEC 704-1:1982 is no more than 70dB (A).

DISCLAIMER: This set of instructions is given according to IEC 704-1. Advantech disclaims all responsibility for the accuracy of any statements contained herein.

Note! Attention, please thoroughly consult the accompanying documentation.



Contents

Chapter 1	Introduction.....	1
1.1	Overview	2
1.2	System Configuration.....	4
Chapter 2	Hardware Description	5
2.1	General Specifications	6
2.1.1	Standard PC Functions.....	6
2.1.2	Flat Panel Interface.....	6
2.1.3	Module Features	6
2.1.4	Power Environment.....	6
2.2	Mechanical Specifications.....	7
2.2.1	Mechanical Specifications (Terminal)	7
2.2.2	Mechanical Specifications (Terminal with Handset)	8
2.2.3	Mechanical Specifications (Terminal with Remote Controller)....	10
2.2.4	Mechanical Drawing for Button I/O	12
2.2.5	Mechanical Drawing for Rear I/O	12
2.3	External View	13
2.3.1	Front View	13
2.3.2	Side View	14
2.3.3	Rear View	14
Chapter 3	Software Description.....	15
3.1	Windows XP Embedded Software Specifications	16
Chapter 4	Design Requirements.....	19
4.1	Environmental Specifications	20
4.2	Reliability	20
Chapter 5	Installation.....	21
5.1	Installation for Terminal.....	22
5.2	Installation for Handset	23
5.3	Installation for Remote Controller.....	24
5.4	Installation for Arm	25

Chapter 1

Introduction

This Chapter briefly introduces the PIT-1702 product.

- Overview
- System Configuration

1.1 Overview

The PIT-1702 Patient Infotainment Terminal is Advantech's standard product with a built-in Windows XP Embedded OS. In addition to providing hospital bedside patient information, remote monitoring, and care functions, the CPU and the LAN-enabled architecture of the PIT-1702 terminal also serves as an integrated hospital gateway device. The PIT-1702 equipped with an Intel Celeron M 1.06 GHz processor, 17" touchscreen, onboard Ethernet, and audio, plays a key role as a hospital bedside care and monitoring solution. It connects the service calls and LED light signals of a hospital room through the LAN to the hospital administration center or nurse station.



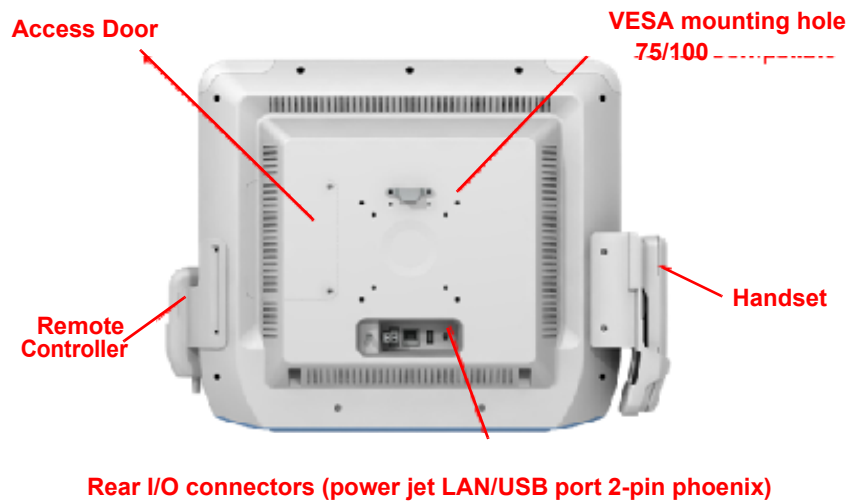
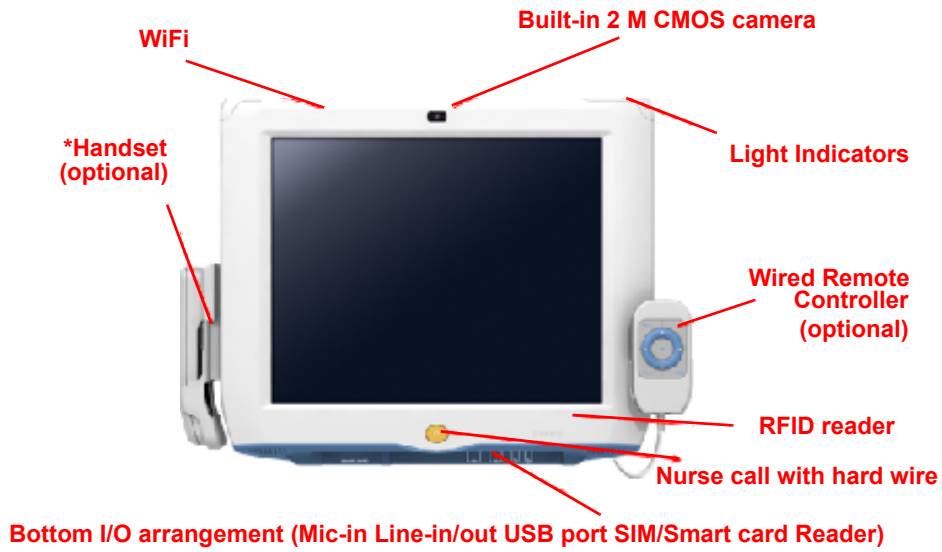

1.2 System Configuration

The block diagram of a PIT-1702 Patient Infotainment Terminal based on Hospital bedside environment is shown in the following diagram:

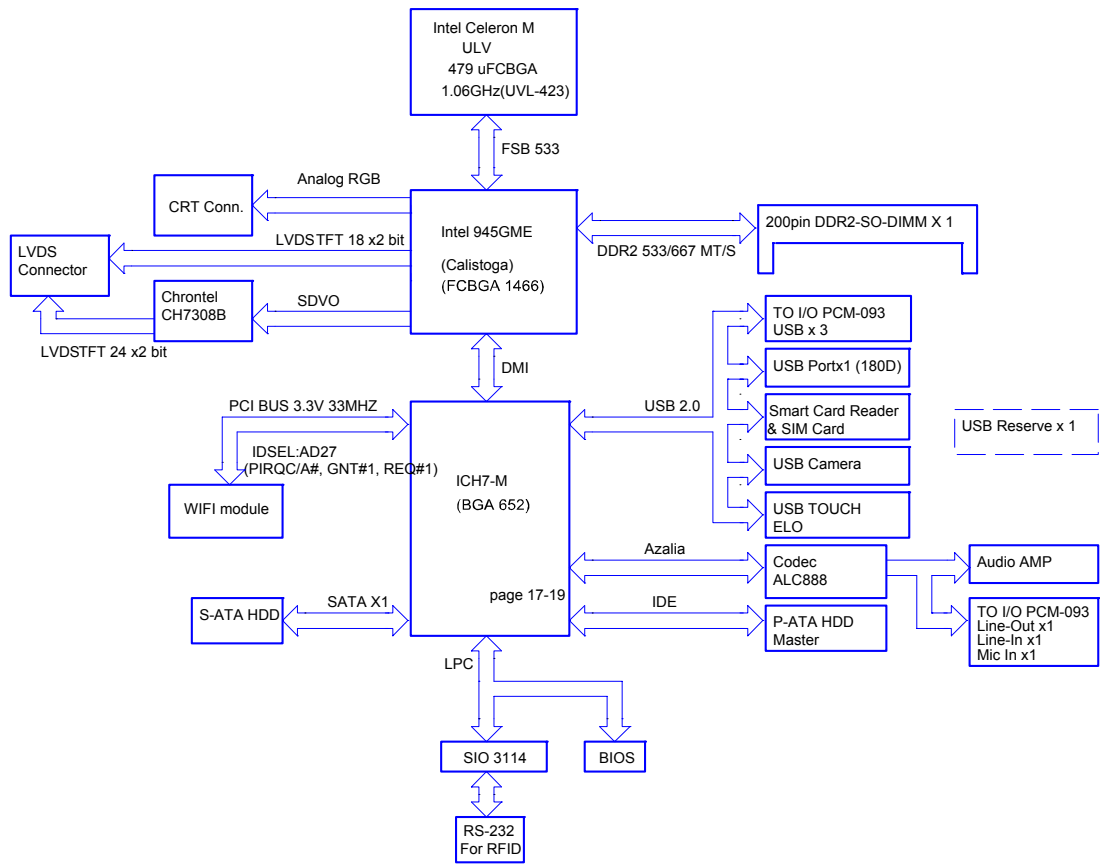

Chapter 2

Hardware Description

This Chapter describes the hardware features of the PIT-1702.

- Main Specifications
- General Specifications
- Mechanical Specifications
- External View

2.1 General Specifications

2.1.1 Standard PC Functions

- **CPU:** Intel® Celeron M 1.06 MHz up to Core™ 2 Duo 1.06 GHz
- **BIOS:** Award 512 K x 8 (4 Mbit) Flash BIOS
- **Chipset:** Intel 945GME + ICH7M
- **Front side bus:** Supports 533/667 MHz
- **Memory:** DDR2 SODIMM 533/667 MHz up to 2 GB
- **Audio:** HD audio codec ALC888 + 2 x 2.2 W amplifier
- **LAN:** Marvell Yukon 88E8053 PCI-E Gigabit Ethernet controller,
- **SDVO/LVDS:** Chrontel CH7308B SDVO to LVDS 48-bit transmitter
- **Universal serial bus (USB) port:** Supports up to 8 USB ports, 5 port for internal I/O(RFID/Touch/CCD/KB), 3 ports for external I/O
- **Mini PCI bus expansion slot:** Accepts one type III mini PCI bus Card
- **Disk drive housing:** Space for one 2.5" SATA HDD
- **LED indicator:** left and right side (orange)

2.1.2 Flat Panel Interface

- **Power button:** With LED indicator
- **Audio:** Mic-in, Line-out
- **USB:** USB x 2
- **LAN:** Gigabit LAN
- **SPK+MIC:** build-in 2 x 2 W SPK + EM147 MIC
- **Button:** GPIO Programmable function
- **Smart card reader:** ISO7816 for IC card standard, PC/SC 1.0 for Windows, smart card standard, Microsoft WHQL, EMV for Europay MasterCard Visa standard and USB-IF CCID standard

2.1.3 Module Features

Features	Interface	Description
Wi-Fi Wireless	Mini PCI	802.11b&g
RFID Kit	Internal USB	13.56 MHz, ISO-15693
Camera module	Internal USB	2 M pixels CMOS camera
LED module	GPIO	Programmable, orange light
Handset module	RJ12	Build-in SPK & MIC
Remote controller	RJ12	Micro controller, up to 9 keys

2.1.4 Power Environment

- **Power adaptor:** AC/DC
 - Input voltage: 100 Vac ~ 240 Vac
 - Output voltage: 19 V @ 3.79 A
- **Medical adaptor:** AC/DC
 - Input voltage: 100 Vac ~ 240 Vac
 - Output voltage: 18 V @ 4.44 A

2.2 Mechanical Specifications

2.2.1 Mechanical Specifications (Terminal)

- **System Dimensions:** 448 (W) x 392.2 (H) x 73.5 (D) mm

Front Cover:

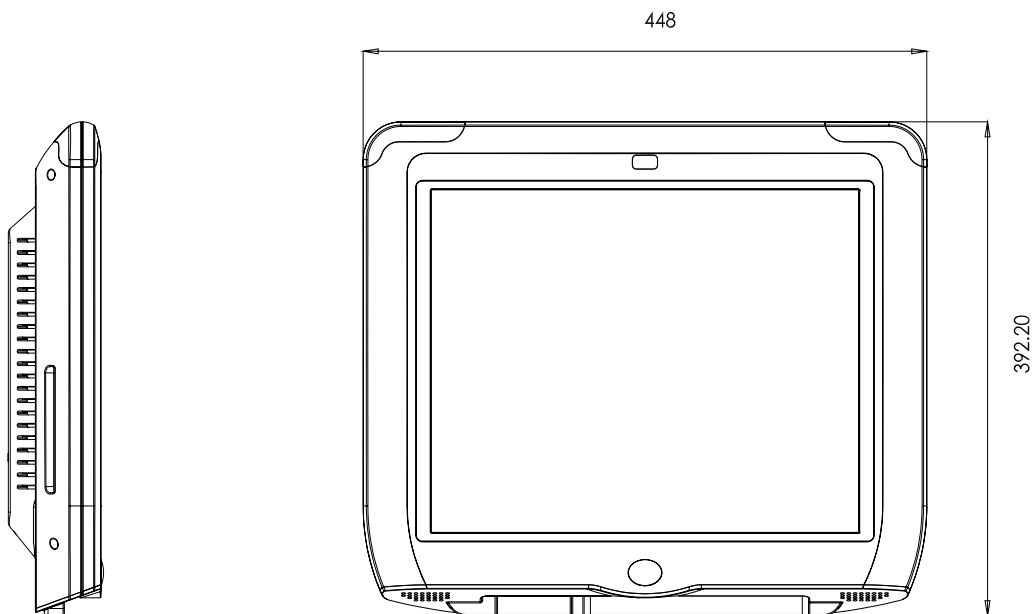

Rear Cover:

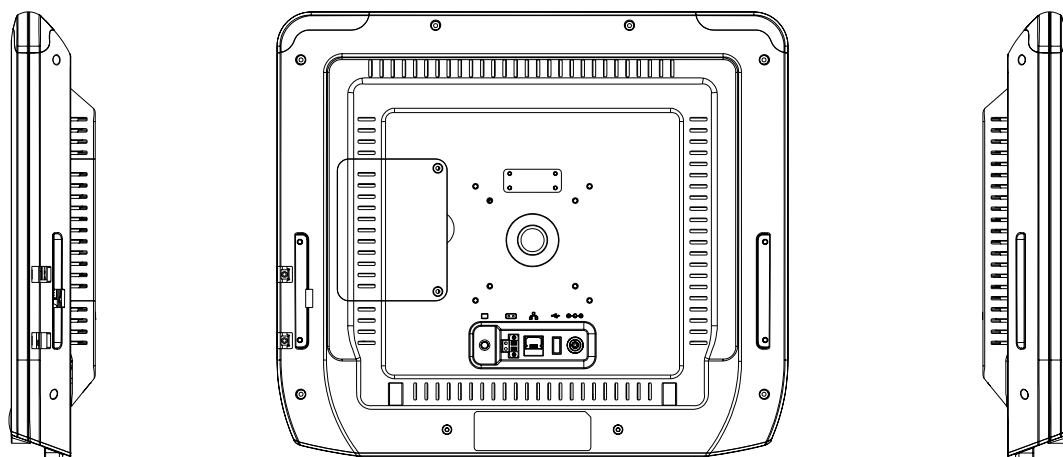

- **Carton Dimensions:** 650 (W) x 610 (H) x 180 (D) (excludes accessories box)
- **Mounting System:** Back box for wall mounting
- **Gross Weight:** 7.0 kg
- **Net Weight:** 5.7 kg

2.2.2 Mechanical Specifications (Terminal with Handset)

- **System Dimensions:** 494.5 (W) x 392.2 (H) x 73.5 (D) mm

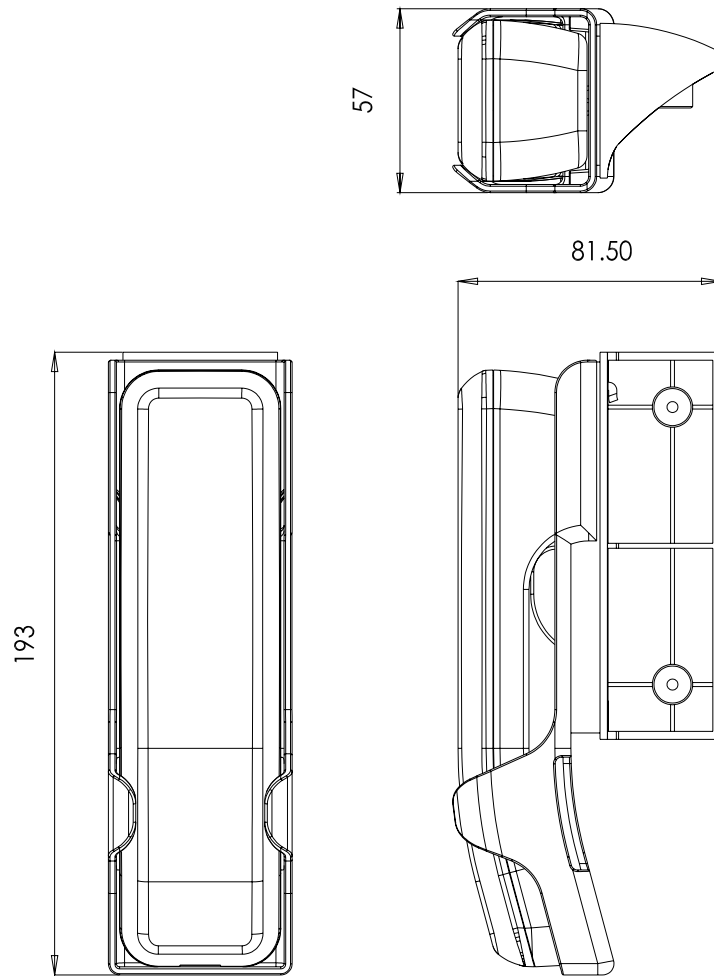

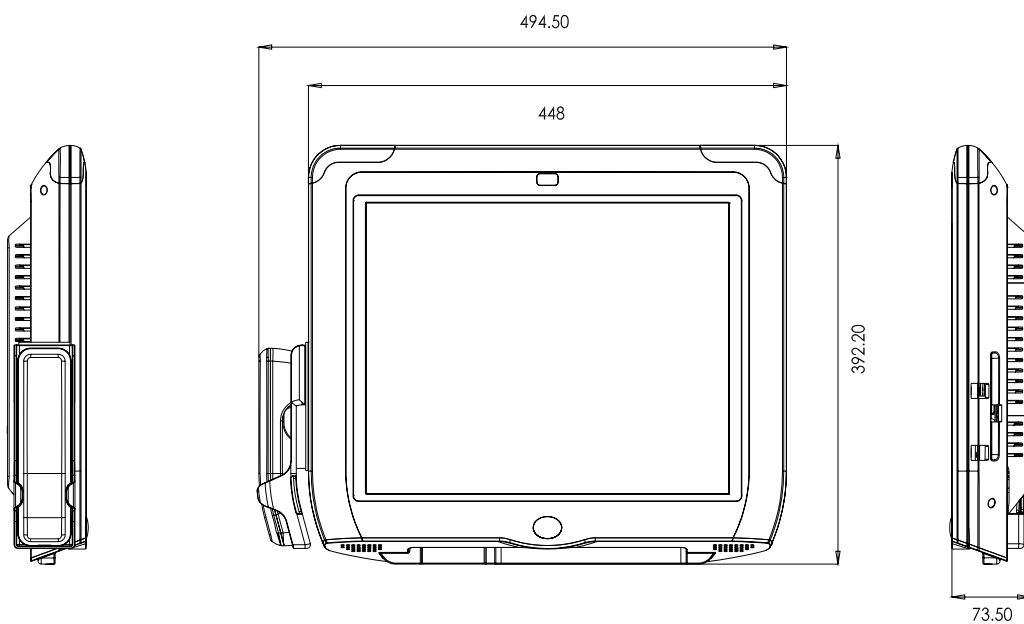
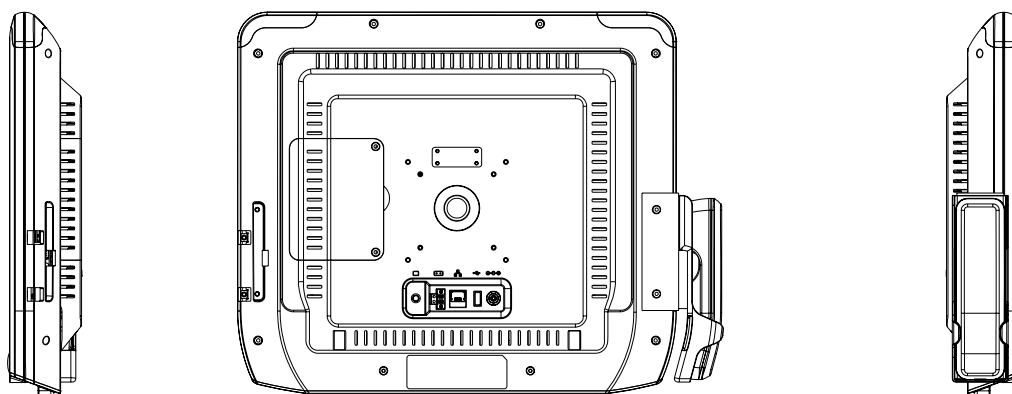
Front Cover:**Rear Cover:**

- **Carton Dimensions:** 650 (W) x 610 (H) x 180 (D) (exclude accessories box)
- **Mounting System:** Back box for wall mounting
- **Gross Weight:** 7.0 kg
- **Net Weight:** 5.7 kg

2.2.3 Mechanical Specifications (Terminal with Remote Controller)

- **System Dimensions:** 532.3 (W) x 392.2 (H) x 73.5 (D) mm

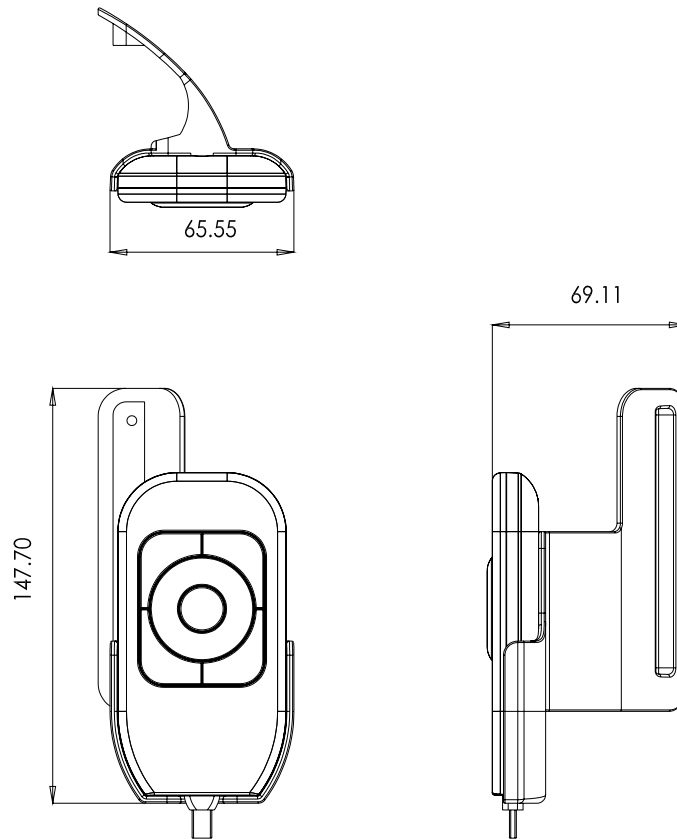

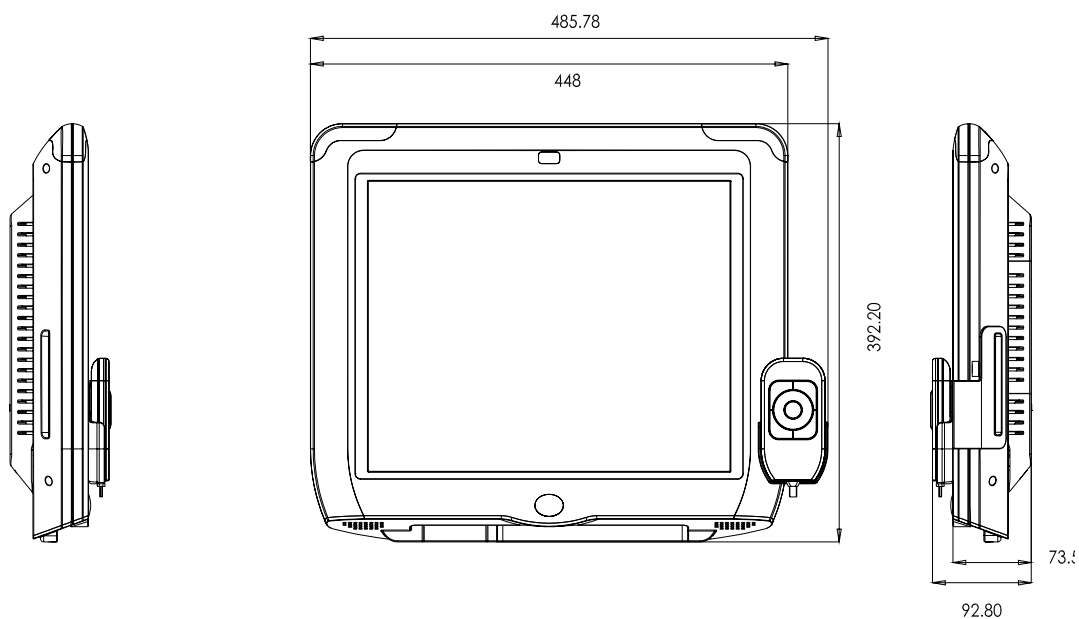
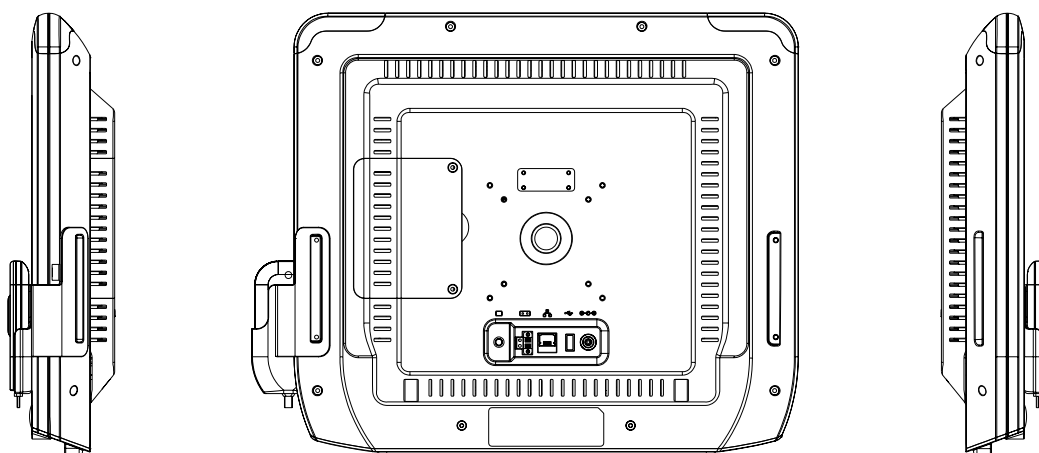
Front Cover:**Rear Cover:**

- **Carton Dimensions:** 455 (W) x 405 (H) x 165 (D) mm
- **Mounting System:** Back box for wall mounting
- **Gross Weight:** 7.0 kg
- **Net Weight:** 5.7 kg

2.2.4 Mechanical Drawing for Button I/O

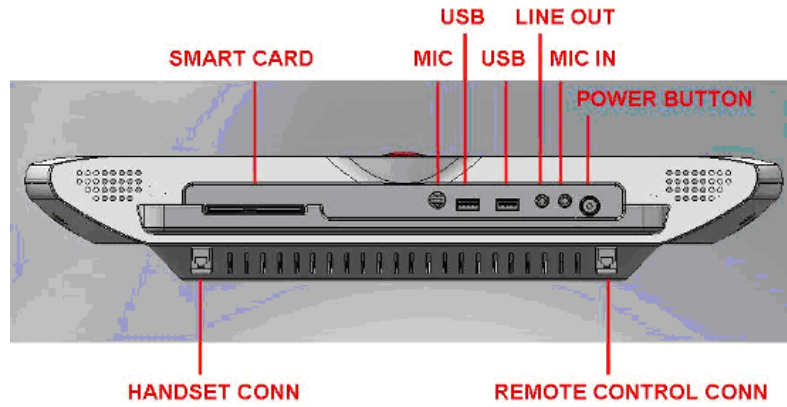

2.2.5 Mechanical Drawing for Rear I/O

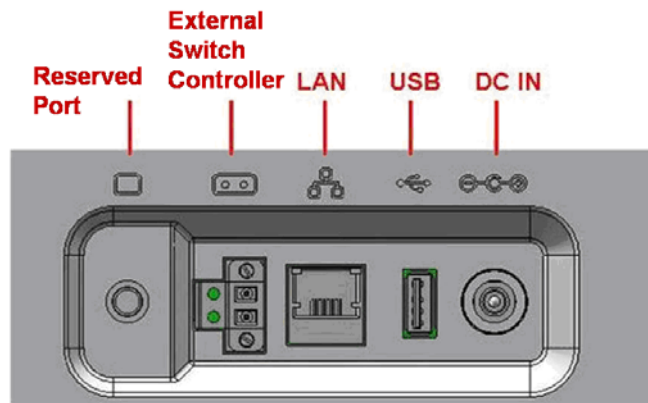

*External Switch Controller: Control port for LCD on/off switch on front panel.

2.3 External View

2.3.1 Front View

Front View (Terminal)



Front View (Terminal with Remote Controller)



Front View (Terminal with Remote Controller & Handset)



2.3.2 Side View



2.3.3 Rear View

Rear View (Terminal)



Chapter 3

Software Description

This Chapter describes the software features of the PIT-1702.

- Windows XP Embedded Software Specifications

3.1 Windows XP Embedded Software Specifications

Real-Time OS Kernel

- Windows XPE 7 Language Version

Driver List

■ Chipset	Intel 945GME	Rev: 8.3.1.1009
■ Graphics	Intel GMA950	Rev: PV 14.31
■ Audio	Realtek Audio ALC880	Rev: 5.10.0.5512
■ LAN	Marvell Yukon Ethernet Controller	Rev: 8.61.7.3
■ Camera	D-Max UVC 2 M Webcam	Rev: 6.11.200.4
■ Smartcard reader	ALCOR micro USB smartcard reader	Rev: 5.11.9520.7
■ Touch	Elo TtouchSys. 2216 AccuTouch@USB	Rev: 4.4.0.0
■ WLAN	Qcom WIFI module	Rev:1.2.3.0

Embedded Application Software

- Advantech SUSI

SUSI Demo Program



1. LED Indicator Control.

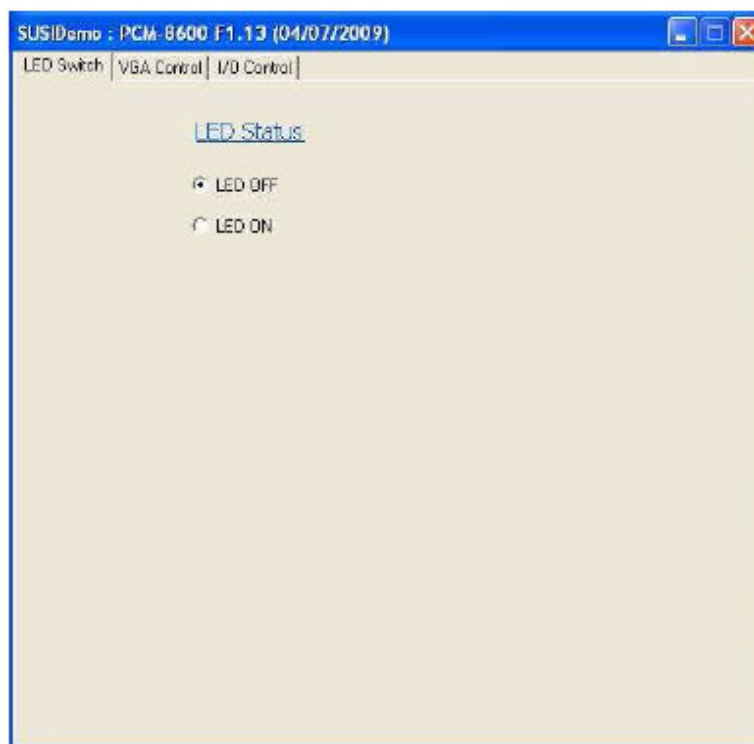

2. LCD Panel Brightness Control.

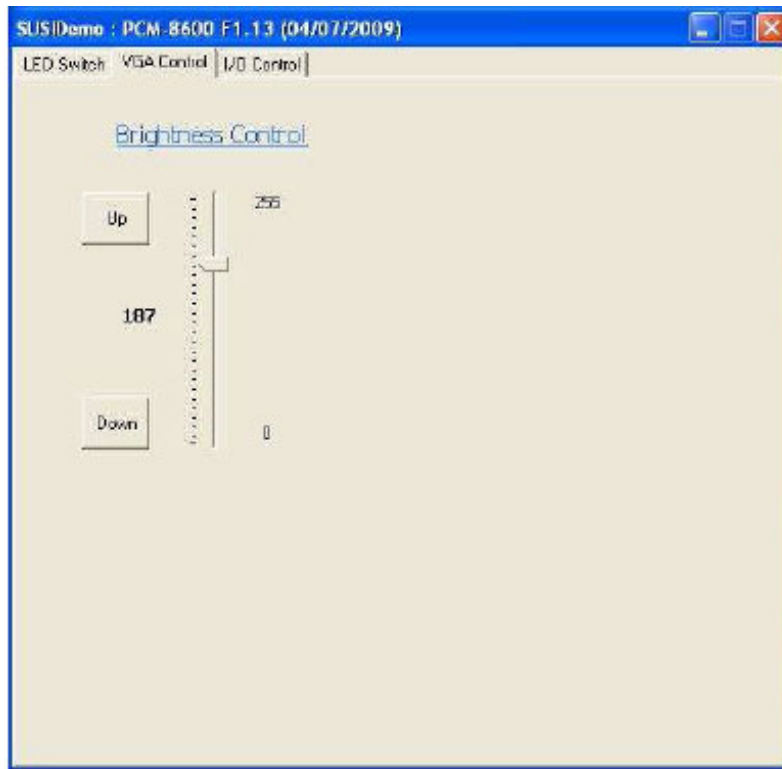

3. Nurse Call (GPIO function) Control.



Search for more information in *D:\Drivers for PIT-1702 series\Advantech\SUSI Documentations.

Note! The CD-ROM drive is designated as D.



Chapter 4

Design Requirements

This Chapter describes the design requirements of the PIT-1702.

- Environmental Specifications
- Reliability

4.1 Environmental Specifications

Temperature & Humidity

- Operating Temperature: 0 ~ 40° C
- Storage Temperature: 0 ~ 60° C
- Relative Humidity: 0 ~ 95% RH (Non-condensed)

Case / Panel Temperature

- Less than 40° C @ 25° C ambient temperature (front bezel)

Safety

- CE

EMI

- FCC class B approved

Vibration:

- 10 ~ 18 Hz, 1.5 mm peak-to-peak displacement
- 18 ~ 500 Hz, 1 G acceleration

4.2 Reliability

MTBF

- 20,000 hours

Touchscreen

- 1 million touch actuation times on a single point with a 5/8" diameter silicon finger under a 350 g load at 2 Hz
- **Power Requirements**
- DC Input Voltage: 19 V
- Power Consumption: less than 60 W

Chapter 5

Installation

This Chapter describes the installation of the PIT-1702.

- Installation for Terminal
- Installation for Handset
- Installation for Remote Controller
- Installation for Arm

5.1 Installation for Terminal

Step 1. Fix Hook.

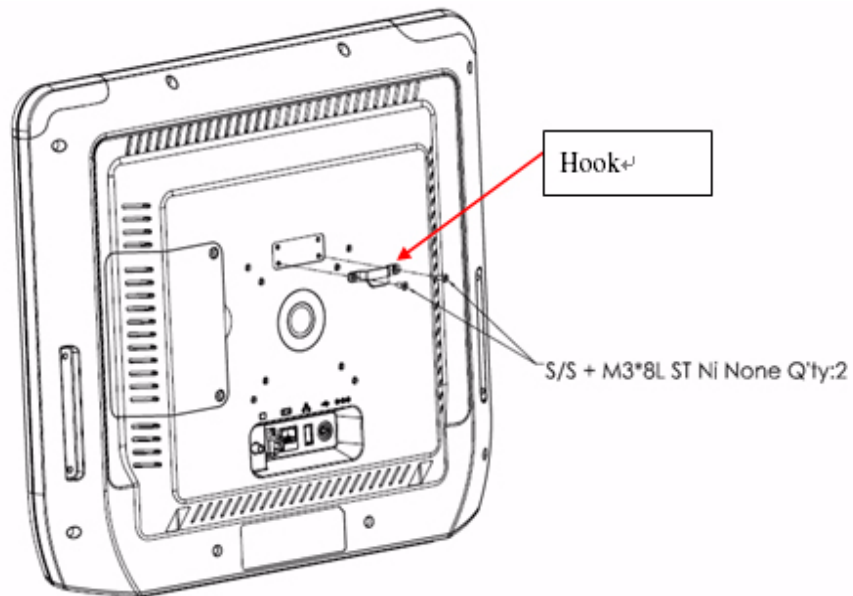

Step 2. Fix ARM + Handset Bracket + Remote Control Bracket.

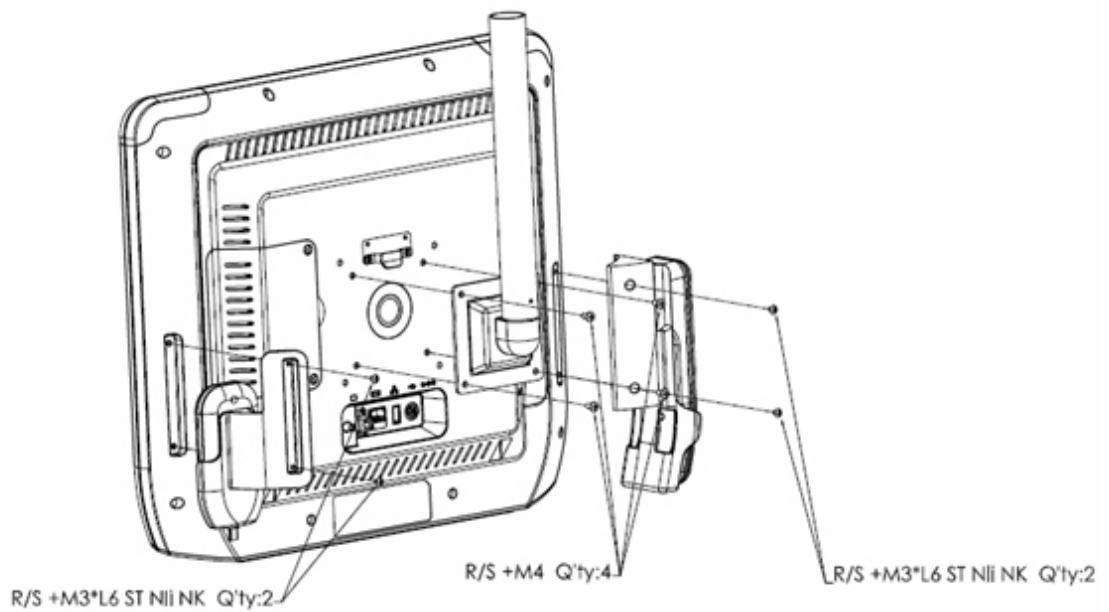

5.2 Installation for Handset

Step 1. Fix Hook.

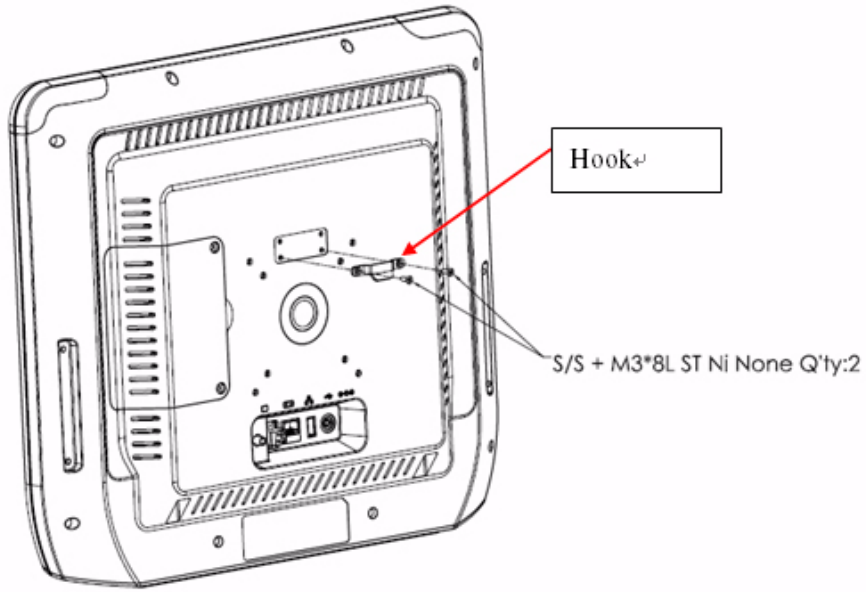

Step 2. Fix ARM + Handset Bracket + Handset.

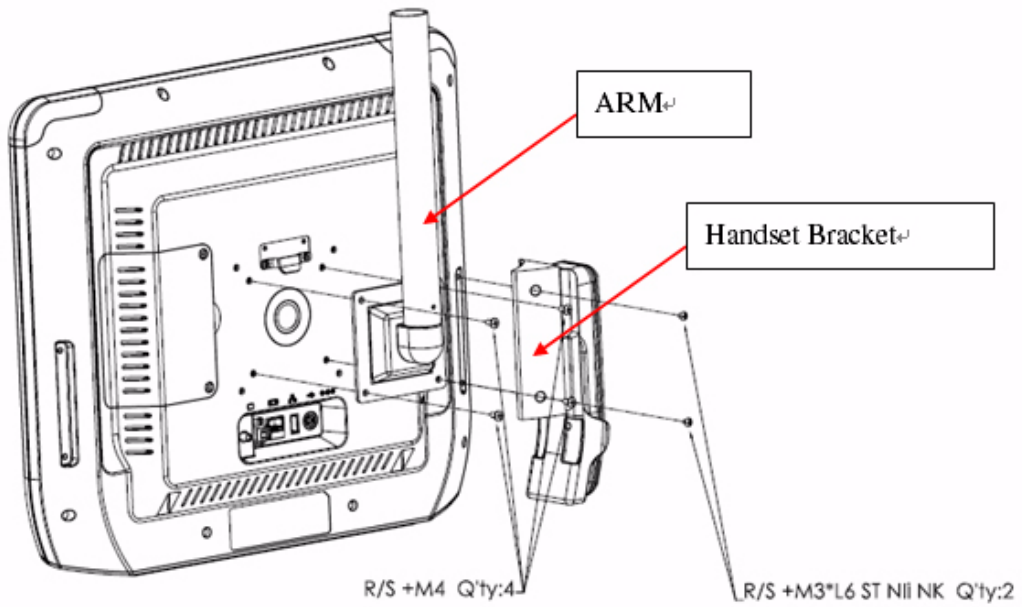

5.3 Installation for Remote Controller

Step 1. Fix Hook.

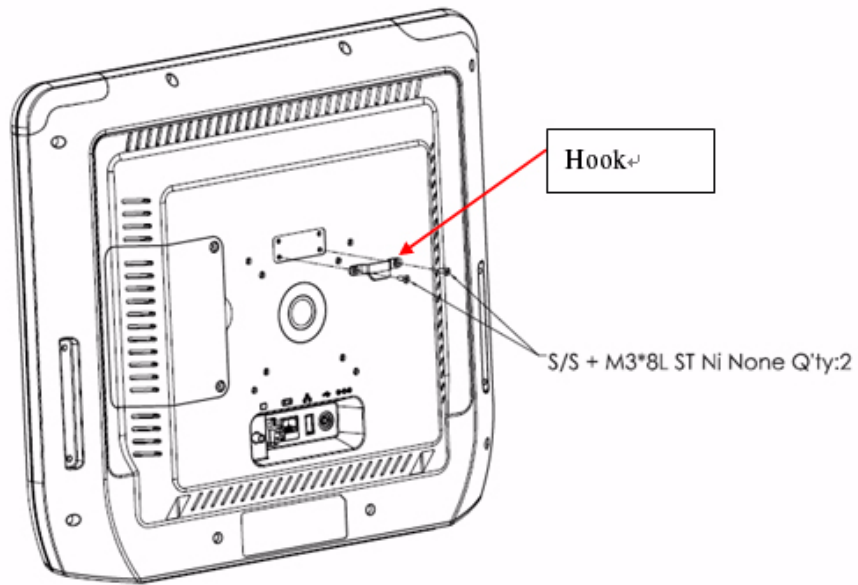

Step 2. Fix ARM + Handset Bracket + Remote Control Bracket.

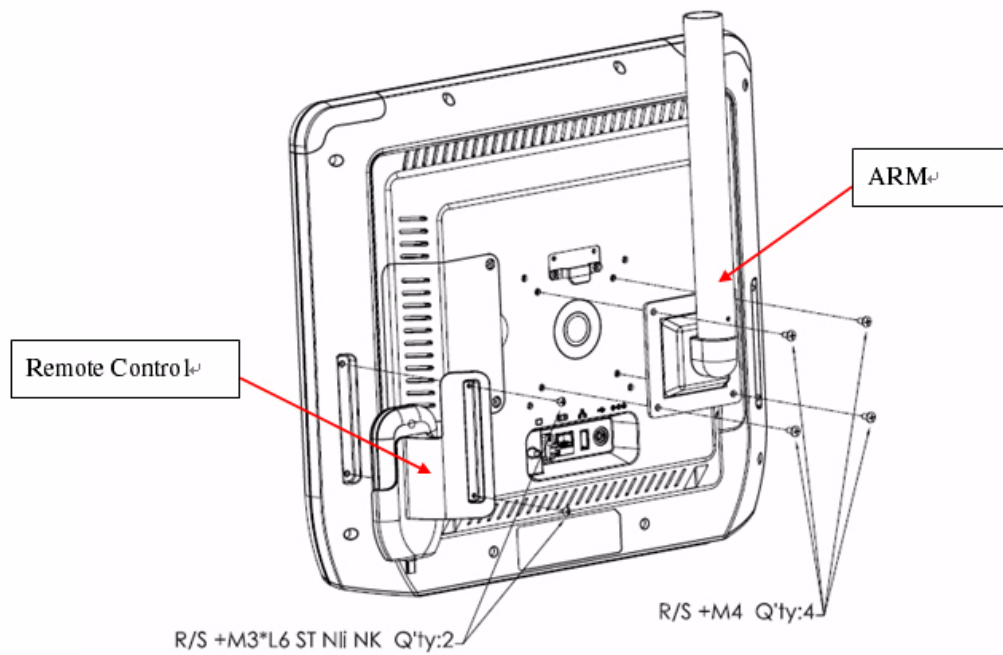

5.4 Installation for Arm

Step 1. Fix Hook.

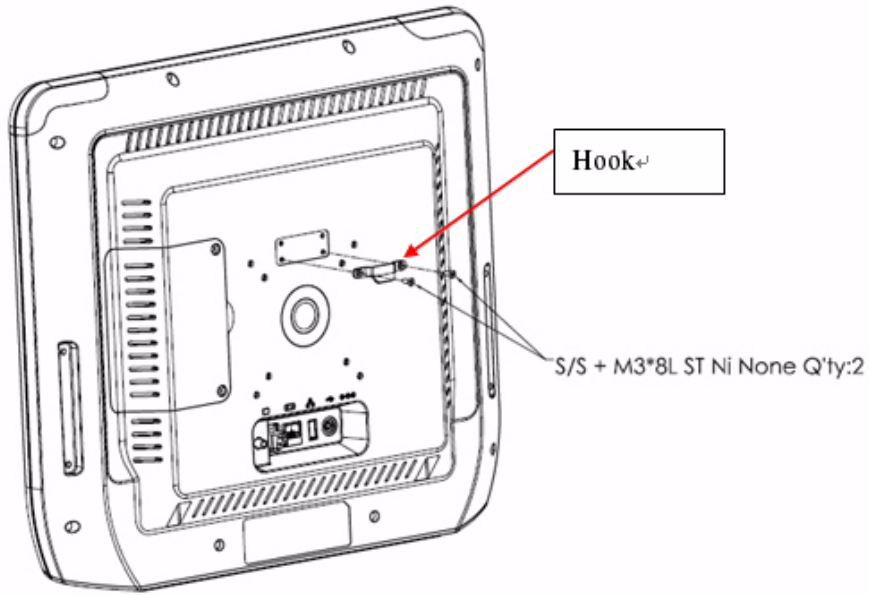

Step 2. Fix ARM + Handset Bracket + Handset.

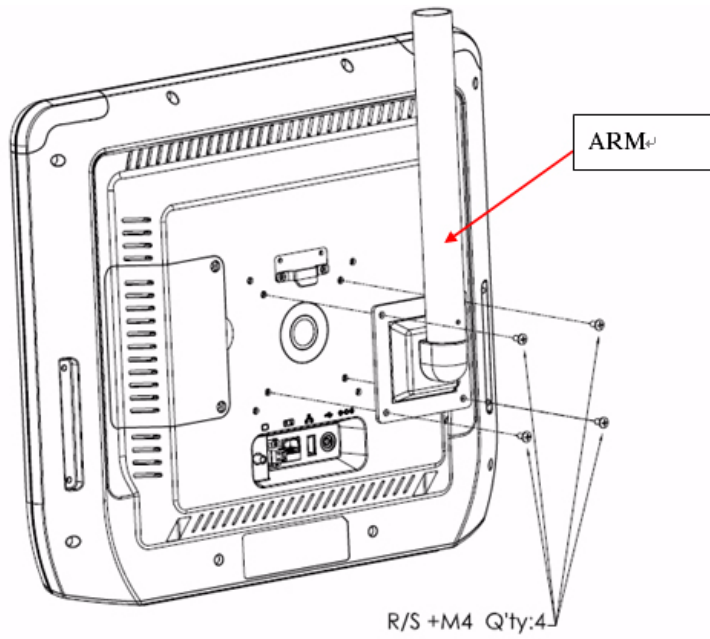

ADVANTECH

Enabling an Intelligent Planet

www.advantech.com

Please verify specifications before quoting. This guide is intended for reference purposes only.

All product specifications are subject to change without notice.

No part of this publication may be reproduced in any form or by any means, electronic, photocopying, recording or otherwise, without prior written permission of the publisher.

All brand and product names are trademarks or registered trademarks of their respective companies.

© Advantech Co., Ltd. 2011