

**TEAC DW-224E-R83  
CD-RW/DVD-ROM DRIVE**

---

**HARDWARE SPECIFICATION**

**Rev. A**

## TABLE OF CONTENTS

Title	Page
1. SCOPE .....	1
2. OUTLINE .....	1
3. CONSTRUCTION .....	2
3.1 External Construction .....	2
3.2 Installation .....	4
4. DISC SPECIFICATION .....	5
4.1 Applicable Disc Format .....	5
4.2 Rotational Speed .....	5
4.3 Data Capacity .....	6
4.4 Write methods .....	6
4.5 Readable disc .....	6
4.6 Recordable Disc (Recording Speed) .....	6
5. PERFORMANCE .....	7
5.1 Operating Performance .....	7
5.2 Audio .....	7
5.3 Acoustic Noise .....	7
6. ENVIRONMENTAL CONDITIONS .....	8
7. RELIABILITY .....	9
8. SAFETY STANDARDS .....	9
9. FRONT INDICATOR .....	9
10. DRIVE CONFIGURATION .....	9
11. INTERFACE CONNECTOR .....	10
12. AUDIO INTERFACE .....	11
13. POWER INTERFACE .....	11
14. IDE HARDWARE INTERFACE .....	12
14.1 Outline .....	12
14.2 Electrical Characteristics .....	12
14.3 Input/Output Signals .....	13
14.4 Interface Timing .....	14
14.5 COMMAND SET .....	26
14.5.1 ATA COMMAND .....	26
14.5.2 ATAPI COMMAND .....	27
15. POWER MANAGEMENT SPECIFICATION .....	29
15.1 Power Management Modes .....	29
15.1.1 Transition in power management mode .....	29
15.2 Active Mode .....	30
15.3 Idle Mode .....	30
15.4 Standby Mode .....	31
15.5 Sleep Mode .....	31
15.5.1 Tray ejection/insertion in the sleep mode .....	31
16. OTHERS .....	31
16.1 Using the lens cleaner .....	31
16.2 Safety of Laser Products .....	32

## 1. SCOPE

This is hardware specification of the TEAC DW-224E-R83 built-in type CD-RW/DVD-ROM drive (hereinafter referred to as drive). As for the software specification, refer to "DW-224E-R Software Specification".

## 2. OUTLINE

The outline of this drive is given in Table 2-1.

(Table 2-1) Outline of the specification

Model name	DW-224E-R83
TEAC P/N	1977098R-83
Applicable safety standards	UL, CSA, TÜV, CE
Data transfer rate (burst)	33.3MBytes/sec max
Average access time	90msec (CD-ROM)/110msec (DVD-ROM), average by TEAC standards
Disc speed (24X CAV speed mode)	5,090min <sup>-1</sup> (Approx)
Host interface	IDE (ATAPI)
Power source	+5VDC
Starting time	19sec max
Readable discs	CD/CD-ROM (12cm, 8cm) CD-R (Recorded) CD-RW (Recorded) DVD-ROM DVD-R (Recorded) DVD-RW (Recorded) DVD-RAM (Recorded) DVD+R (Recorded) DVD+RW (Recorded)
Recordable disc	CD-R/RW disc (Refer to item 4.6)
Applicable format	CD-DA CD-ROM Mode 1, Mode 2 CD-ROM XA Mode 2 (Form 1, Form 2) Photo CD (Single/Multi-session) Enhanced CD CD-TEXT DVD-ROM DVD-R (General. Authoring) DVD-Video DVD-RAM (4.7GB, 2.6GB) DVD+R/RW (Single/Multi-session, Packet)
Write methods	Disc at once, Session at once, Packet write, Track at once
Front bezel	Black
Eject button	Black
Access indicator	Green
Laser class	Class 1 laser product

### **3. CONSTRUCTION**

#### **3.1 External Construction**

- (1) Dimensions
  - (a) Height : 12.7mm (excluding the front bezel)
  - (b) Width : 128mm (excluding the front bezel)
  - (c) Depth : 129.4mm (excluding the eject button)
- (2) Mass : 178g or less
- (3) Disc clamp system : Ball clamp
- (4) Loading : Manual loading using the tray
- (5) Ejection
  - (a) Manual eject using the eject button
  - (b) Automatically eject using the command
  - (c) Eject distance : 10mm or more
- (6) External view : Refer to Fig. 3.1-1.

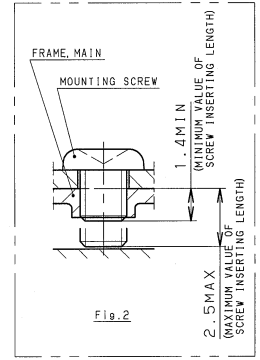
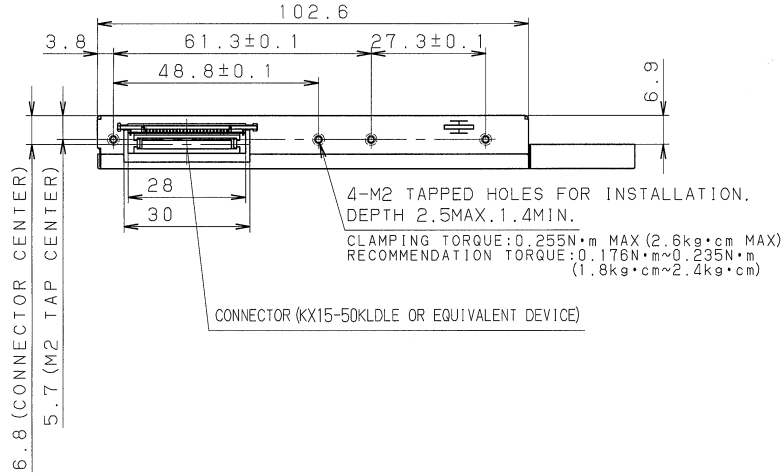
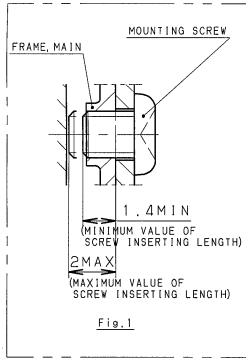

2-M2 TAPPED HOLES FOR INSTALLATION.  
DEPTH 2.5 MAX. 1.4 MIN.  
CLAMPING TORQUE: 0.255 N·m MAX (2.6 kg·cm MAX)  
RECOMMENDATION TORQUE: 0.176 N·m ~ 0.235 N·m  
(1.8 kg·cm ~ 2.4 kg·cm)

4-M2 TAPPED HOLES FOR INSTALLATION.  
DEPTH 2.0 MAX. 1.4 MIN.  
(LEFT SIDE X1, RIGHT SIDE X3)  
CLAMPING TORQUE: 0.255 N·m MAX (2.6 kg·cm MAX)  
RECOMMENDATION TORQUE: 0.176 N·m ~ 0.235 N·m  
(1.8 kg·cm ~ 2.4 kg·cm)

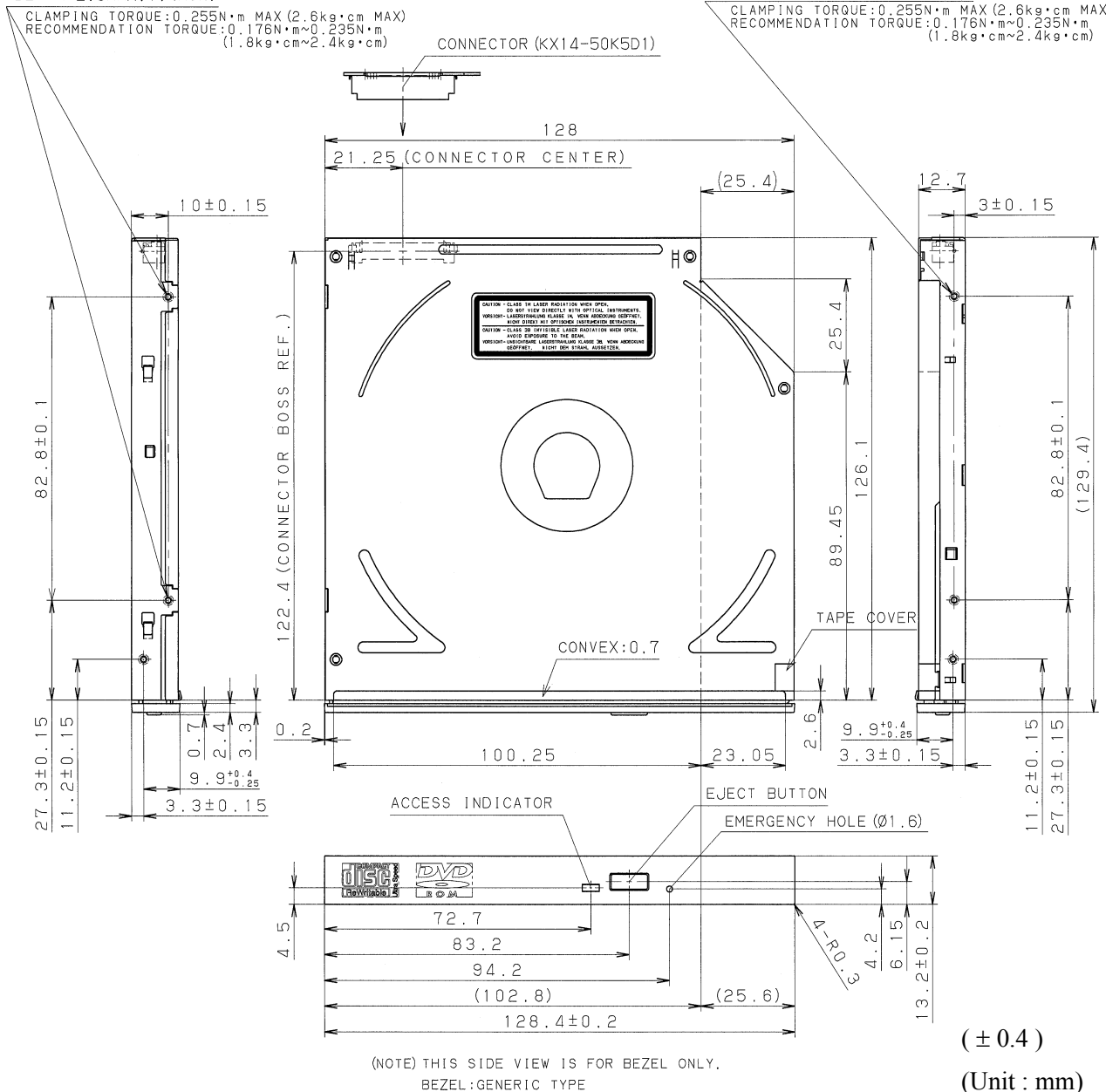

(Fig. 3.1-1) External view of the drive

### 3.2 Installation

- (1) Installation direction : Refer to Fig. 3.2-1
- (2) Tilt : Refer to Fig. 3.2-1 below.
- (3) Installation method : The fixing holes in the side of the unit are used.  
Separate discussions and arrangements are required when the installation holes are not used.

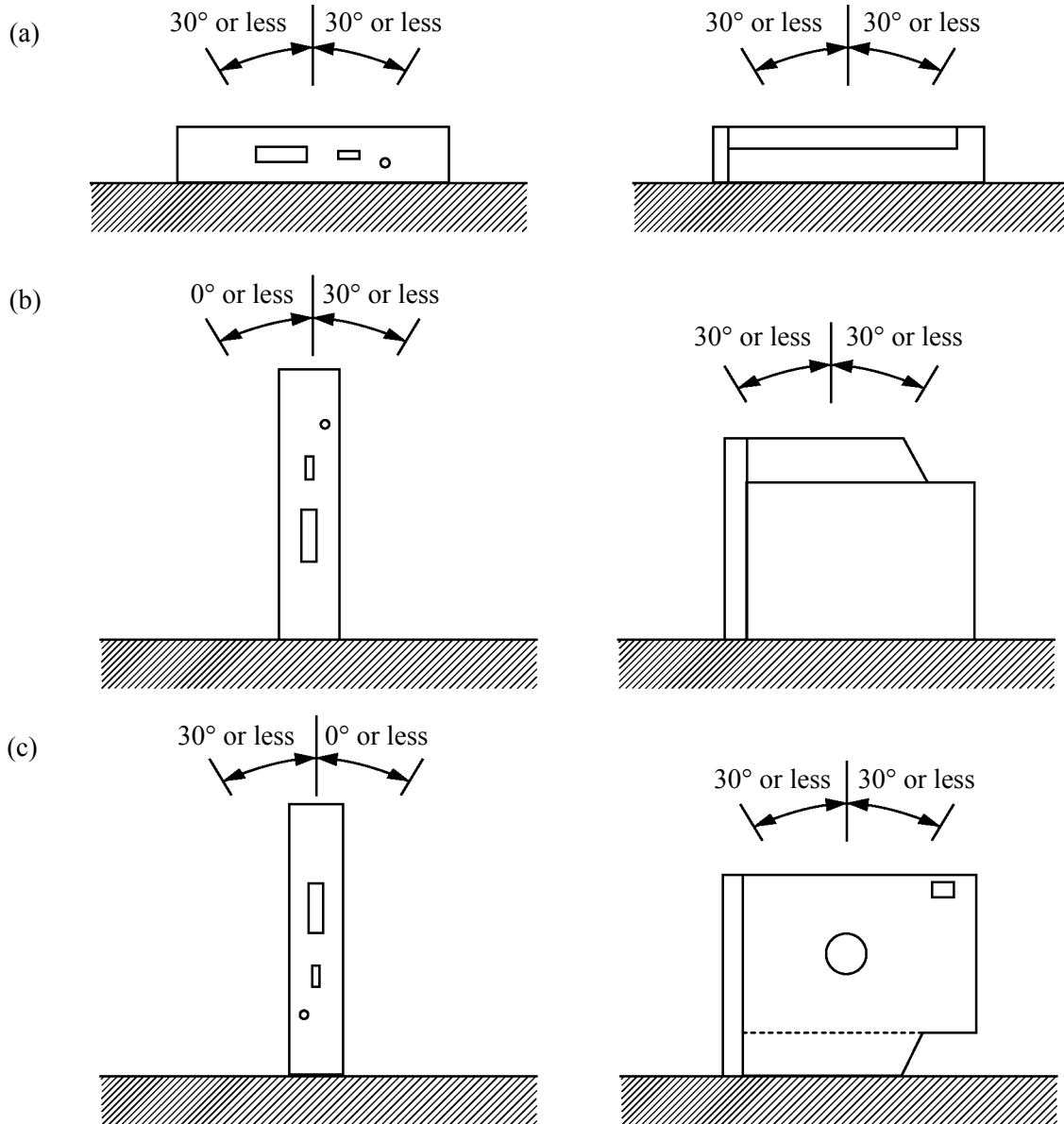

(Fig. 3.2-1) Tilt of the drive

## 4. DISC SPECIFICATION

### 4.1 Applicable Disc Format

- CD-DA
- CD-ROM Mode 1
- CD-ROM XA Mode 2 (Form 1, Form 2)
- Multi-session Photo CD
- CD-I
- Video CD
- Enhanced CD
- CD-TEXT
- DVD-ROM
- DVD-R (General, Authoring)
- DVD-Video
- DVD-RW
- DVD-RAM (4.7GB, 2.6GB)
- DVD+R/RW (Single/Multi-session, Packet)

### 4.2 Rotational Speed

Refer to Table 4.2-1 for the rotational speed.

(Table 4.2-1) Rotational speed (read mode)

Operation/Disc format	Read speed/Disc speed
Idle mode (DVD)	4x CAV 2,297rpm
Idle mode (CD)	10x CAV 2,140rpm
Read (DVD-ROM)	8x CAV 4,594rpm
Read (DVD-Video)	4x CAV 2,297rpm
Read (CD-ROM Model)	24x CAV 5,137rpm
Read (CD-ROM Mode2form2)	20x CAV 4,280rpm
Read (CD-DA)	20x CAV 4,280rpm
Play Audio	4x CLV 856 - 1,984rpm
Mixed (CD-ROM Model and Mode2form2 or CD-DA)	20x CAV 4,280rpm
Mixed (DVD-ROM and DVD-Video)	8x CAV 4,594rpm
CD-RW (Read only operation)	24x CAV 5,137rpm
DVD-R/DVD-RW, DVD+R/DVD+RW	8x CAV 4,594rpm
DVD-RAM (4.7GB)	5x CAV 3,246rpm
DVD-RAM (2.6GB)	2.5x CAV 1,626rpm

**(Table 4.2-2) Rotational speed (Write mode)**

Disc		Read speed/ Disc speed
CD-R		24x CAV 5,137rpm
		16x CAV 3,425rpm
		10x CLV 2,140 - 4,954rpm
		4x CLV 856 - 1,984rpm
CD-RW	Multi speed	4x CLV 856 - 1,984rpm
	High speed	10x CLV 2,140 - 4,954rpm
		10x CAV 2,140rpm
		4x CLV 856 - 1,984rpm
Ultra speed	24x CAV 5,137rpm	

### 4.3 Data Capacity

- 650MB/700MB : CD-ROM Mode 1  
: CD-ROM XA Mode 2 Form 1
- 738MB/795MB : CD-ROM XA Mode 2 Form 2
- 74min/79min : CD-DA
- 4.7GB/side : DVD-ROM, DVD-Video, DVD-R, DVD-RW, DVD-RAM,  
DVD+R, DVD+RW
- 8.5GB/side : DVD-ROM, DVD-Video (Dual layer)
- 2.6GB/side : DVD-RAM

### 4.4 Write methods

Disc at once, Track at once, Session at once, and Packet write

### 4.5 Readable disc

Press CD, Recorded CD-R/RW, Press DVD, Recorded DVD-R, Recorded DVD-RW, Recorded DVD-RAM, Recorded DVD+R, Recorded DVD+RW

### 4.6 Recordable Disc (Recording Speed)

Recommended as the recordable disc to be used in this drive is a 79-minute disc for 8x speed manufactured by Taiyo Yuden Co., Ltd. (TEAC Part No.: T0006613, CD-R80-BULK). The use of other recordable discs is conditional on mutual understanding between TEAC and specific users.

With the recommended type of discs, the following speeds of recording are available:

4x speed, 10x speed, 16x speed and 24x speed

## 5. PERFORMANCE

### 5.1 Operating Performance

- (1) Average random access time : 90msec average (CD-ROM, 24x), 110msec average (DVD-ROM, 8x)
- (2) Disc speed : Refer to 4.2
- (3) Data transfer rate
  - (a) Read sustained : 1,545 to 3,600kB/sec (CD-ROM model)  
4,469 to 10,816kB/sec (DVD-ROM)
  - (b) Programmed I/O : 16.7MB/sec max (Mode 0 to 4)
  - (c) Multi-word DMA : 16.7MB/sec max (Mode 0 to 2)
  - (d) Ultra DMA : 33.3MB/sec max
- (4) Starting time
  - (a) When power is switched on/when disc is loaded : 19sec max (excluding the multi-session CD)
  - (b) Return time from the standby mode : 4sec or less
- (5) Data buffer capacity : 2MB

### 5.2 Audio

- (1) Line output
  - The following specifications apply during audio play.
  - (a) Number of channels : 2 channels (stereo)
  - (b) Frequency response : 20 to 20kHz ( $\pm 3$ dB)
  - (c) Dynamic range : 83dB or more (IHF A, 1kHz, LPF 20kHz)
  - (d) S/N : 85dB or more (IHF A, 1kHz, LPF 20kHz)
  - (e) Distortion factor : 0.05% or less (1kHz, 20kHz LPF)
  - (f) Channel separation : 70dB or more (1kHz, 20kHz LPF)
  - (g) Output level : 0.8Vrms  $\pm 3$ dB (load = 47k $\Omega$  ATT = 0dB)
  - (h) Muting : each channel independent (using the ATAPI command)
  - (i) Volume : Software volume using the ATAPI command;  
255 steps from volume level 0 to  $-\infty$  (infinity) dB; variable for each channel independently.

### 5.3 Acoustic Noise

- (1) Operating : 45dBA or less (during seek/read/write/Active/Idle, distance 0.5m)
- (2) Ejecting : 65dBA or less (distance 0.5m)

## 6. ENVIRONMENTAL CONDITIONS

The environmental conditions as specified here do not include the environmental conditions of the disc. The environmental conditions of the disc should follow the specifications of the applicable disc.

- (1) Ambient temperature
  - (a) During operation : 5 to 45°C (Surface temperature on the top cover; 5 to 50°C)
  - (b) During non-operation : -20 to 60°C
  - (c) During transportation (packaged) : -40 to 65°C
- (2) Temperature gradient
  - (a) During operation : 11°C/hour or less (noncondensing)
  - (b) During non-operation/transportation : 20°C/hour or less (noncondensing)
- (3) Relative humidity
  - (a) During operation : 8 to 80% (noncondensing)  
provided that the maximum wet-bulb temperature is 29.4°C or less.
  - (b) During non-operation/transportation : 5 to 95% (noncondensing)  
provided that the maximum wet-bulb temperature is 29.4°C or less.
  - (c) During transportation (packaged) : 5 to 95% (noncondensing)  
provided that the maximum wet-bulb temperature is 29.4°C or less.
- (4) Vibrations
  - (a) During operation:  
When installed horizontally: 2.9m/s<sup>2</sup> (0.3G) or less  
When installed vertically : 1.96m/s<sup>2</sup> (0.2G) or less  
provided that the sweep frequency is 5 to 500Hz and sweep rate, 1oct/min.  
excepting recording mode.
  - (b) Transportation (packaged) : 19.6m/s<sup>2</sup> (2G) or less provided that the sweep frequency is 5 to 500Hz and sweep rate, 1oct/min.
- (5) Shock
  - (a) During operation (free from malfunction)  
When installed horizontally: 68.6m/s<sup>2</sup> (7G) or less (half-sine shock pulse; 11msec, intervals; 10sec)  
When installed vertically : 49m/s<sup>2</sup> (5G) or less (half-sine shock pulse; 11msec, intervals; 10sec)  
excepting recording mode and CD-DA play mode.
  - (b) During operation (while the CD-DA is playing) : 19.6m/s<sup>2</sup> (2G) or less (half-sine shock pulse; 11msec., intervals; 10sec)
  - (c) During non-operation/transportation : 588m/s<sup>2</sup> (60G) or less (half-sine shock pulse; 11msec)  
1,960m/s<sup>2</sup> (200G) or less (half-sine shock pulse; 2msec)  
However, tray ejection is allowed.
- (6) Dust : office environment
- (7) Cooling : natural air cooling

## 7. RELIABILITY

- (1) Mean time between failures (MTBF)
  - : 60,000POH or more (the frequency of use should be 10% at normal temperature and humidity)
- (2) Mean time to repair (MTTR) : 30minutes
- (3) Loading/ejecting life : 10,000times or more
- (4) Power ON/OFF life : 60,000 times or more
- (5) Laser diode life : MTTF 9,000 hours (Duty 50% pulse 83mW, 60°C)
- (6) Seeking life :  $2 \times 10^6$  times or more (random access, 25°C, duty; 20% or less)
- (7) Error rate
  - (a) Read error rate
    - DVD : Once per  $10^{12}$  bits or less
    - CD : MODE 1 and MODE 2 (FORM 1) : Once per  $10^{12}$  bits or less  
MODE 2 (FORM 2) and CDDA : Once per  $10^9$  bits or less
  - (b) Seek error rate : Once per  $10^6$  seeks or less
  - (c) Seek error rate : Once per  $10^6$  seeks or less
- (8) Self-diagnosis
  - (a) When power is switched ON: Various controllers, ROM, RAM, buffer, ECC circuit, etc.
  - (b) When disc is inserted : Servo circuit, signal processors, etc.

## 8. SAFETY STANDARDS

The drive complies with the following safety standards:

- (1) UL standard
- (2) CSA standard
- (3) TÜV standard
- (4) CE standard

## 9. FRONT INDICATOR

- (1) Location : Refer to Fig. 3.1-1.
- (2) Color : Green
- (3) Lighting conditions
  - (a) Continuous on
    - During seek
    - Transfer of the read data to the host is under way.
  - (b) Flashing with a period of 3 second (Duty 50%)
    - During write
    - While audio is being played
  - (c) Flashing with a period of 1 second (Duty 50%)
    - From POR or tray loading to the end of TOC read (when the disc is present)
    - From POR or tray loading to the end of detecting the disc (when the disc is not present). If an error which is considered to arise from the disc occurs, flashing continues until the disc is ejected. If an error which seems to rest with the drive's hardware, flashing continues until the power is switched OFF.

## 10. DRIVE CONFIGURATION

The setting to master or slave is determined by the CSEL signal (interface connector 47 pin).

If the signal is at low level, the drive is set to the master, and if it is open or at high level, it is set to the slave.

## 11. INTERFACE CONNECTOR

- (1) Connector on the drive : JAE KX15-50KLDLE or equivalent
- (2) Applicable connector on the host : JAE KX14-50K5D1 or equivalent
- (3) Pin assignment : Refer to Table 11-1, Fig. 11-1.

(Table 11-1) Interface connector pin assignment

No.	SIGNAL	No.	SIGNAL
1	LOUT	2	ROUT
3	AGND	4	N.C
5	-RESET	6	DD8
7	DD7	8	DD9
9	DD6	10	DD10
11	DD5	12	DD11
13	DD4	14	DD12
15	DD3	16	DD13
17	DD2	18	DD14
19	DD1	20	DD15
21	DD0	22	DMARQ
23	GROUND	24	-DIOR (-HDMARDY/HSTROBE)
25	-DIOW (STOP)	26	GROUND
27	IORDY (-DDMARDY/DSTROBE)	28	-DMACK
29	INTRQ	30	-IOCS16
31	DA1	32	-PDIAG (-CBLID)
33	DA0	34	DA2
35	-CS0	36	-CS1
37	-DASP	38	+5V
39	+5V	40	+5V
41	+5V	42	+5V
43	GROUND	44	GROUND
45	GROUND	46	GROUND
47	CSEL	48	GROUND
49	RESERVED	50	RESERVED

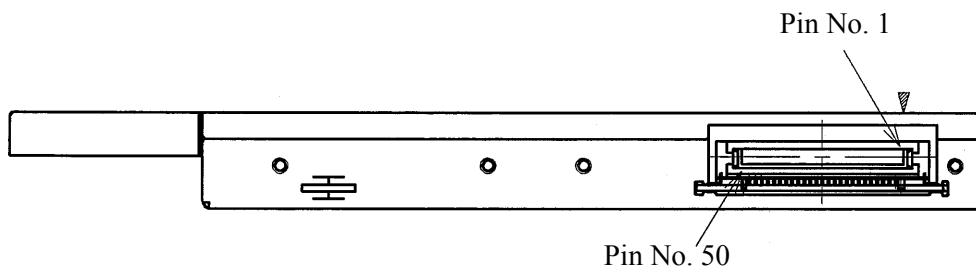

(Fig. 11-1) Interface connector assignment

## 12. AUDIO INTERFACE

- (1) LOUT : Line output of the left channel (unbalanced)
- (2) ROUT : Line output of the right channel (unbalanced)
- (3) AGND : Ground of audio line output.

For the electrical specification of the line output, refer to 5.2.

## 13. POWER INTERFACE

The following specifications apply to the interface connector terminals of the drive. The power should be supplied from a power supply unit with reinforced insulation or double insulation.

- (1) Allowable supply voltage range : +5VDC  $\pm$ 5% (4.75 to 5.25V)  
There should be no abnormal operations by DC +5V  $\pm$ 10%.
- (2) Allowable ripple voltage : 100mVp-p or less, 50 to 20MHz (including the spike noise)
- (3) Current consumption : Refer to Table 13-1.

**(Table 13-1) Current consumption**

Mode	Average current max (A)	Peak current max (A)
Standby/Sleep	0.025	
Write 24x	1.0	
Active	0.9	
Random access (Duty 100%)	1.2	1.5
During starting/seek		1.5
During eject		1.5

Remarks:

1. The supply voltage should be 5V+5%.
2. For each of the sleep, standby, and active modes, refer to "15. POWER MANAGEMENT SPECIFICATION".
3. Does not include pulse-like current below 1msec.

## 14. IDE HARDWARE INTERFACE

### 14.1 Outline

(1) Applicable standard

- ANSI standard : X3T13/1321D (ATA-5)
- SFFC : SFF-8020i Rev. 2.6 and SFF-8090v3

### 14.2 Electrical Characteristics

The following specifications apply to the interface connector terminal for the IDE signal of the drive. The input signals refer to the signals input to the drive whereas the output signals refer to the signals output from the drive.

(1) Tri-state input/output signals (DD0 to DD15, –PDIAG)

(a) Input signal level

- Low level : 0 to 0.8VDC
- High level : 2.0 to 5.25VDC
- Hysteresis : possessed
- Maximum input current :  $\pm 25\mu\text{A}$

(b) Output signal level

- Low level : 0 to 0.4VDC (output sink current 12mA)
- High level : 2.7 to 3.3VDC (output source current 1mA)
- Maximum output current at high impedance :  $\pm 25\mu\text{A}$

(c) Termination (DD0 to DD15)

- Pull-up resistance : Not equipped
- Series resistance :  $33\Omega$

(d) Termination (–PDIAG)

- Pull-up resistance :  $10\text{k}\Omega$
- Series resistance :  $0\Omega$

(2) Open drain input/output signals (–DASP)

(a) Input signal level

- Low level : 0 to 0.8VDC
- High level : 2.0 to 5.25VDC
- Hysteresis : possessed
- Maximum input current :  $\pm 25\mu\text{A}$  (excluding the pull-up resistance)

(b) Output signal level

- Low level : 0 to 0.4VDC (output sink current 12mA)
- Maximum output current at high impedance :  $\pm 25\mu\text{A}$

(c) Termination

- Pull-up resistance :  $10\text{k}\Omega$
- Series resistance :  $0\Omega$

(3) Tri-state output signals (DMARQ, INTRQ, IORDY)

- Low level : 0 to 0.4VDC (output sink current 12mA)
- High level : 2.7 to 3.3VDC (output source current 1mA)
- Maximum output current at high impedance :  $\pm 25\mu\text{A}$
- Series resistance :  $22\Omega$

- (4) Open-drain output signals (–IOCS16)
- Low level : 0 to 0.4VDC (output sink current 12mA)
  - Maximum output current at high impedance :  $\pm 25\mu\text{A}$
- (5) Input signals (–RESET, –DIOW, –DIOR, CSEL, –DMACK, DA0 to DA2, –CS0, –CS1)
- (a) Input signal level
- Low level : 0 to 0.8VDC
  - High level : 2.0 to 5.25VDC
  - Hysteresis (excluding RESET, CSEL) : possessed
  - Maximum input current :  $\pm 25\mu\text{A}$  (excluding the pull-up resistance)
  - Pull-up resistance
    - RESET : 10k $\Omega$
    - CSEL : 47k $\Omega$
  - Series resistance (–RESET, –DIOW, –DIOR, –DMACK, DA0 to DA2, –CS0, –CS1) : 82 $\Omega$

### 14.3 Input/Output Signals

Refer to Table 14.3-1.

Among the following signals, the input signal refers to the signal input to the CD-RW drive and the output signal refers to the signal output from the CD-RW drive and the input/output signal refers to the bidirectional signal.

**(Table 14.3-1) IDE Interface signal summary (Sheet 1 of 2)**

Signal	Description	Direction
CSEL	Cable select	IN
–CS0	Chip select0	IN
–CS1	Chip select1	IN
DD0	Data bus bit 0	IN/OUT
DD1	Data bus bit 1	IN/OUT
DD2	Data bus bit 2	IN/OUT
DD3	Data bus bit 3	IN/OUT
DD4	Data bus bit 4	IN/OUT
DD5	Data bus bit 5	IN/OUT
DD6	Data bus bit 6	IN/OUT
DD7	Data bus bit 7	IN/OUT
DD8	Data bus bit 8	IN/OUT
DD9	Data bus bit 9	IN/OUT
DD10	Data bus bit 10	IN/OUT
DD11	Data bus bit 11	IN/OUT
DD12	Data bus bit 12	IN/OUT
DD13	Data bus bit 13	IN/OUT
DD14	Data bus bit 14	IN/OUT
DD15	Data bus bit 15	IN/OUT
–DASP	Device active/Slave present	IN/OUT

(Table 14.3-1) IDE Interface signal summary (Sheet 2 of 2)

Signal	Description	Direction
DA0	Device address bit 0	IN
DA1	Device address bit 1	IN
DA2	Device address bit 2	IN
–DMACK	DMA acknowledge	IN
DMARQ	DMA request	OUT
INTRQ	Interrupt request	OUT
–IOCS16	Drive 16 bit I/O	OUT
–IOR	I/O read	IN
–HDMARDY	DMA ready during Ultra DMA data in bursts	IN
HSTROBE	Data strobe during Ultra DMA data out bursts	IN
IORDY	I/O ready	OUT
–DDMARDY	DMA ready during Ultra DMA data out bursts	OUT
DSTROBE	Data strobe during Ultra DMA data in bursts	OUT
–DIOW	I/O write	IN
STOP	Stop during Ultra DMA data bursts	IN
–PDIAG	Passed diagnostics	IN/OUT
–CBLID	Cable assembly type identifier	–
–RESET	Reset	IN

#### 14.4 Interface Timing

The following specifications all apply to the signal interface connector terminal of the CD-ROM drive. In timing description, H indicates high level (false) and L low level (true).

- (1) Reset timing (master/slave) : Fig. 14.4-1
- (2) Reset timing (slave) : Fig. 14.4-2
- (3) PIO write cycle timing : Fig. 14.4-3
- (4) PIO read cycle timing : Fig. 14.4-4
- (5) DMA single word transfer timing : Fig. 14.4-5
- (6) DMA multi word transfer timing : Fig. 14.4-6
- (7) Ultra DMA transfer timing (Data in burst) : Fig. 14.4-7
- (8) Ultra DMA transfer timing (Data out burst): Fig. 14.4-8

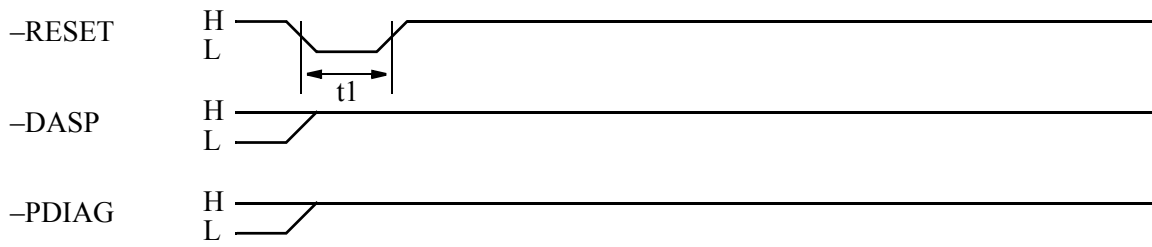

Symbol	Item	Min	Typ	Max	Unit
t1	-HRST pulse width	25			μs

(Fig. 14.4-1) Reset timing (master)

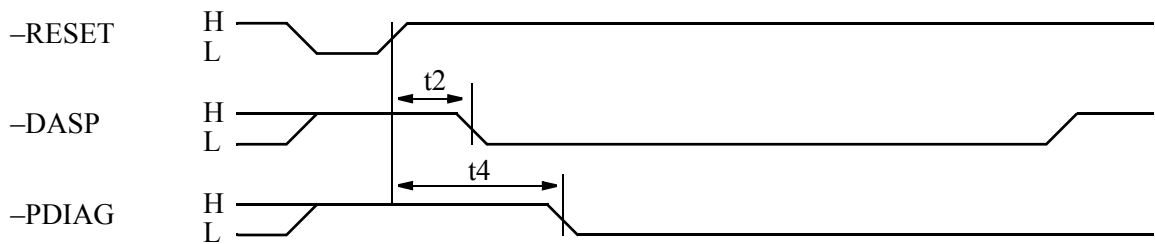

Symbol	Item	Min	Typ	Max	Unit
t2	-DASP assert time		70	400	ms
t4	-PDIAG assert start		0.2	30	s

(Fig. 14.4-2) Reset timing (slave)

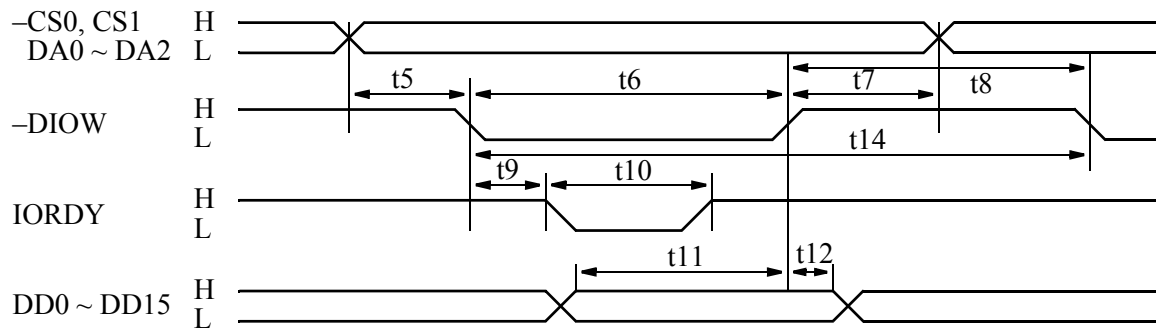

Symbol	Item	Min	Max	Unit
t5	Address setup time	25		ns
t6	$\overline{\text{IOW}}$ pulse width	70		ns
t7	Address hold time	10		ns
t8	$\overline{\text{IOW}}$ interactive pulse width	25		ns
t9	IORDY delay time		35	ns
t10	IORDY pulse width		1,250	ns
t11	Write data setup time	20		ns
t12	Write data hold time	10		ns
t14	Write cycle time	120		ns

(Fig. 14.4-3) PIO write cycle timing

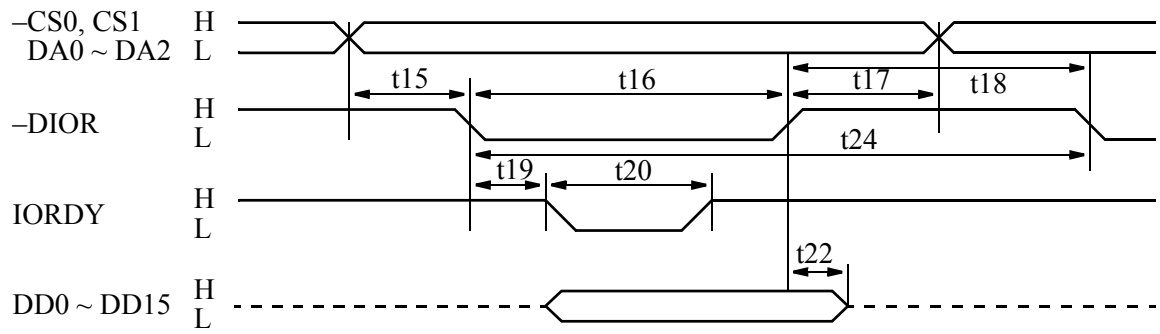

Symbol	Item	Min	Max	Unit
t15	Address setup time	25		ns
t16	-DIOR pulse width	70		ns
t17	Address hold time	10		ns
t18	-DIOR interactive pulse width	25		ns
t19	IORDY delay time		35	ns
t20	IORDY pulse width	90	1,250	ns
t22	Read data hold time	5		ns
t24	Read cycle time	120		ns

(Fig. 14.4-4) PIO read cycle timing

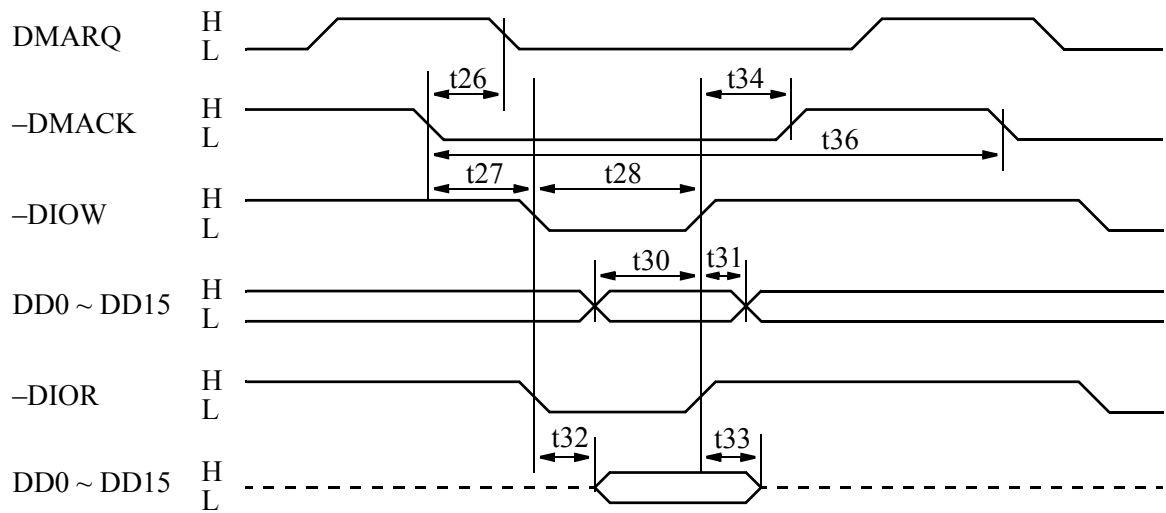

Symbol	Item	Min	Max	Unit
t26	From -DMACK assert to -DMAREQ negate		80	ns
t27	From -DMACK assert to -DIOW low	0		ns
t28	-DIOW, -DIOR pulse width	120		ns
t30	Write data setup time	35		ns
t31	Write data hold time	20		ns
t32	Read data delay time		60	ns
t33	Read data hold time	5		ns
t34	From -DIOW, -DIOR high to -DMACK negate	0		ns
t36	Cycle time	240		ns

(Fig. 14.4-5) DMA single word transfer timing

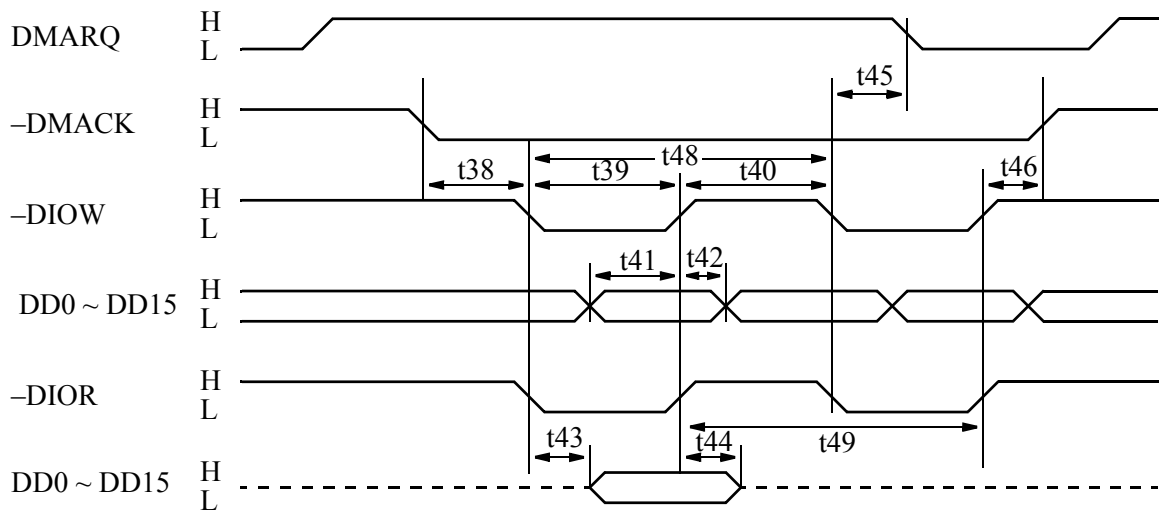

Symbol	Item	Min	Max	Unit
t38	From -DMACK assert to -DIOW low	0		ns
t39	-DIOW, -DIOR pulse width	70		ns
t40	-DIOW, -DIOR interactive pulse width	25		ns
t41	Write data setup time	20		ns
t42	Write data hold time	10		ns
t43	Read data delay time		50	ns
t44	Read data hold time	5		ns
t45	From -DIOW, -DIOR low to DMARQ negate		35	ns
t46	From -DIOW, -DIOR high to -DMACK negate	5		ns
t48	Write cycle time	120		ns
t49	Read cycle time	120		ns

(Fig. 14.4-6) DMA multi word transfer timing

**Initiating an Ultra DMA data in burst**

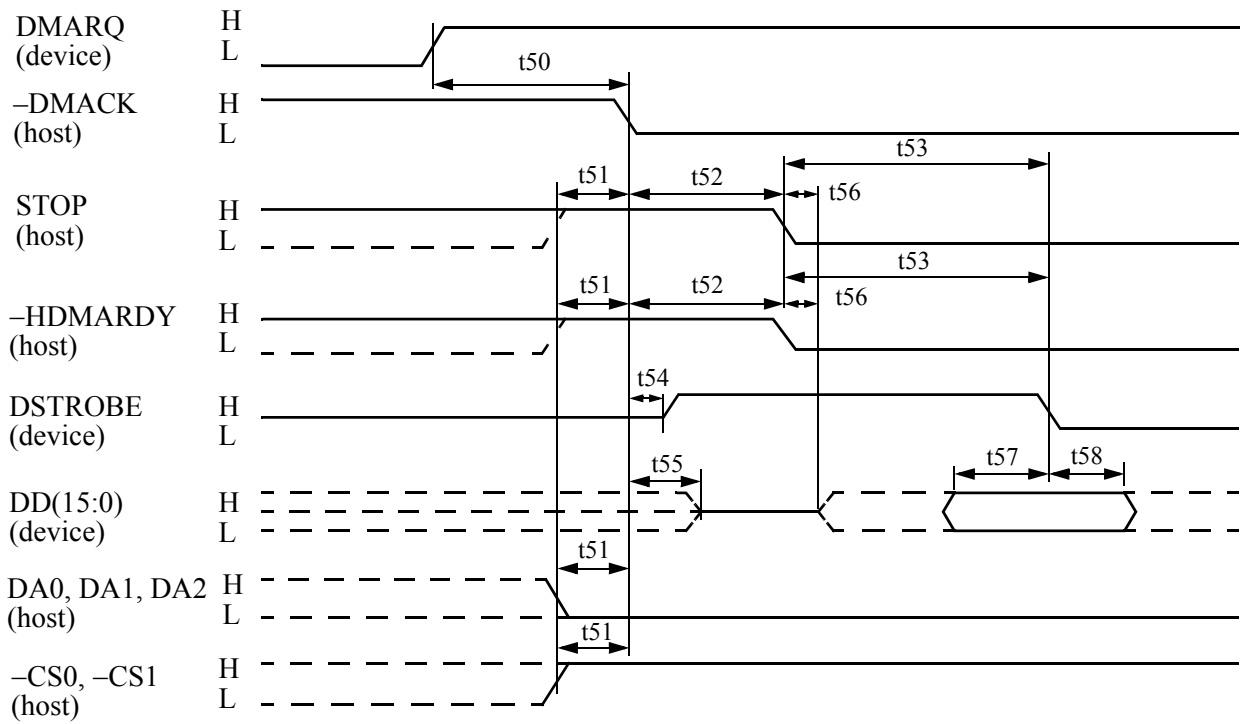

**Sustained Ultra DMA data in burst**

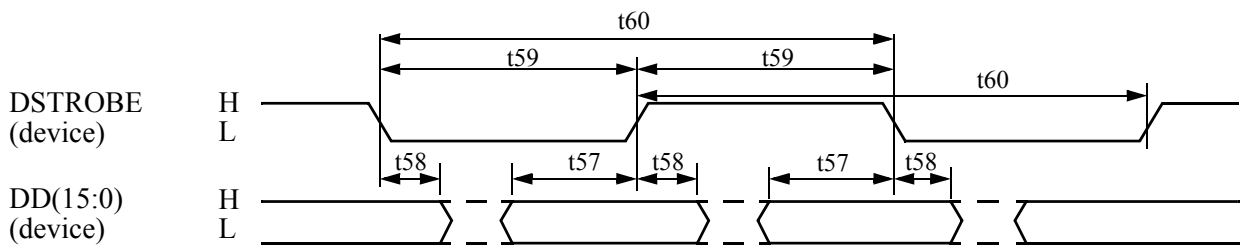

**Host pausing an Ultra DMA data in burst**

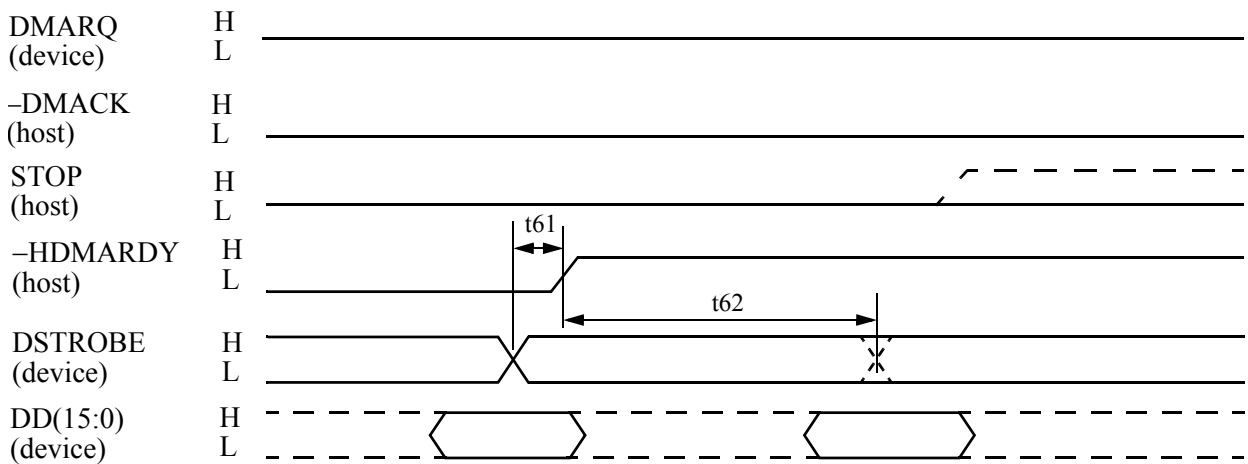

**(Fig. 14.4-7) Ultra DMA transfer timing (Data in burst) (Fig. 1 of 3)**

**Device terminating an Ultra DMA data in burst**

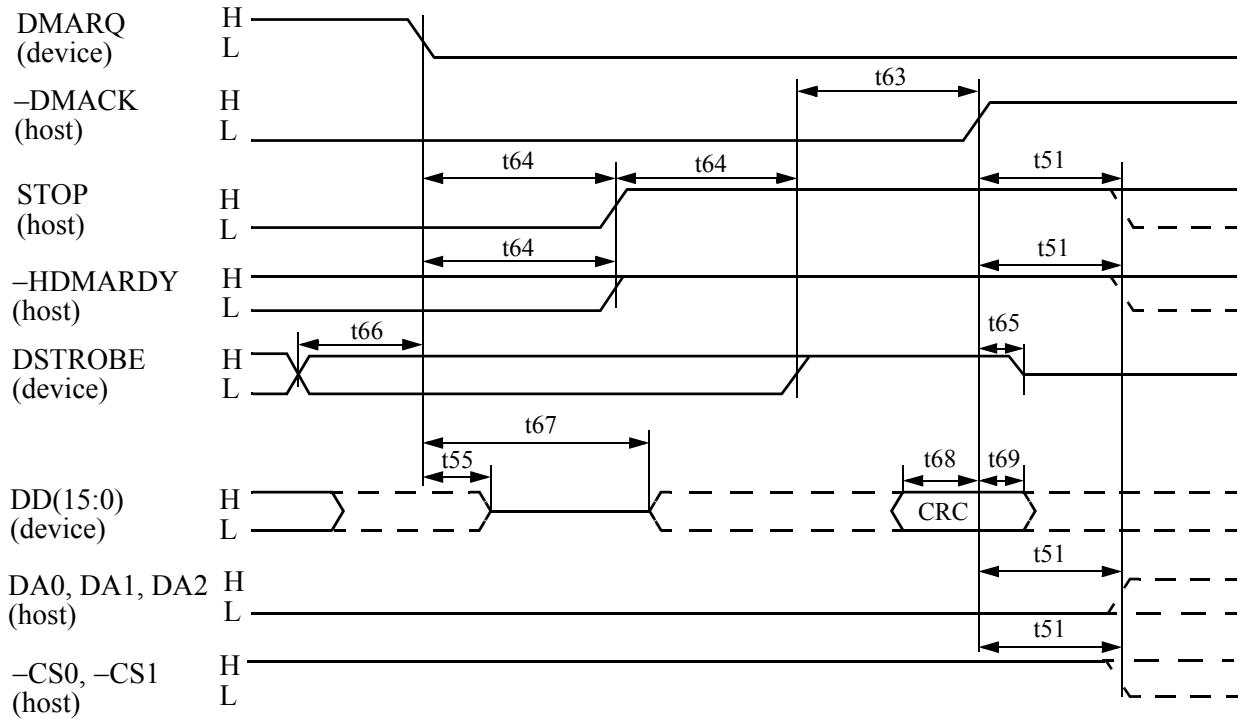

**Host terminating an Ultra DMA data in burst**

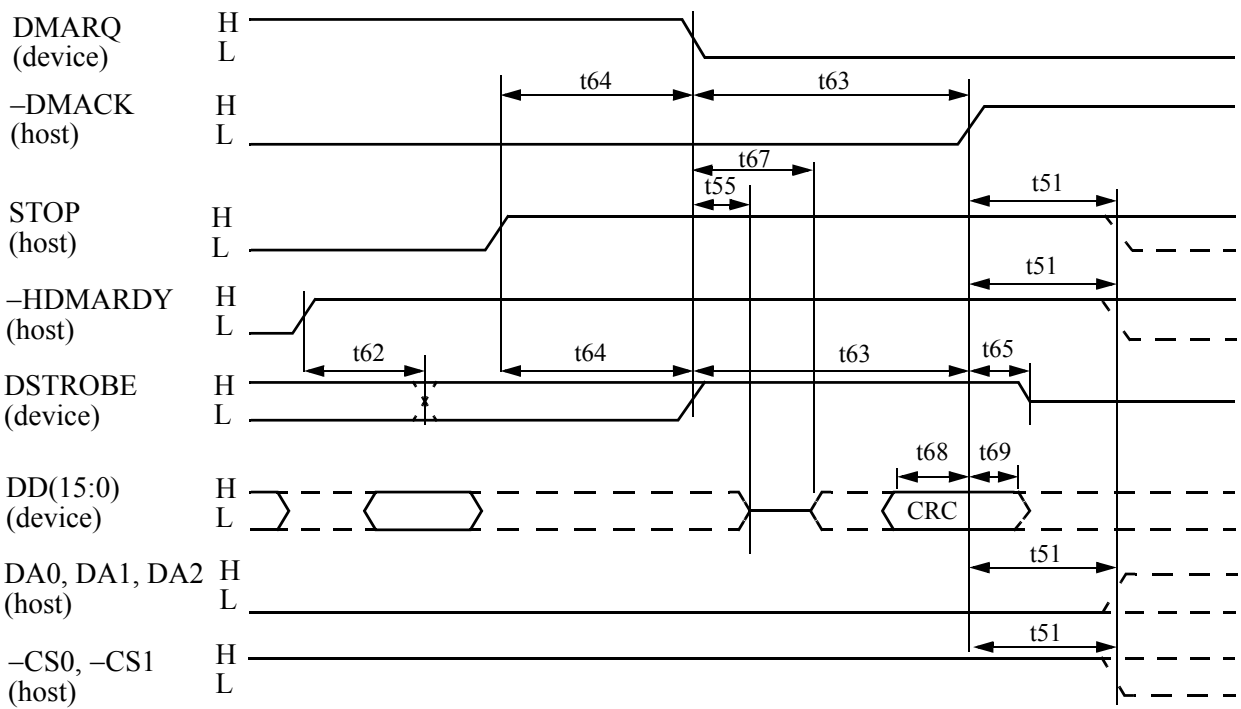

**(Fig.14.4-7) Ultra DMA transfer timing (Data in burst) (Fig. 2 of 3)**

Symbol	Item	Min	Max	Unit	
t50	Unlimited interlock time	0		ns	
t51	Setup time/Hold time (to $\text{-DMACK} \downarrow$ )	20		ns	
t52	Envelope time ( $\text{-DMACK} \downarrow$ to STOP/ $\text{-HDMARDY} \downarrow$ )	20	70	ns	
t53	DSTROSE negate start time (STOP/ $\text{-HDMARDY} \downarrow$ $\downarrow$ to DSTROBE $\downarrow$ )	0	170	ns	
t54	DSTROBE drive delay time (to $\text{-DMACK} \downarrow$ )	0		ns	
t55	Output data, release delay time (to $\text{-DMACK} \downarrow$ )		10	ns	
t56	Output data, drive start time (to STOP $\downarrow$ / $\text{-HDMARDY} \downarrow$ )	0		ns	
t57	Valid data, setup time (to DSTROBE edge)	30		ns	
t58	Valid data, hold time (to DSTROBE edge)	6		ns	
t59	DSTROBE cycle time	Mode 2	54	ns	
		Mode 1	73	ns	
		Mode 0	112	ns	
t60	DSTROBE x 2-cycle time	Mode 2	115	ns	
		Mode 1	154	ns	
		Mode 0	230	ns	
	DSTROBE Average x 2-cycle time	Mode 2	120	ns	
		Mode 1	160	ns	
		Mode 0	240	ns	
t61	DSTROBE stop shift time (DSTROBE edge to $\text{-HDMARDY} \uparrow$ )	Mode 2		20	ns
		Mode 1		30	ns
		Mode 0		50	ns
t62	Final DSTROBE stop time (to $\text{-HDMARDY} \uparrow$ )		60	ns	
t63	DSTROBE $\uparrow$ to $\text{-DMACK} \uparrow$ delay time	20		ns	
t64	Limited interlock time	0	150	ns	
t65	DSTROBE release time (to $\text{-DMACK} \uparrow$ )		20	ns	
t66	DSTROBE edge to HDMARQ $\downarrow$ delay time	50		ns	
t67	HDMARQ $\downarrow$ to CRC data output delay time	20		ns	
t68	Data setup time (to $\text{-DMACK} \uparrow$ )	30		ns	
t69	Data hold time (to $\text{-DMACK} \uparrow$ )	6		ns	

**(Fig.14.4-7) Ultra DMA transfer timing (Data in burst) (Fig. 3 of 3)**

**Initiating an Ultra DMA data out burst**

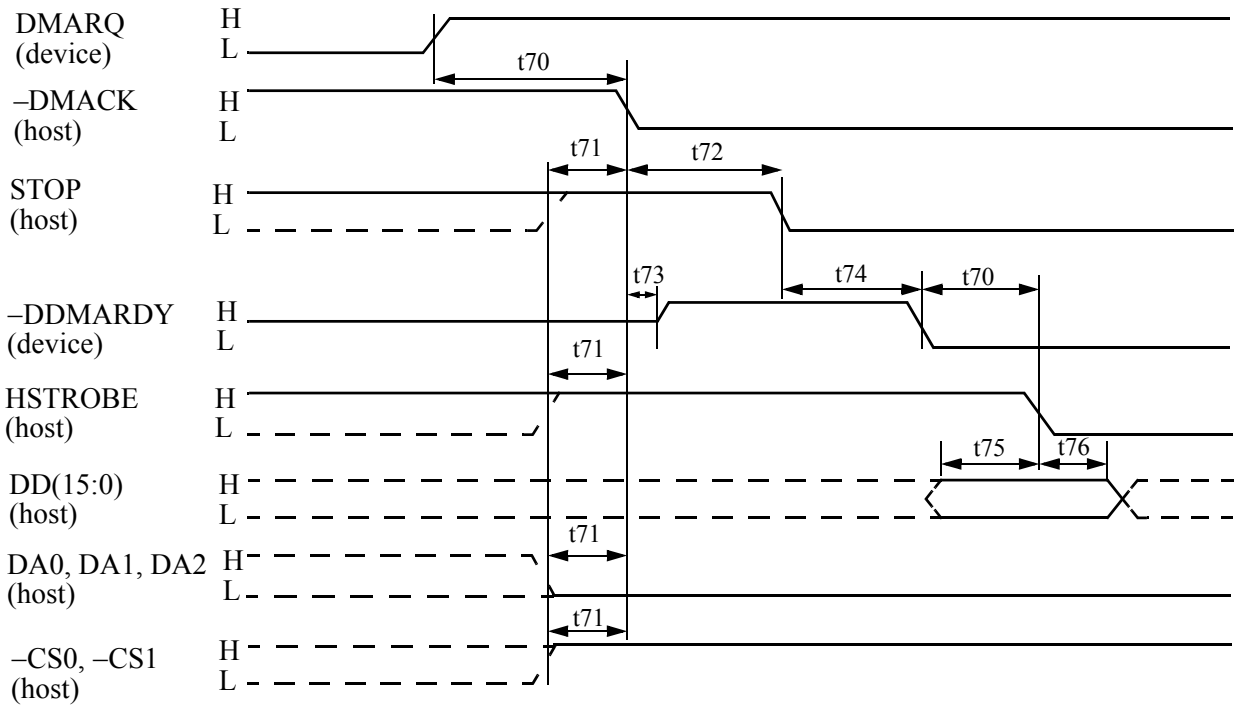

**Sustained Ultra DMA data out burst**

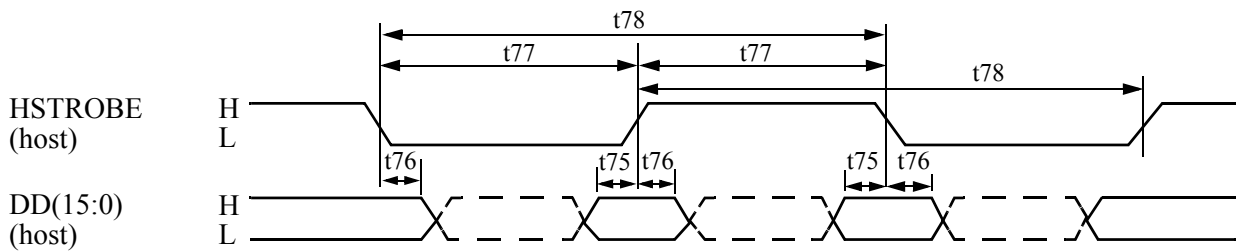

**Device pausing an Ultra DMA data out burst**

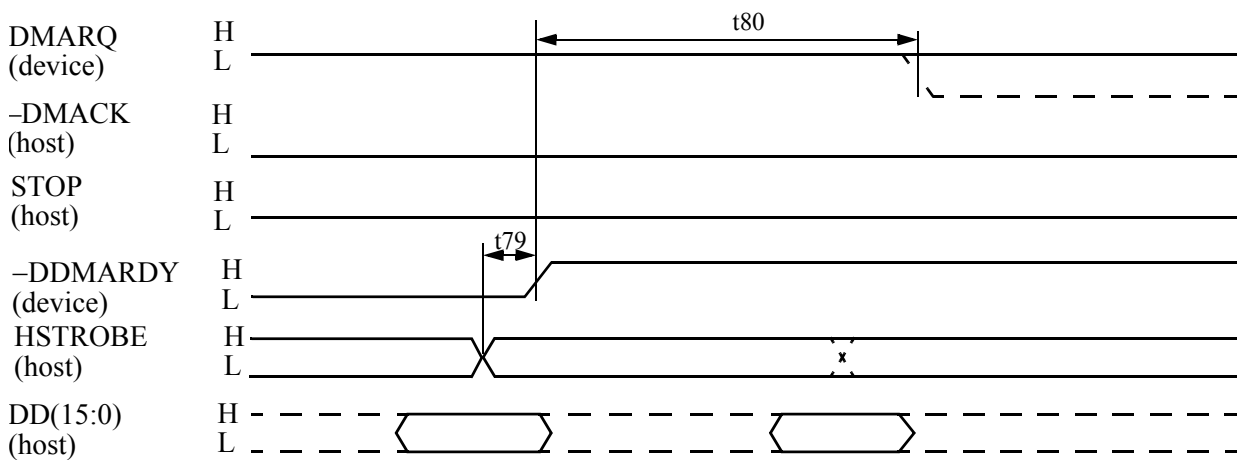

**(Fig. 14.4-8) Ultra DMA transfer timing (Data out burst) (Fig. 1 of 3)**

**Host terminating an Ultra DMA data out burst**

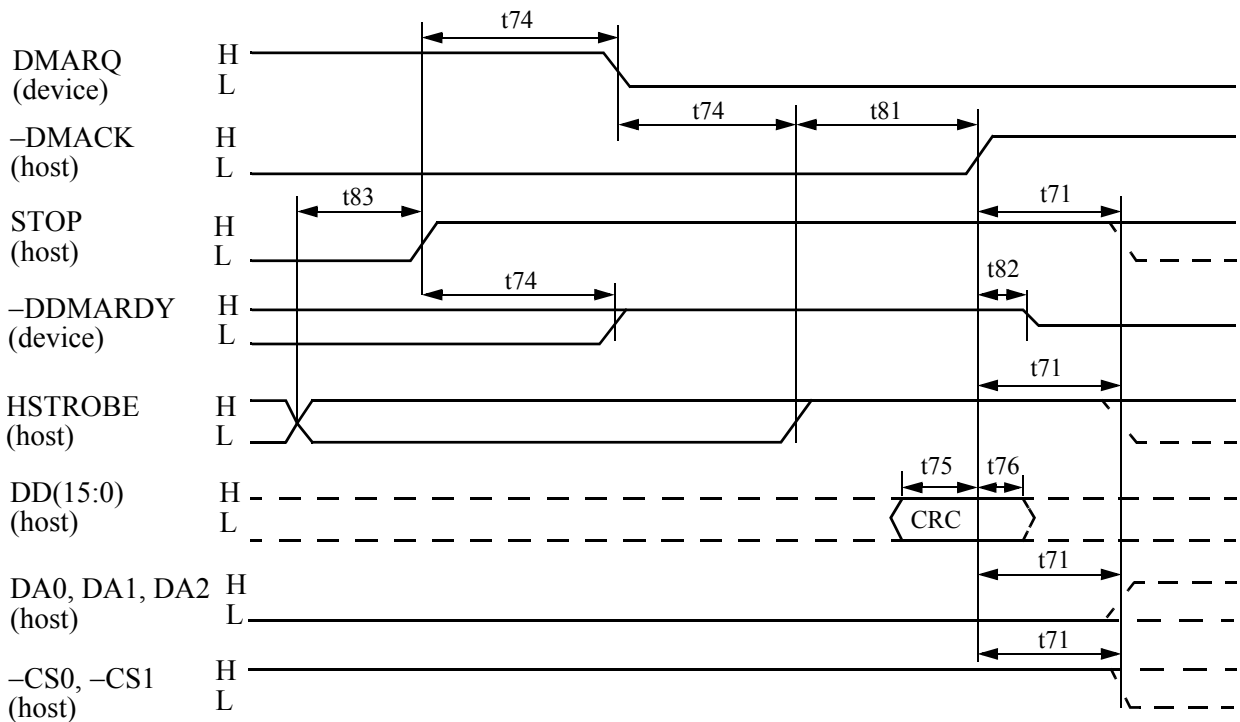

**Device terminating an Ultra DMA data**

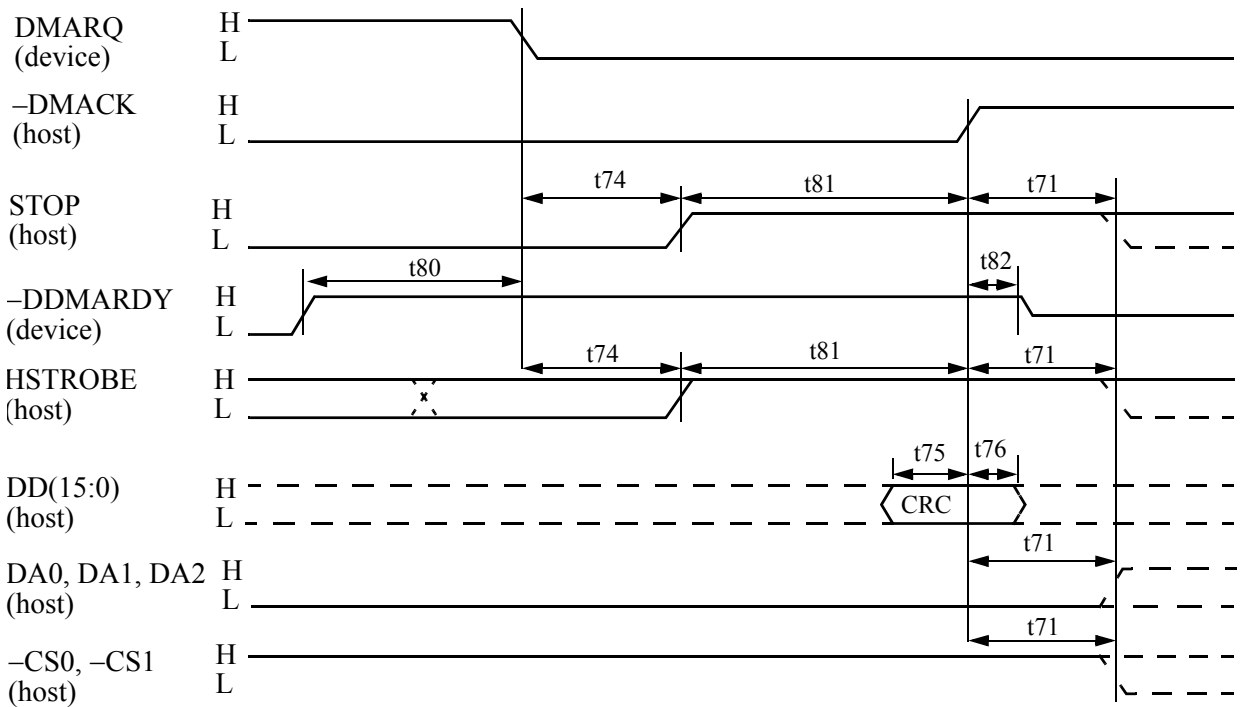

**(Fig.14.4-8) Ultra DMA transfer timing (Data out burst) (Fig. 2 of 3)**

Symbol	Item	Min	Max	Unit	
t70	Unlimited interlock time	0		ns	
t71	Setup time/Hold time (to -DMACK ↓)	20		ns	
t72	Envelope time(-DMACK ↓ to STOP ↓)	20	70	ns	
t73	-DDMARDY drive delay time (to -DMACK ↓)	0		ns	
t74	Limited interlock time	0	150	ns	
t75	Data setup time (to -HSTROBE edge/to -DMACK ↑)	7		ns	
t76	Data hold time (to HSTORE edge/ to -DMACK ↑)	5		ns	
t77	HSTORE cycle time	Mode 2	54	ns	
		Mode 1	73	ns	
		Mode 0	112	ns	
t78	HSTROBE x 2-cycle time	Mode 2	115	ns	
		Mode 1	154	ns	
		Mode 0	230	ns	
	HSTROBE Average x 2-cycle time	Mode 2	120	ns	
		Mode 1	160	ns	
		Mode 0	240	ns	
t79	Receipt stop shift time (HSTROBE edge to -DDMARDY ↑)	Mode 2		20	ns
		Mode 1		30	ns
		Mode 0		50	ns
t80	-DDMARDY ↑ to DMARQ ↓ delay time	100		ns	
t81	HSTROBE ↑ to -DMACK ↑ delay time	20		ns	
t82	-DDMARDY release time (to -DMACK ↑)		20	ns	
t83	-HSTROBE edge to STOP ↑ delay time	50		ns	

**(Fig.14.4-8) Ultra DMA transfer timing (Data out burst) (Fig. 3 of 3)**

## 14.5 COMMAND SET

### 14.5.1 ATA COMMAND

Refer to table 14.5.1-1.

(Table 14.5.1-1) ATA COMMAND

CODE	COMMAND
08	ATAPI SOFT RESET
E5	CHECK POWER MODE
90	EXECUTE DRIVE DIAGNOSTIC
E3	IDLE
E1	IDLE IMMEDIATE
00	NOP
A0	ATAPI PKT.
A1	ATAPI IDENTIFY DEVICE
EF	SET FEATURE
E6	SLEEP
E2	STANDBY
E0	STANDBY IMMEDIATE
A2	SERVICE

## 14.5.2 ATAPI COMMAND

Refer to table 14.5.2-1.

(Table 14.5.2-1) List of the ATAPI commands (Sheet 1 of 2)

CODE	COMMAND
A1	BLANK
5B	CLOSE TRACK/SESSION
04	FORMAT UNIT
4A	GET EVENT STATUS NOTIFICATION
12	INQUIRY
BD	MECHANISM STATUS
55	MODE SELECT
5A	MODE SENSE
4B	PAUSE/RESUME
45	PLAY AUDIO (10)
A5	PLAY AUDIO (12)
47	PLAY AUDIO MSF
49	PLAY TRACK RELATIVE (10)
A9	PLAY TRACK RELATIVE (12)
1E	PREVENT/ALLOW MEDIUM REMOVAL
28	READ (10)
A8	READ (12)
5C	READ BUFFER CAPACITY
25	READ CD/DVD CAPACITY
BE	READ CD
B9	READ CD MSF
51	READ DISC INFORMATION
44	READ HEADER
42	READ SUB-CHANNEL
43	READ TOC
52	READ TRACK/RZONE INFORMATION
03	REQUEST SENSE
53	RESERVE TRACK
01	REZERO UNIT
BA	SCAN
2B	SEEK
5D	SEND CUE SHEET
54	SEND OPC INFORMATION
BB	SET CD-ROM SPEED
1B	START/STOP UNIT
4E	STOP PLAY/SCAN
35	SYNCHRONIZE CACHE

(Table 14.5.2-1) List of the ATAPI commands (Sheet 2 of 2)

CODE	COMMAND
00	TEST UNIT READY
2A	WRITE (10)
AA	WRITE (12)
AD	READ DVD STRUCTURE
23	READ FORMATTED CAPACITIES
A4	REPORT KEY
A3	SEND KEY
A7	SET READ AHEAD
46	GET CONFIGURATION
AC	GET PERFORMANCE
A2	SEND EVENT

## 15. POWER MANAGEMENT SPECIFICATION

This drive has a power management function to reduce power consumption.

### 15.1 Power Management Modes

The drive has the following four power management modes. The transition between these modes is performed by the timer within the drive or a command issued by the host.

- Active mode
- Idle mode
- Standby mode
- Sleep mode

#### 15.1.1 Transition in power management mode

The transition in the power management mode is shown in Fig. 15.1.1-1.

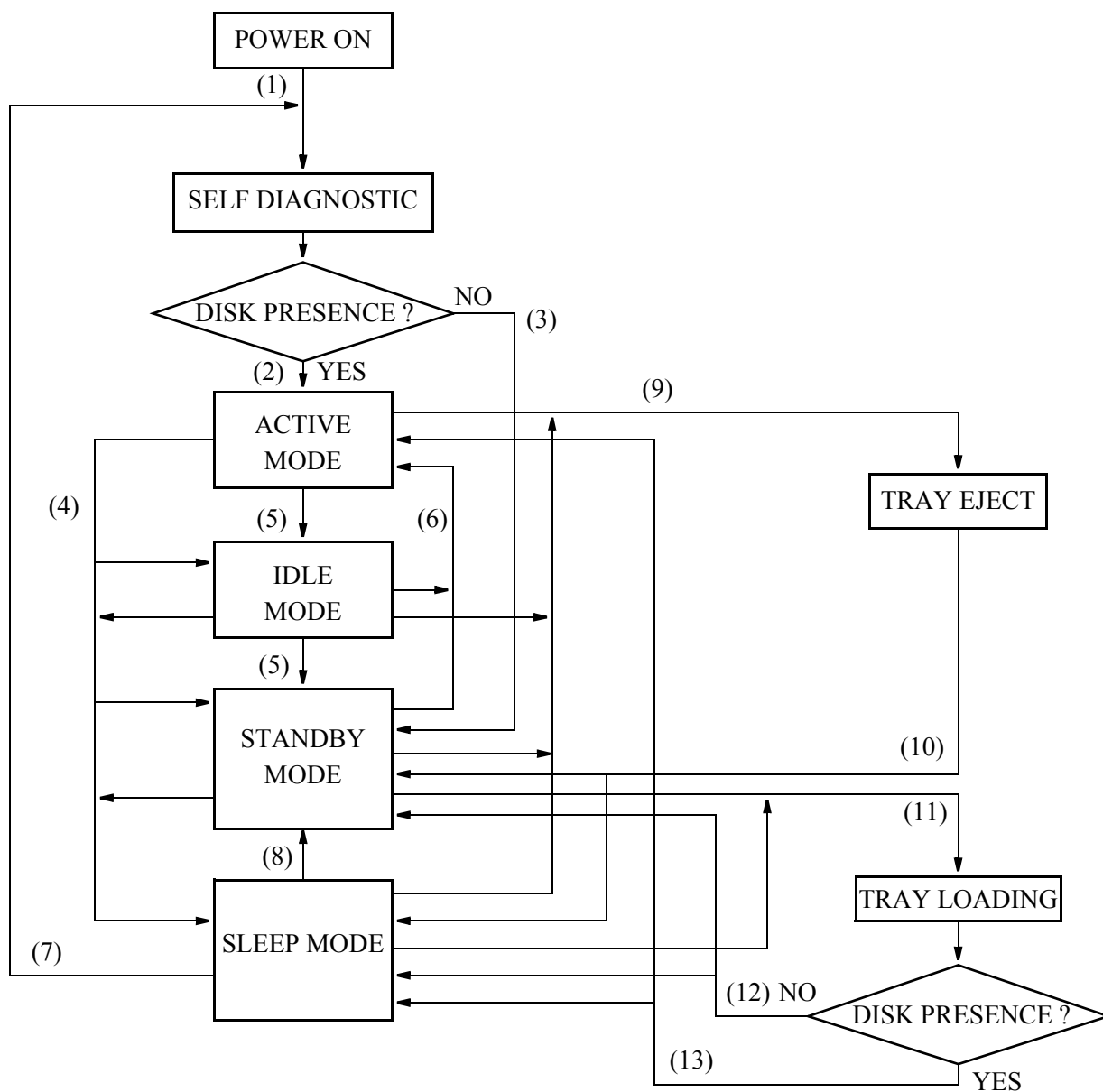

(Fig. 15.1.1-1) Transition in power management mode

- (1) When the RESET signal is released, the disc detection is performed after self-diagnostics are completed.
- (2) If the disc is loaded, the mode will switch to the active mode and starting operation will begin.
- (3) If the disc is not loaded, the mode will switch to the standby mode.
- (4) Using the power management command (IDLE, IDLE IMMEDIATE, STANDBY, STANDBY IMMEDIATE, SLEEP), the transition from the active mode to the idle, standby or sleep mode, from the idle mode to the standby or sleep mode, or from the standby mode to the idle or sleep mode is possible.
- (5) The transition from the active mode to the idle mode or from the idle mode to the standby mode is also performed by the timer the has. The timer will be initialized to the specified value when disc detection operation is under way or when a command which requires disc access is executed. The timer will not be initialized when a command which does not require disc access is executed in the active mode.
- (6) The resumption from the idle or standby mode to the active mode is initiated when a command which requires disc access is executed.
- (7) The resumption after the sleep mode is possible only after the RESET signal, the SRST (bit 2 of the DEVICE Control Register) or the ATAPI SOFT RESET command is detected. If resumption after the sleep mode is initiated using the RESET signal, an operation similar to when the power is switched ON occurs.
- (8) If resumption after the sleep mode is initiated using the SRST or the ATAPI SOFT RESET command, the drive enters the standby mode.
- (9) Tray ejection in each of the active, idle, standby and sleep modes is possible.
- (10) If the tray is ejected in the active, idle or standby mode, the drive enters the standby mode when the tray is out or the sleep mode when the tray is ejected in the sleep mode.
- (11) If the tray is inserted when the tray is out, the disc detection operation is performed.
- (12) If no disc is loaded, the drive will resume a mode when the tray is out.
- (13) If the disc is loaded, the drive will resume the active mode. However, the drive resumes the sleep mode following the TOC read only when the tray is ejected in the sleep mode.

## 15.2 Active Mode

A state in which the drive is capable of responding in the shortest possible time to an access using a command, and all the electrical circuitry of the drive, the pickup, spindle motor and sled motor are operating. In the following cases, the drive will enter the active mode:

- (1) While it is being booted after the power is switched ON and self diagnosis is under way.
- (2) While the booting operation or Reading of the TOC is under way when the tray is inserted and the disc is loaded.
- (3) While the booting operation or Reading of the TOC is in progress with the power ON and the disc loaded.
- (4) While an command that requires disc access is being executed.
- (5) Until the drive switches over to other power management mode using the timer in the drive or the command after either (2), (3) or (4) above is performed.

## 15.3 Idle Mode

The idle mode has the same operational functions as the active mode. However, the current consumption is reduced by lowering the rotational speed of the spindle motor in the idle mode.

The transition to the idle mode comes in the following two ways:

- (1) When using the timer in the drive:
 

After executing (2), (3) and (4) in 14.2, if the specified time elapses by the timer in the drive, the mode will switch from the active mode to the idle mode.

The specified time of the timer is set to 8 seconds.
- (2) When using the power management command (IDLE, IDLE IMMEDIATE):

The transition from the active or standby mode is possible using the power management command (IDLE, IDLE IMMEDIATE).

For details, refer to the Software Specification.

## 15.4 Standby Mode

Except for the functions required for the reception of a command, all other functions are in the power save condition. And although the command can be received, a time is required to restore the functions that are in the power save condition for the command that requires disc access. The transition to the standby mode comes in the following three ways:

- (1) When using the timer in the drive:

After executing (2), (3) and (4) in 15.2, if the specified time elapses by the timer in the drive, the mode will switch from the active to the standby mode via the idle mode.

Although the specified time of the timer can be preset using the STANDBY command or MODE SELECT command, it is set to 32 seconds by default. The transition time to the idle mode is included in the preset value of the timer.

For details, refer to the Software Specification. The timer will be initialized to the specified value after executing (2), (3) and (4) in 15.2. The timer will not be initialized when a command which does not require disc access is executed in the active mode.

- (2) When using the power management command (STANDBY, STANDBY IMMEDIATE) or START/STOP UNIT command:

The transition from the active or idle mode is possible using the power management command (STANDBY, STANDBY IMMEDIATE) or START/STOP UNIT command.

For details, refer to the Software Specification.

- (3) When the power is switched ON or a disc is not detected by the disc detection operation while the tray is being retracted, the drive will enter the standby mode.

## 15.5 Sleep Mode

The drive enters a state in which all functions are stopped and no command can be received.

The transition to the sleep mode is possible using the SLEEP command.

For details, refer to the Software Specification. The resumption from the sleep mode is possible using the RESET signal, the SRST (bit 2 of the Device Control Register) or the ATAPI SOFT RESET command.

### 15.5.1 Tray ejection/insertion in the sleep mode

If the eject button is pressed in sleep mode, the tray will be ejected before sleep mode is entered. If the tray is inserted while in this state, disc detection is performed; If the disc is loaded on the tray, the start-up operation is performed before sleep mode is entered. If the disc is not loaded on the tray, sleep mode is entered.

## 16. OTHERS

### 16.1 Using the lens cleaner

Some commercially available wet-type lens cleaners may sometimes actually make the lens dirtier rather than cleaning it. In general, we recommend that you avoid using a wet-type lens cleaner.

Use a dry-type lens cleaner.

## 16.2 Safety of Laser Products

When selling this unit or a system with this unit to an end user, print the following text in the instruction manual or enclose the separate sheet on which the following text is printed with the instruction manual.

This product has been designed and manufactured according to FDA regulations "title 21. CFR. chapter1, subchapter J. based on the radiation Control for Health and Safety Act of 1968", and is classified as a class 1 laser product. There is no hazardous invisible laser radiation during operation because invisible laser radiation emitted inside of this product is completely confined in the protective housings.

The label required in this regulation is shown bellow.

### CAUTION

Use of controls or adjustments or performance of procedures other than those specified herein may result in hazardous radiation exposure.

### Optical pickup

Type	: HOP-6201T
Manufacturer	: Hitachi Media Electronics Co., Ltd.
Laser output	: Less than 1.4mW (Play) and 75mW (Record) on the objective lens
Wavelength	: 777-787nm (CD) 645-664nm (DVD)
Standard	: IEC60825-1 : 2001

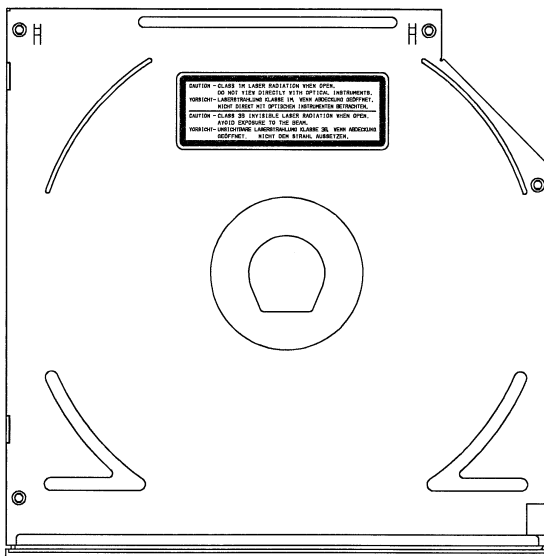

CAUTION - CLASS 1M LASER RADIATION WHEN OPEN.  
DO NOT VIEW DIRECTLY WITH OPTICAL INSTRUMENTS.  
VORSICHT- LASERSTRAHLUNG KLASSE 1M, WENN ABDECKUNG GEÖFFNET.  
NICHT DIREKT MIT OPTISCHEN INSTRUMENTEN BETRACHTEN.

CAUTION - CLASS 3B INVISIBLE LASER RADIATION WHEN OPEN.  
AVOID EXPOSURE TO THE BEAM.  
VORSICHT- UNSICHTBARE LASERSTRAHLUNG KLASSE 3B, WENN ABDECKUNG  
GEÖFFNET. NICHT DEM STRAHL AUSSETZEN.

(Fig. 16.2-1)