

AOM-5721

Qualcomm QCS6490 AI-on-Module Nano

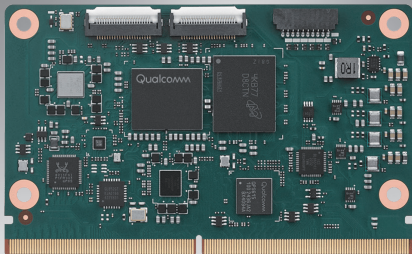

Features

- Kryo 670 CPU built on Arm v8 Cortex technology
- Adreno 643 GPU at 812 MHz
- Onboard LPDDR5 8GB, 6400MT/s memory
- 1 x 4 lane MIPI DSI, 1x DP and 1x eDP1.4 for Displays
- 3 x MIPI CSI 4-lane, 1 x MIPI CSI 2-lane
- 1 x USB3.2 Gen1, 5 x USB2.0, 4 x UART, 3 x I2C, 14 x GPIO, 3 x PCIe3.0
- 1 x UFS, 1 x 4-bit SDIO for storages
- Support Yocto, Ubuntu, Windows 11 IoT and Android



Introduction

Advantech AOM-5721 AI-on-Module is powered by Qualcomm QCS6490/5430 SoC which includes up to Arm v8 Cortex® in combination with Andreo GPU 643 and Andreo VPU 633 graphics engine. It provides PCIe, USB 3.2, Giga Ethernet, MIPI-CSI, I2C, SPI, GPIO, PWM, eDP, MIPI-DSI display for embedded applications.

AOM-5721 is paired with Advantech AOM carrier board for faster end product peripheral integration and time-to-market. The reference schematics and layout checklists documentations for carrier board development will be provided along with Windows 11 and Ubuntu, test utilities, hardware design utilities and reference drivers.

Specifications

Form Factor	Form Factor	AOM Nano (SMARC compatible)
Processor System	CPU	QCS6490 QCS5430
	Core	8x Kryo 670 CPU from 1.9 up to 2.7 GHz Up to 8x Kryo 670 CPU from 1.8 up to 2.1 GHz
Memory	Technology	LPDDR5 6400MT/s
	Capacity	Up to 16GB LPDDR5 (On-board)
	Flash	Up to 128GB UFS (Optional for EMMC) Up to 128GB UFS (Optional for EMMC)
Graphics	LVDS/MIPI DSI	1 x 4 lane MIPI DSI (Optional instead of HDMI) (4K30)(Mutually Exclusive)
	eDP	1 x eDP (1080P60)(Mutually Exclusive)
	DP	1 x DP(4K30)
	GPU	Adreno GPU 643 @812 MHz, Support for Open GL ES 3.2, Vulkan 1.x, DX FL 12 Adreno 642L GPU @ 550 MHz, Support for Open GL ES 3.2, Open CL 2.0, Vulkan 1.x, DX FL 12
VPU	Adreno VPU 633, Up to 4K60 decode for H.264/H.265/VP9, Up to 4K30 encode for H.264/H.265; Support for HDR10 and HDR10+ playback	
Ethernet	Chipset	RTL8211FSI
	Speed	2 x 10/100/1000 Mbps
RTC		Yes
Security		Qualcomm® Trusted Execution Environment (TEE) v5.3, TPM
I/O	PCIe	1 x PCIe Gen 3 x2(QPS615), 1 x PCIe Gen 3 x1(QPS615), 1 x PCIe Gen3 x1
	USB	1 x USB 3.2 Gen 1, 4 x USB 2.0, 1 x USB 2.0 (Recovery)
	Audio	1 x I2S
	SDIO	1
	Serial Port	2 x UART with TX/RX (Data Only), 2 x UART with TX/RX/RTS/CTS (2 wire handshake)
	SPI	2
	GPIO	14
	I2C	5 (I2C_GP, I2C_LCD, I2C_PM, I2C_CAM1, I2C_CAM0)
	CAN-FD	2
	Camera Input	1 x MIPI CSI 4-lane, 1 x MIPI CSI 2-lane (SMARC Edge Connector), 2 x MIPI CSI 4-lane (Connector)
PWM	1	
Power	Power Supply Voltage	Fixed 5V DC source
	Power Consumption	TBD
Environment	Storage Temperature	-40° to 85°C
	Standard Temperature	0° to 60°C (non-condensing) with 0.7m/s air flow
	Extend Temperature	-20° to 70°C (non-condensing) with 0.7m/s air flow
	Operating Humidity	95% @ 40°C (non-condensing)
	Non-Operating Humidity	95% @ 60°C (non-condensing)
Mechanical	Dimensions (W x D)	82 x 50 mm
Operating System		Yocto Linux, Ubuntu Linux, Windows 11 IoT, Android
Certifications		CE/FCC Class B

Block Diagram

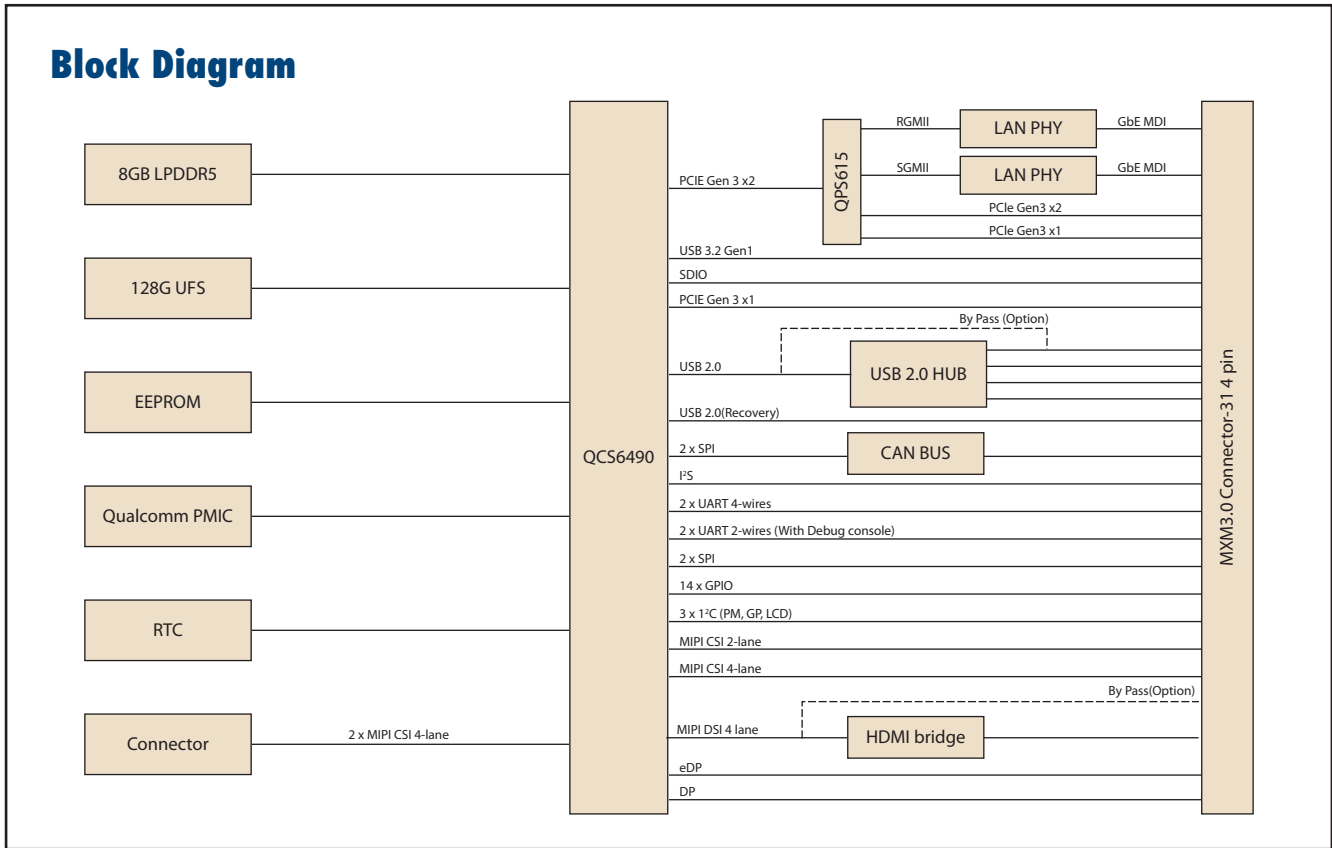

Ordering Information

Part No.	CPU	Memory	Flash Memory	UART	GbE	USB3.2 Gen1	USB 2.0	Display	I2S	I2C	CAN	Operating Temperature
AOM-5721B0-649AA1	QCS6490	8G	128G UFS	4	2	1	5	1 x DP +1 x HDMI (or 1 x DP + 1 x eDP)	1	3	2	-20°C ~ 70°C
AOM-5721C0-649AA1	QCS6490	8G	128G UFS	4	2	1	5	1 x DP +1 x HDMI (or 1 x DP + 1 x eDP)	1	3	2	0°C ~ 60°C
AOM-5721B0-543AA1	QCS5430	4G	64G eMMC	4	2	1	5	1 x DP +1 x 4 lane MIPI DSI (or 1 x DP + 1 x eDP)	1	3	2	-20°C ~ 70°C
AOM-5721C0-543AA1	QCS5430	4G	64G eMMC	4	2	1	5	1 x DP +1 x 4 lane MIPI DSI (or 1 x DP + 1 x eDP)	1	3	2	0°C ~ 60°C

* DRAM and eMMC of other capacity are available through project-based support. Please contact sales for details.

Development Board

Part No.	Description
AOM-DB6700-SCNA1	Carrier Board

Optional Accessories

Part No.	Description
1701200220	Debug port cable
1700019474	D-SUB 9P(F)/D-SUB 9P(F) RS232/RS485 100c
1970006306N001	Heat Spreader
1970005259T001	Semi Heat Sink (0 ~ 60 °C)
1970005260T001	Semi Heat Sink (-20 ~ 70 °C)
96PSA-A36W12R1-3	ADAPTER 100-240V 36W 12V 3A
1700001524	Power Cord 3P UL 10A 125V 180cm
170203183C	Power Cord 3P Europe (WS-010+WS-083) 183cm
1700019146	Power Cord CCC 3P 10A 250V 183cm
170203180A	Power Cord 3P UK 2.5A/3A 250V 1.83M
1700008921	Power Cord 3P PSE 183cm
SQF-ISDM1-16G-21C	SQF SD Card I-SD UHS-I MLC 16G (0-70°C)
SQF-ISDM1-16G-21E	SQF I-SD UHS-I MLC 16G (-40-85°C)
AIW-170BQ-001	Qualcomm WiFi6E M.2 2230 E key
AIW-512-1 (1751000651-01)	Dipole Ant. WiFi 6E SMA/M-R BLK L111.7mm IP54
1751000621-01	Cable Ant. SMA/F-R MHF4L/113 BLK L250mm
AIW-356DQ-E01	5G Sub6+GNSS M.2 3052 Key B, USB only sku
AIW-532 (1750009372-01)	Ant. SMA/M 90/180 5G BLK 167mm RG178
1751000624-01	Cable Ant. SMA/F MHF4L/113 BLK L250mm

Dimensions

Unit: mm

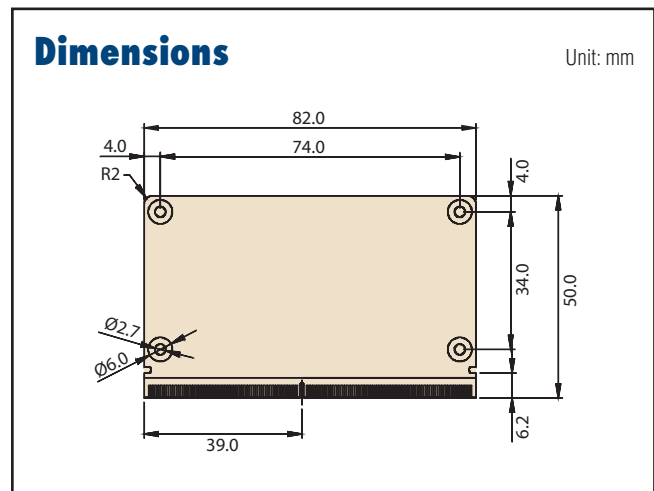

*Please contact us for suggesting suitable cellular module for your region.