

AOM-5841

Rockchip RK3576 Cortex-A72&A53 SMARC 2.2 AI-on-Module

NEW

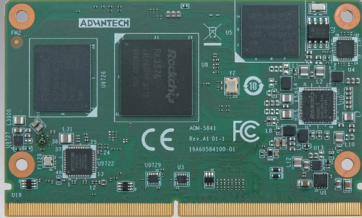

Features

- Rockchip RK3576 Quad Cortex-A72 & Quad Cortex-A53
- Onboard 4/8GB LPDDR5 memory and 64GB eMMC
- Built-in NPU with processing performance of up to 6 TOPS
- Supports 1 x HDMI/eDP, 1 x DP, 1 x MIPI-DSI
- Supports 8K@30fps/4K@120fps H.264/H.265 video decoder
- 1 x USB 3.2 Gen1 Signal , 1 x USB 2.0, 1 x USB 2.0 OTG, 4 x UART
- 1 x PCIe 2.1, 2 x MIPI CSI, 2 x Gigabit LAN
- Supports Linux Debian 12 & Android 15



Introduction

Advantech AOM-5841 SMARC 2.2 AI-on-Module is powered by the Rockchip RK3576 SOC, which includes Quad Core Arm Cortex-A72 & Quad Core Arm Cortex-A53 processor and Arm Mali-G52 3D graphics engine. It provides a rich display interface: HDMI2.0 / eDP1.3, DP1.4 and MIPI DSI-2 to meet specific requirements. It also features USB 3.0, PCIe 2.1, Gigabit Ethernet, and MIPI-CSI for embedded applications. It is the ideal solution for POS, Robotic, infotainment, and medical applications.

AOM-5841 is paired with the Advantech SOM-DB2510 development board for faster end-product peripheral integration and time-to-market. The reference schematics and layout checklist documentation for carrier board development is provided along with the open-sourced Linux BSP, test utilities, hardware design utilities, and reference drivers.

Specifications

Form Factor		SMARC 2.2
Processor System	CPU	Rockchip RK3576 Arm Quad Core Cortex-A72 and Quad Core Cortex-A53
	NPU	6 Tops
Memory	Technology	LPDDR5
	Capacity	Onboard 4/8GB
	Flash	64 GB eMMC NAND Flash for OS and boot loader
Graphics	MIPI DSI	1 x 4-lane MIPI-DSI
	HDMI	1 x HDMI2.0 (default)
	eDP	1 x eDP1.3(shared with HDMI,by bom option)
	DP	1 x DP 1.4
	Graphics Engine	Arm Mali-G52 GPU, supports OpenGL ES1.1/2.0/3.2, OpenCL 2.0, Vulkan 1.1
	H/W Video Codec	Decoder: H.264,H.264, VP9, AV1 & AVS2 etc up to 8K@30fps/4K@120fps Encoder: H.264/H.265 up to 4K@60fps @ 100fps
Ethernet	Chipsset	2 x PHY
	Speed	2 x 10/100/1000 Mbps
RTC	RTC	Yes
Watchdog Timer		HW watchdog by MCU
I/O	PCIe	1 x PCIe 2.1 x1 (default)
	SATA	1 x SATA 3.0 (shared with PCIe, by BOM option)
	USB	1 x USB 3.1 signal, 1 x USB 2.0, 1 x USB 2.0 OTG
	Audio	1 x I ^S
	S/PDIF	-
	SDIO	1
	Serial Port	1 x 2-wire UART 2 x 4-wire UART
	Debug	1 x 2-wire UART for debug console
	SPI	2
	CAN	2
	GPIO	14
	I ² C	5
	Camera Input	1 x 4-lane MIPI CSI 1 x 2-lane MIPI CSI
	System Bus	-
Touch	-	
Keypad	-	
Power	Power Supply Voltage	4.75~5.25V DC source
	Power Consumption	6.99W @ 5V (Max)1.49W @ 5V (Idle)
Environment	Operating Temperature Range	0 ~ 70°C / -40 ~ 85°C
	Operating Humidity	40°C @ 95% relative humidity, non-condensing
Mechanical	Dimensions (W x D)	82 x 50 mm
Operating System		Linux Debian 12 and Android 15
Certifications		CE/UKCA/FCC Class B

Block Diagram

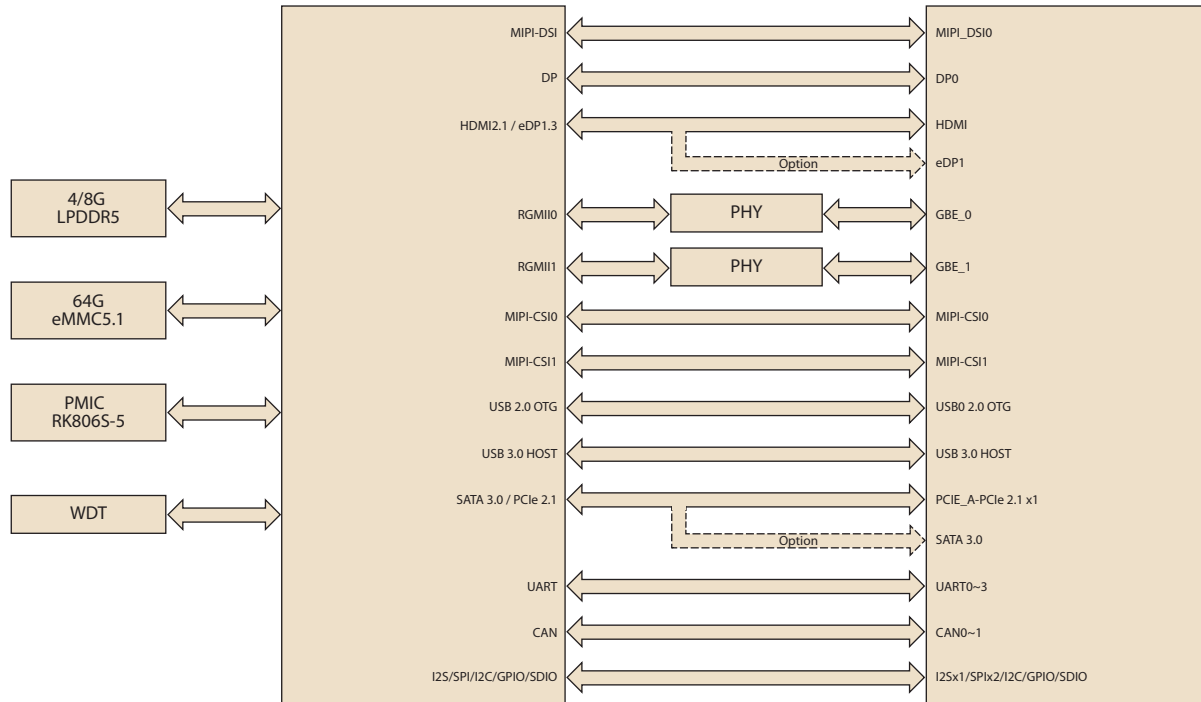

Ordering Information

DDR and eMMC of other capacity and Display are available through project-based support. Please contact us for details.

Part No.	CPU	Memory	Flash Memory	UART	LAN	USB 3.0/2.0	Display	PCIe 2.1	SD	IPC	SPI	CAN	Power input	Operating Temperature
AOM-5841C8-3576AA1	RK3576	4 GB	64 GB	4	2	1 USB 3.0 1 USB 2.0 OTG	1 x HDMI 2.0 1 x MIPI DSI 1 x DP	1	1	5	2	2	5V	0 ~ 70°C

Development Board

Part No.	Description
SOM-DB2510-R0A1	Development board for SMARC 2.1 RISC Module

Optional Accessories

Part No.	Description
1701200220	Debug Cable
1970006459N001	Heat spreader
1970004755T001	Heat sink
96PSA-A36W12R1-3	ADAPTER 100-240V 36W 12V 3A
1700001524	Power cord 3P UL 10A 125V 180cm
170203183C	Power cord 3P Europe (WS-010+WS-083)183cm
1700008921	Power cord 3P PSE 183cm
170203180A	Power cord 3P UK 2.5A/3A 250V 1.83m
SQF-ISDM1-16G-21C	SQ Flash SD card UHS-I MLC 16GB (0 ~ 70 °C)
SQF-ISDM1-16G-21E	SQ Flash SD card UHS-I MLC 16GB (-40 ~ 85 °C)

Dimensions

Unit: mm

