

Advantech

AQD-D5V16GE56-SB
Datasheet

Rev. 1.0

2024-05-23

Description

AQD-D5V16GE56-SB is DDR5-5600(CL46)-45-45 SDRAM memory module. The SPD is programmed to JEDEC standard latency 5600Mbps timing of 46-45-45 at 1.1V. The module is composed of 16Gb CMOS DDR5 SDRAMs in FBGA package and one 8Kbit SPD Hub in 8pin TDFN package on a 288pin glass-epoxy printed circuit board.

The module is a Dual In-line Memory Module and intended for mounting onto 288 pins edge connector sockets. Synchronous design allows precise cycle control with the use of system clock. Data I/O transactions are possible on both edges of DQS. Range of operating frequencies, programmable latencies and burst lengths allow the same device to be useful for a variety of high bandwidth, high performance memory system applications.

Features

- RoHS compliant products.
- JEDEC standard 1.1V(1.067V~1.166V) Power supply
- VDDQ= 1.1V(1.067V~1.166V)
- VPP = 1.8V(+0.108V / -0.054V)
- Data transfer rates: PC5-5600
- Programmable CAS Latency:
22,26,28,30,32,36,40,42,46
- 16 bit pre-fetch
- Burst Length (BL) switch on-the-fly BL16 or BC8
- Bi-directional Differential Data-Strobe
- On Die Termination, Nominal, Park
- Serial presence detect hub (SPD Hub) with
Integrated Temperature sensor
- Asynchronous reset
- PCB edge connector treated with 30u" Gold-Plating

Pin Descriptions

Pin Name	Description	Pin Name	Description
CA[6:0]_A CA[6:0]_B	Address and Command Bus	DQ[31:0]_A DQ[31:0]_B	DIMM memory Data bus channel A & B
CS[1:0]_A CS[1:0]_B	Chip Select	CB[7:0]_A CB[7:0]_B	DIMM ECC Checkbits (CB) channel A & B
PAR_A PAR_B	Parity input	DQS[9:0]_A_t DQS[9:0]_B_t	Data Strobes (positive line of differential pair)
CK_t	Clocks (true/positive)	DQS[9:0]_A_c DQS[9:0]_B_c	Data Strobes (negative line of differential pair)
CK_c	Clocks (complement/negative)	TDQS[9:5]_A_t TDQS[9:5]_B_t	Not valid for x4 operation. Enabled via Mode Register.
ALERT_n	Alert for CRC error	TDQS[9:5]_A_c TDQS[9:5]_B_c	Not valid for x4 operation. Enabled via Mode Register.
RESET_n	Set DRAM to known state	VIN_BULK	DIMM Power Supply from system to PMIC
PCAMP	Control and Monitor Port	VIN_MGMT	DIMM Power Supply from system to PMIC
HSCL	I2C/I3C-Basic Host Sideband Bus Clock	VSS	Power supply return (ground)
HSDA	I2C/I3C-Basic Host Sideband Bus Data	RFU	Reserved for future use
HSA	I2C/I3C-Basic Host Sideband Bus Address	LBDQS	Loopback Data strobe output
LBDQ	Loopback Data output:		

1. TDQSx and DQSx_t share a pin..

Dimensions (Unit: millimeter)

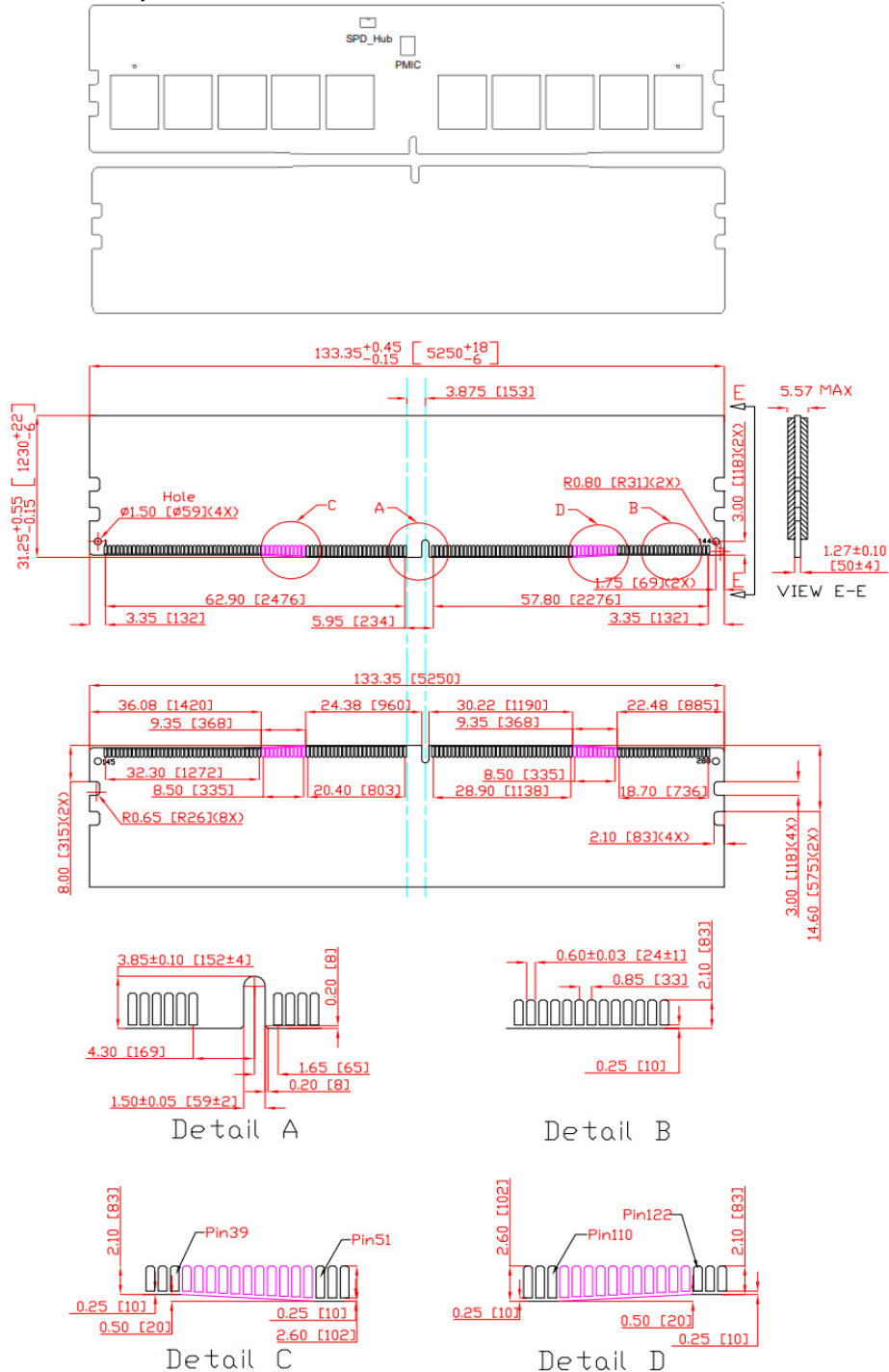

Note:1. Tolerances on all dimensions +/-0.15mm unless otherwise specified.

Pin Assignments

288-Pin DDR5 UDIMM Front								288-Pin DDR5 UDIMM Back							
Pin	Symbol	Pin	Symbol	Pin	Symbol	Pin	Symbol	Pin	Symbol	Pin	Symbol	Pin	Symbol	Pin	Symbol
1	VIN_BULK	37	DQ20_A	73	CK0_A_c	109	V _{SS}	145	VIN_BULK	181	DQ22_A	217	CK1_A_c	253	V _{SS}
2	RFU	38	V _{SS}	74	V _{SS}	110	DQ5_B	146	VIN_BULK	182	V _{SS}	218	V _{SS}	254	DQ7_B
3	RFU	39	DQ21_A	75	RFU	111	V _{SS}	147	PWR_GOOD	183	DQ23_A	219	RFU	255	V _{SS}
4	HSCL	40	V _{SS}	76	RFU	112	DQ8_B	148	HSA	184	V _{SS}	220	RFU	256	DQ10_B
5	HSDA	41	DQ24_A	77	V _{SS}	113	V _{SS}	149	RFU	185	DQ26_A	221	V _{SS}	257	V _{SS}
6	V _{SS}	42	V _{SS}	78	CK0_B_t	114	DQ9_B	150	V _{SS}	186	V _{SS}	222	CK1_B_t	258	DQ11_B
7	RFU	43	DQ25_A	79	CK0_B_c	115	V _{SS}	151	PWR_EN	187	DQ27_A	223	CK1_B_c	259	V _{SS}
8	V _{SS}	44	V _{SS}	80	V _{SS}	116	DM1_B_n	152	RFU	188	V _{SS}	224	V _{SS}	260	DQ51_B_c
9	DQ0_A	45	DM3_A_n	81	RFU	117	V _{SS}	153	V _{SS}	189	DQS3_A_c	225	RFU	261	DQ51_B_t
10	V _{SS}	46	V _{SS}	82	CA12_B	118	DQ12_B	154	DQ2_A	190	DQS3_A_t	226	RFU	262	V _{SS}
11	DQ1_A	47	DQ28_A	83	V _{SS}	119	V _{SS}	155	V _{SS}	191	V _{SS}	227	V _{SS}	263	DQ14_B
12	V _{SS}	48	V _{SS}	84	CA10_B	120	DQ13_B	156	DQ3_A	192	DQ30_A	228	CA11_B	264	V _{SS}
13	DQS0_A_c	49	DQ29_A	85	CA8_B	121	V _{SS}	157	V _{SS}	193	V _{SS}	229	CA9_B	265	DQ15_B
14	DQS0_A_t	50	V _{SS}	86	V _{SS}	122	DQ16_B	158	DM0_A_n	194	DQ31_A	230	V _{SS}	266	V _{SS}
15	V _{SS}	51	CB0_A	87	CA6_B	123	V _{SS}	159	V _{SS}	195	V _{SS}	231	CA7_B	267	DQ18_B
16	DQ4_A	52	V _{SS}	88	CA4_B	124	DQ17_B	160	DQ6_A	196	CB2_A	232	CA5_B	268	V _{SS}
17	V _{SS}	53	CB1_A	89	V _{SS}	125	V _{SS}	161	V _{SS}	197	V _{SS}	233	V _{SS}	269	DQ19_B
18	DQ5_A	54	V _{SS}	90	CA2_B	126	DQS2_B_c	162	DQ7_A	198	CB3_A	234	CA3_B	270	V _{SS}
19	V _{SS}	55	DQS4_A_c	91	CA0_B	127	DQS2_B_t	163	V _{SS}	199	V _{SS}	235	CA1_B	271	DM2_B_n
20	DQ8_A	56	DQS4_A_t	92	V _{SS}	128	V _{SS}	164	DQ10_A	200	ALERT_n	236	V _{SS}	272	V _{SS}
21	V _{SS}	57	V _{SS}	93	CS0_B_n	129	DQ20_B	165	V _{SS}	201	V _{SS}	237	CS1_B_n	273	DQ22_B
22	DQ9_A	58	CS0_A_n	94	V _{SS}	130	V _{SS}	166	DQ11_A	202	CS1_A_n	238	V _{SS}	274	V _{SS}
23	V _{SS}	59	V _{SS}	95	RESET_n	131	DQ21_B	167	V _{SS}	203	V _{SS}	239	DQS4_B_c	275	DQ23_B
24	DM1_A_n	60	CA0_A	96	V _{SS}	132	V _{SS}	168	DQS1_A_c	204	CA1_A	240	DQS4_B_t	276	V _{SS}
25	V _{SS}	61	CA2_A	97	CB0_B	133	DQ24_B	169	DQS1_A_t	205	CA3_A	241	V _{SS}	277	DQ26_B
26	DQ12_A	62	V _{SS}	98	V _{SS}	134	V _{SS}	170	V _{SS}	206	V _{SS}	242	CB2_B	278	V _{SS}
27	V _{SS}	63	CA4_A	99	CB1_B	135	DQ25_B	171	DQ14_A	207	CA5_A	243	V _{SS}	279	DQ27_B
28	DQ13_A	64	CA6_A	100	V _{SS}	136	V _{SS}	172	V _{SS}	208	CA7_A	244	CB3_B	280	V _{SS}
29	V _{SS}	65	V _{SS}	101	DQ0_B	137	DM3_B_n	173	DQ15_A	209	V _{SS}	245	V _{SS}	281	DQS3_B_c
30	DQ16_A	66	CA8_A	102	V _{SS}	138	V _{SS}	174	V _{SS}	210	CA9_A	246	DQ2_B	282	DQS3_B_t
31	V _{SS}	67	CA10_A	103	DQ1_B	139	DQ28_B	175	DQ18_A	211	CA11_A	247	V _{SS}	283	V _{SS}
32	DQ17_A	68	V _{SS}	104	V _{SS}	140	V _{SS}	176	V _{SS}	212	V _{SS}	248	DQ3_B	284	DQ30_B
33	V _{SS}	69	CA12_A	105	DQS0_B_c	141	DQ29_B	177	DQ19_A	213	RFU	249	V _{SS}	285	V _{SS}
34	DQS2_A_c	70	RFU	106	DQS0_B_t	142	V _{SS}	178	V _{SS}	214	RFU	250	DM0_B_n	286	DQ31_B
35	DQS2_A_t	71	V _{SS}	107	V _{SS}	143	RFU	179	DM2_A_n	215	V _{SS}	251	V _{SS}	287	V _{SS}
36	V _{SS}	72	CK0_A_t	108	DQ4_B	144	RFU	180	V _{SS}	216	CK1_A_t	252	DQ6_B	288	RFU

Function Block Diagram

1Rank, x8 DDR5 SDRAMs

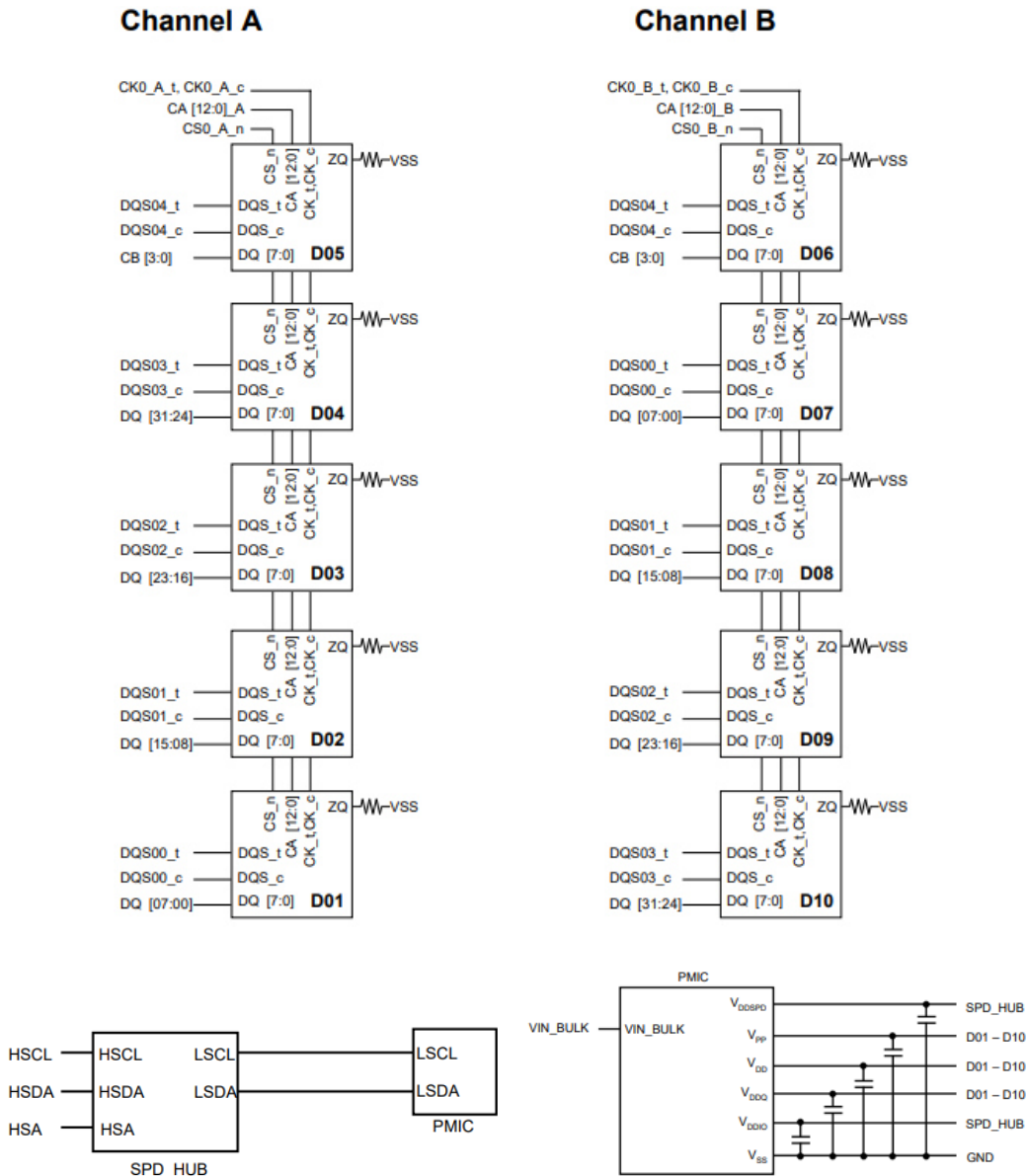

Note : ZQ resistors are 240 Ω ± 1%.

This technical information is based on industry standard data and tests believed to be reliable. However, Advantech makes no warranties, either expressed or implied, as to its accuracy and assume no liability in connection with the use of this product. Advantech reserves the right to make changes in specifications at any time without prior notice.

Operating Temperature Condition

Parameter	Symbol	Rating	Unit	Note
Operating Temperature	TOPER	0 to 85	°C	1,2

Note: Operating Temperature is the case surface temperature on the center/top side of the DRAM. For the measurement conditions, please refer to JESD51-2 standard.

Absolute Maximum DC Ratings

Parameter	Symbol	Value	Unit	Note
Voltage on VDD relative to Vss	VDD	-0.3 ~ 1.4	V	1
Voltage on VDDQ pin relative to Vss	VDDQ	-0.3 ~ 1.4	V	1
Voltage on any pin relative to Vss	VIN, VOUT	-0.3 ~ 1.4	V	1
Storage temperature	TSTG	-55~+100	°C	1,2

Note: 1. Stress greater than those listed under “Absolute Maximum Ratings” may cause permanent damage to the device. This is a stress rating only and functional operation of the device at these or any other conditions above those indicated in the operational sections of this specification is not implied. Exposure to absolute maximum rating conditions for extended periods may affect reliability.
 2. Storage Temperature is the case surface temperature on the center/top side of the DRAM. For the measurement conditions, please refer to JESD51-2 standard.

AC & DC Operating Conditions

Recommended DC operating conditions

Parameter	Symbol	Voltage	Rating			Unit	Notes
			Min	Typ.	Max		
Host Supply Voltage	VIN_BULK	12.0	4.25	5.0	5.5	V	
PMIC Output Supply Voltage	VDD	1.1	1.067	1.1	1.166	V	1,2,3
PMIC Output Supply Voltage	VDDQ	1.1	1.067	1.1	1.166	V	1,2,3
PMIC Output Supply Voltage	VPP	1.8	1.746	1.8	1,908	V	3
AC Input Logic High	VIH(AC)	TBD	-	-	-	mV	
AC Input Logic Low	VIL(AC)	TBD	-	-	-	mV	
DC Input Logic High	VIH(DC)	TBD	-	-	-	mV	
DC Input Logic Low	VIL(DC)	TBD	-	-	-	mV	

Note: (1) VDD must be within 66mv of VDDQ
 (2) AC parameters are measured with VDD and VDDQ tied together.
 (3) This includes all voltage noise from DC to 2 MHz at the DRAM package ball.

IDD Specification parameters Definition - 16GB

Symbol	Condition	16GB	Unit
IDD0	One bank ACTIVATE-PRECHARGE current	TBD	mA
IDD0F	Operating Four Bank Active-Precharge Current	TBD	mA
IDD2N	Precharge Standby Current	TBD	mA
IDD2P	Precharge Power-Down Current	TBD	mA
IDD3N	Active standby current	TBD	mA
IDD3P	Active Power-Down Current	TBD	mA
IDD4R	Burst Read Current	TBD	mA
IDD4W	Burst write current	TBD	mA
IDD5B	Burst Refresh Current (1x REF)	TBD	mA
IDD5C	Burst Refresh Current (Same Bank Refresh Mode)	TBD	mA
IDD6N	Self refresh current: Normal temperature range (0–85°C)	TBD	mA
IDD7	Bank interleave read current	TBD	mA
IDD8	Maximum power-down current	TBD	mA

■ Timing Parameters & Specifications

Parameter	Symbol	DDR5-4800		DDR5-5600		DDR5-6400		Unit	Notes
		Min	Max	Min	Max	Min	Max		
Clock Timing									
Clock period average	tCK (AVG)	0.416	<0.454	0.357	<0.384	0.312	<0.333	ns	1
Command and Address Timing									
Read to Read command delay for same bank group	tCCD_L	max(8nCK, 5ns)	–	max(8nCK, 5ns)	–	max(8nCK, 5ns)	–	nCK,ns	8
Write to Write command delay for same bank group	tCCD_L_WR	max(32nCK, 20ns)	–	max(32nCK, 20ns)	–	max(32nCK, 20ns)	–	nCK,ns	8
Write to Write command delay for same bank group, second write not RMW	tCCD_L_WR2	max(16nCK, 10ns)	–	max(16nCK, 10ns)	–	max(16nCK, 10ns)	–	nCK,ns	8
Read to Write command delay for same bank group	tCCD_L_RTW	CL - CWL + RBL/2 + 2tCK - (Read DQS offset) + (tRPST - 0.5tCK) + tWPRE						nCK,ns	3,5,6,8
Write to Read command delay for same bank group	tCCD_L_WTR	CWL + WBL/2 + Max(16nCK, 10ns)						nCK,ns	4,6,8
Read to Read command delay for different bank group	tCCD_S	8	–	8	–	8	–	nCK	8
Write to Write command delay for different bank group	tCCD_S_WR	8	–	8	–	8	–	nCK	8
Read to Write command delay for different bank group	tCCD_S_RTW	CL - CWL + RBL/2 + 2tCK - (Read DQS offset) + (tRPST - 0.5tCK) + tWPRE						nCK,ns	3,5,6,8
Write to Read command delay for different bank group	tCCD_S_WTR	CWL + WBL/2 + Max(4nCK, 2.5ns)						nCK,ns	4,6,8
Write to Read with Auto Precharge command delay for same bank	tCCD_WTRA	CWL + WBL/2 + tWR - tRTP						nCK,ns	2,4,6,8

Parameter	Symbol	DDR5-4800		DDR5-5600		DDR5-6400		Unit	Notes
		Min	Max	Min	Max	Min	Max		
Activate to Activate command delay to same bank group for 1KB page size	tRRD_L(1K)	max(8nCK, 5ns)	–	max(8nCK, 5ns)	–	max(8nCK, 5ns)	–	nCK,ns	8
Activate to Activate command delay to same bank group for 2KB page size	tRRD_L(2K)	max(8nCK, 5ns)	–	max(8nCK, 5ns)	–	max(8nCK, 5ns)	–	nCK,ns	8
Activate to Activate command delay to different bank group for 1KB page size	tRRD_S(1K)	8	–	8	–	8	–	nCK	8
Activate to Activate command delay to different bank group for 2KB page size	tRRD_S(2K)	8	–	8	–	8	–	nCK	8
Four activate window for 1KB page size	tFAW (1K)	Max(32nCK, 13.333ns)	–	Max(32nCK, 11.428ns)	–	Max(32nCK, 10.000ns)	–	nCK,ns	
Four activate window for 2KB page size	tFAW (2K)	Max(40nCK, 16.666ns)	–	Max(40nCK, 14.285ns)	–	Max(40nCK, 12.500ns)	–	nCK,ns	
Read to Precharge command delay	tRTP	Max(12nCK, 7.5ns)	–	Max(12nCK, 7.5ns)	–	Max(12nCK, 7.5ns)	–	nCK,ns	8
Precharge to Precharge command delay	tPPD	2	–	2	–	2	–	nCK	7,8
Write recovery time	tWR	30	–	30	–	30	–	ns	8

Notes:

1. tCK(avg)min listed for reference only, refer to the Speed Bins and Operations section which lists all valid tCK(avg) values.
2. tCCD_WTRA(min) shall always be greater than or equal to $CWL + WBL/2 + tWR(min) - tRTP(min)$, and when using the appropriate rounding algorithms, nCCD_WTRA(min) shall always be greater than or equal to $CWL + WBL/2 + nWR(min) - nRTP(min)$.
3. RBL: Read burst length associated with Read command
 - RBL = 32 (36 w/ RCRC on) for fixed BL32 and BL32 in BL32 OTF mode
 - RBL = 16 (18 w/ RCRC on) for fixed BL16 and BL16 in BL32 OTF mode
 - RBL = 16 (18 w/ RCRC on) for BL16 in BC8 OTF mode and BC8 in BC8 OTF mode
4. WBL: Write burst length associated with Write command
 - WBL = 32 (36 w/ WCRC on) for fixed BL32 and BL32 in BL32 OTF mode
 - WBL = 16 (18 w/ WCRC on) for fixed BL16 and BL16 in BL32 OTF mode
 - WBL = 16 (18 w/ WCRC on) for BL16 in BC8 OTF mode and BC8 in BC8 OTF mode
5. 5 - The following is considered for tRTW equation
 - 1tCK needs to be added due to tDQS2CK
 - Read DQS offset timing can pull in the tRTW timing
 - 1tCK needs to be added when 1.5tCK postamble
6. CWL=CL-2
7. tPPD applies to any combination of precharge commands (PREab, PREsb, PREpb). tPPD also applies to any combination of precharge commands to a different die in a 3DS DDR5 SDRAM.
8. This parameter only specifies minimum values (there is no maximum value). The maximum value cells have been merged in the table to improve legibility.



Enabling an Intelligent Planet

288Pin DDR5 5600 1.1V ECC-DIMM
 16GB Based on 2048Mx8
 AQD-D5V16GE56-SB

SERIAL PRESENCE DETECT SPECIFICATION

Byte	Function Described	Function	HEX Value
0	Number of Bytes in SPD Device	SPD Total: 1024Bytes	30
1	SPD Revision for Base Configuration Parameters	Version 1.1	11
2	Key Byte / Host Bus Command Protocol Type	DDR5 SDRAM	12
3	Key Byte / Module Type	U-DIMM	02
4	First SDRAM Density and Package	Monolithic SDRAM 16Gb	04
5	First SDRAM Addressing	Row : 16 Column : 10	00
6	First SDRAM I/O Width	x8	20
7	First SDRAM Bank Groups & Banks Per Bank Group	8 bank groups/4 banks per bank group	62
8	Second SDRAM Density and Package		00
9	Second SDRAM Addressing		00
10	Secondary SDRAM I/O Width		00
11	Second SDRAM Bank Groups & Banks Per Bank Group		00
12	SDRAM BL32 & Post Package Repair	One repair element per bank group Burst length 32 supported	30
13	SDRAM Duty Cycle Adjuster & Partial Array Self Refresh	Device supports DCA for 4-phase (internal clock's)	02
14	SDRAM Fault Handling	Writeback suppression control in MR9	00
15	Reserved	must be coded as 0x00	00
16	SDRAM Nominal Voltage, VDD	Operable:1.1V Endurant:1.1V	00
17	SDRAM Nominal Voltage, VDDQ	Operable:1.1V Endurant:1.1V	00
18	SDRAM Nominal Voltage, VPP	Operable:1.8V Endurant:1.8V	00
19	SDRAM Timing	Standard core timings per JESD79-5	00
20	SDRAM Minimum Cycle Time (tCKAVGmin), Least Significant Byte		65
21	SDRAM Minimum Cycle Time (tCKAVGmin), Most Significant Byte	357 ps	01
22	SDRAM Maximum Cycle Time (tCKAVGmax), Least Significant Byte		F2
23	SDRAM Maximum Cycle Time (tCKAVGmax), Most Significant Byte	1010 ps	03
24	SDRAM CAS Latencies Supported:First Byte	CL22,26,28,30,32	7A
25	SDRAM CAS Latencies Supported:Second Byte	CL36,40,42,46,50	AD
26	SDRAM CAS Latencies Supported:Third Byte	-	00
27	SDRAM CAS Latencies Supported:Fourth Byte	-	00
28	SDRAM CAS Latencies Supported:Fifth Byte	-	00
29	Reserved	must be coded as 0x00	00
30	SDRAM Minimum CAS Latency Time (tAAmin), Least Significant Byte		80
31	SDRAM Minimum CAS Latency Time (tAAmin), Most Significant Byte	16000 ps	3E
32	SDRAM Minimum RAS to CAS Delay Time (tRCDmin), Least Significant Byte		80
33	SDRAM Minimum RAS to CAS Delay Time (tRCDmin), Most Significant Byte	16000 ps	3E
34	SDRAM Minimum Row Precharge Delay Time (tRPmin), Least Significant Byte		80
35	SDRAM Minimum Row Precharge Delay Time (tRPmin), Most Significant Byte	16000 ps	3E
36	SDRAM Minimum Active to Precharge Delay Time (tRASmin), Least Significant Nibble		00
37	SDRAM Minimum Active to Precharge Delay Time (tRASmin), Most Significant Byte	32000 ps	7D
38	SDRAM Minimum Active to Active/Refresh Delay Time (tRCmin), Least Significant Nibble		80
39	SDRAM Minimum Active to Active/Refresh Delay Time (tRCmin), Most Significant Nibble	48000 ps	BB
40	SDRAM Minimum Write Recovery Time (tWRmin), Least Significant Nibble		30
41	SDRAM Minimum Write Recovery Time (tWRmin), Most Significant Nibble	30000 ps	75
42	SDRAM Minimum Refresh Recovery Delay Time (tRFC1min, tRFC1 sir min),Least Significant Byte		27
43	SDRAM Minimum Refresh Recovery Delay Time (tRFC1min, tRFC1 sir min),Most Significant Byte	295 ns	01
44	SDRAM Minimum Refresh Recovery Delay Time (tRFC2min, tRFC2 sir min),Least Significant Byte		A0
45	SDRAM Minimum Refresh Recovery Delay Time (tRFC2min, tRFC2 sir min),Most Significant Byte	160 ns	00
46	SDRAM Minimum Refresh Recovery Delay Time (tRFCsmin, tRFCsb sir min),Least Significant Byte		82
47	SDRAM Minimum Refresh Recovery Delay Time (tRFCsmin, tRFCsb sir min),Most Significant Byte	130 ns	00
48	SDRAM Minimum Refresh Recovery Delay Time, 3DS Different Logical Rank(tRFC1 dir min),Least Significant Byte		00
49	SDRAM Minimum Refresh Recovery Delay Time, 3DS Different Logical Rank(tRFC1 dir min),Most Significant Byte	monolithic SDRAMs	00
50	SDRAM Minimum Refresh Recovery Delay Time, 3DS Different Logical Rank(tRFC2 dir min),Least Significant Byte		00
51	SDRAM Minimum Refresh Recovery Delay Time, 3DS Different Logical Rank(tRFC2 dir min),Most Significant Byte	monolithic SDRAMs	00
52	SDRAM Minimum Refresh Recovery Delay Time, 3DS Different Logical Rank(tRFCsb dir min),Least Significant Byte		00
53	SDRAM Minimum Refresh Recovery Delay Time, 3DS Different Logical Rank(tRFCsb dir min),Most Significant Byte	monolithic SDRAMs	00
54	SDRAM Refresh Management, First Byte, First SDRAM		00
55	SDRAM Refresh Management, Second Byte, First SDRAM		00
56	SDRAM Refresh Management, First Byte, Second SDRAM		00
57	SDRAM Refresh Management, Second Byte, Second SDRAM		00
58	SDRAM Adaptive Refresh Management, First SDRAM, First Byte,Level A		00
59	SDRAM Adaptive Refresh Management, First SDRAM, Second Byte,Level A		00
60	SDRAM Adaptive Refresh Management, Second SDRAM, First Byte,Level A		00

第 1 頁



Enabling an Intelligent Planet

288Pin DDR5 5600 1.1V ECC-DIMM
 16GB Based on 2048Mx8
 AQD-D5V16GE56-SB

61	SDRAM Adaptive Refresh Management, Second SDRAM, Second Byte,Level A			00
62	SDRAM Adaptive Refresh Management, First SDRAM, First Byte,Level B			00
63	SDRAM Adaptive Refresh Management, First SDRAM, Second Byte,Level B			00
64	SDRAM Adaptive Refresh Management, Second SDRAM, First Byte,Level B			00
65	SDRAM Adaptive Refresh Management, Second SDRAM, Second Byte,Level B			00
66	SDRAM Adaptive Refresh Management, First SDRAM, First Byte,Level C			00
67	SDRAM Adaptive Refresh Management, First SDRAM, Second Byte,Level C			00
68	SDRAM Adaptive Refresh Management, Second SDRAM, First Byte,Level C			00
69	SDRAM Adaptive Refresh Management, Second SDRAM, Second Byte,Level C			00
70	SDRAM Minimum Active to Active Command Delay Time, Same Bank Group,(tRRD Lmin)Least Significant Byte	5000 ps		88
71	SDRAM Minimum Active to Active Command Delay Time, Same Bank Group,(tRRD Lmin)Most Significant Byte			13
72	SDRAM Minimum Active to Active Command Delay Time, Same Bank Group,(tRRD Lmin)Lower Clock Limit	8 nCK		08
73	SDRAM Minimum CAS n to CAS n Command Delay Time, Same Bank Group,(tCCD Lmin)Least Significant Byte	5000 ps		88
74	SDRAM Minimum CAS n to CAS n Command Delay Time, Same Bank Group,(tCCD Lmin)Most Significant Byte			13
75	SDRAM Minimum CAS n to CAS n Command Delay Time, Same Bank Group,(tCCD Lmin)Lower Clock Limit	8 nCK		08
76	SDRAM Minimum Write CAS n to Write CAS n Command Delay Time, Same Bank Group (tCCD L WRmin)Least Significant Byte	20000 ps		20
77	SDRAM Minimum Write CAS n to Write CAS n Command Delay Time, Same Bank Group (tCCD L WRmin)Most Significant Byte			4E
78	SDRAM Minimum Write CAS n to Write CAS n Command Delay Time, Same Bank Group (tCCD L WRmin)Lower Clock Limit	32 nCK		20
79	SDRAM Minimum Write CAS n to Write CAS n Command Delay Time, Same Bank Group (tCCD L WR2min)Least Significant Byte	10000 ps		10
80	SDRAM Minimum Write CAS n to Write CAS n Command Delay Time, Same Bank Group (tCCD L WR2min)Most Significant Byte			27
81	SDRAM Minimum Write CAS n to Write CAS n Command Delay Time, Same Bank Group (tCCD L WR2min)Lower Clock Limit	16 nCK		10
82	SDRAM Minimum Four Activate Window (tFAWmin)Least Significant Byte	11428 ps		A4
83	SDRAM Minimum Four Activate Window (tFAWmin)Most Significant Byte			2C
84	SDRAM Minimum Four Activate Window (tFAWmin)Lower Clock Limit	32 nCK		20
85	SDRAM Write to Read Command Delay for Same Bank Group (tCCD L WTR)Least Significant Byte	10000 ps		10
86	SDRAM Write to Read Command Delay for Same Bank Group (tCCD L WTR) Most Significant Byte			27
87	SDRAM Write to Read Command Delay for Same Bank Group (tCCD L WTR)Lower Clock Limit	16 nCK		10
88	SDRAM Write to Read Command Delay for Different Bank Group (tCCD S WTR) Least Significant Byte	2500 ps		C4
89	SDRAM Write to Read Command Delay for Different Bank Group (tCCD S WTR) Most Significant Byte			05
90	SDRAM Write to Read Command Delay for Different Bank Group,(tCCD S WTR) Lower Clock Limit	4 nCK		04
91	SDRAM Read to Precharge Command Delay (tRTP, tRTP slr) Least Significant Byte	7500 ps		4C
92	SDRAM Read to Precharge Command Delay (tRTP, tRTP slr) Most Significant Byte			1D
93	SDRAM Read to Precharge Command Delay (tRTP, tRTP slr) Lower Clock Limit	12 nCK		0C
94-127	Reserved, Base Configuration Section	Must be coded as 0x00		00
128-191	Reserved for future use	Reserved for future use		00
192	SPD Revision for Module Information	Version 1.0		10
193	Hashing Sequence	No authentication		00
194	SPD Manufacturer ID Code, First Byte	By SPD_Hub & PMIC Vendor & Revision *Note: 1		-
195	SPD Manufacturer ID Code, Second Byte			-
196	SPD Device Type			-
197	SPD Device Revision Number			-
198	PMIC 0 Manufacturer ID Code, First Byte			-
199	PMIC 0 Manufacturer ID Code, Second Byte			-
200	PMIC 0 Device Type		-	
201	PMIC 0 Revision Number		-	
202	PMIC 1 Manufacturer ID Code, First Byte		00	
203	PMIC 1 Manufacturer ID Code, Second Byte		00	
204	PMIC 1 Device Type		00	
205	PMIC 1 Revision Number		00	
206	PMIC 2 Manufacturer ID Code, First Byte		00	
207	PMIC 2 Manufacturer ID Code, Second Byte		00	
208	PMIC 2 Device Type		00	
209	PMIC 2 Revision Number		00	
210	Thermal Sensor Manufacturer ID Code, First Byte		00	
211	Thermal Sensor Manufacturer ID Code, Second Byte		00	
212	Thermal Sensor Device Type		00	
213	Thermal Sensor Revision Number		00	
214	DRAM Specification Level		00	
215	SPD Specification Level		00	
216	PMIC0 Specification Level		00	
217	PMIC1 Specification Level		00	
218	PMIC2 Specification Level		00	
219	TS Specification Level		00	
220	DIMM Specification Level		00	

第 2 頁



Enabling an Intelligent Planet

288Pin DDR5 5600 1.1V ECC-DIMM
 16GB Based on 2048Mx8
 AQD-D5V16GE56-SB

221-229	Reserved	Reserved	00
230	(Unbuffered): Module Nominal Height	31.25mm	11
231	(Unbuffered): Module Maximum Thickness	Front,1 < thickness < 2 mm	01
232	(Unbuffered): Reference Row Card Used	Row Card D	03
233	(Unbuffered): DIMM Attributes	Revision 0	81
234	(Unbuffered): Module Organization	0 to +95 °C/1 row DRAM	00
235	Memory Channel Bus Width	1 Package Ranks	2A
236-239	Reserved	2 channels/32 bits/ 4 bits ecc per bus	00
240-447	Reserved	must be coded as 0x00	00
448-509	Reserved for future use	Reserved	00
510	CRC for Byte 0-509,Least Significant Byte	-	-
511	CRC for Byte 0-509,Most Significant Byte	CRC	-
512	Module Manufacturer ID Code, First Byte	-	8A
513	Module Manufacturer ID Code, Second Byte	Advantech	C8
514	Module Manufacturing Location	*Note: 2	-
515	Module Manufacturing Date	*Note: 3 (Decimal)	-
516	Module Manufacturing Date	*Note: 4 (Decimal)	-
517			-
518	Module Serial Number		-
519		*Note: 5 (Decimal)	-
520			-
521			-
522			-
523			-
524			-
525			-
526			-
527			-
528			-
529			-
530			-
531			-
532			-
533			-
534			-
535	Module Part Number		-
536		*Note: 6	-
537			-
538			-
539			-
540			-
541			-
542			-
543			-
544			-
545			-
546			-
547			-
548			-
549			-
550			-
551	Module Revision Code		00
552	DRAM Manufacturer ID Code, First Byte		80
553	DRAM Manufacturer ID Code, Second Byte	Samsung	CE
554	DRAM Stepping		95
555-639	Manufacturer's Specific Data	*Note: 7	-
640	Intel Extreme Memory Profile Identification String		00
641	Intel Extreme Memory Profile Identification String		00
642	Intel Extreme Memory Profile Version		00
643	Intel Extreme Memory Profile Organization		00
644	Intel Extreme Memory Profile Configuration		00
645	PMIC Vendor ID		00



Enabling an Intelligent Planet

288Pin DDR5 5600 1.1V ECC-DIMM

16GB Based on 2048Mx8

AQD-D5V16GE56-SB

646	PMIC Vendor ID		00
647	Number of PMICs		00
648	PMIC Capabilities		00
649-653	RSVD		00
654			00
655			00
656			00
657			00
658			00
659			00
660			00
661	Profile 1 String Name		00
662			00
663			00
664			00
665			00
666			00
667			00
668			00
669			00
670			00
671			00
672			00
673			00
674			00
675			00
676			00
677	Profile 2 String Name		00
678			00
679			00
680			00
681			00
682			00
683			00
684			00
685			00
686			00
687			00
688			00
689			00
690			00
691			00
692			00
693	Profile 3 String Name		00
694			00
695			00
696			00
697			00
698			00
699			00
700			00
701			00
702	Cyclical Redundancy Code (CRC) for Base Configuration Section, Least Significant Byte (for bytes 640-701)		00
703	Cyclical Redundancy Code (CRC) for Base Configuration Section, Most Significant Byte (for bytes 640-701)		00
704	Profile 1 :Module VPP Voltage Level		00
705	Module VDD Voltage Level		00
706	Module VDDQ Voltage Level		00
707	Module TBD Voltage Level - THIS BYTE IS CURRENTLY RSVD		00
708	Memory Controller Voltage Level		00
709	SDRAM Minimum Cycle Time (tCKAVGmin),Least Significant Byte		00
710	SDRAM Minimum Cycle Time (tCKAVGmin),Most Significant Byte		00
711	SDRAM CAS Latencies Supported,First Byte		00
712	SDRAM CAS Latencies Supported,Second Byte		00
713	SDRAM CAS Latencies Supported,Third Byte		00
714	SDRAM CAS Latencies Supported,Fourth Byte		00

第 3 頁



Enabling an Intelligent Planet

288Pin DDR5 5600 1.1V ECC-DIMM
16GB Based on 2048Mx8
AQD-D5V16GE56-SB

Table with columns for ID, Description, and Value. Includes rows for SDRAM CAS Latencies, Minimum CAS Latency Time, Minimum RAS to CAS Delay Time, Minimum Row Precharge Delay Time, Minimum Active to Precharge Delay Time, Minimum Active to Active/Refresh Delay Time, Minimum Write Recovery Time, Minimum Refresh Recovery Delay Time, and Advanced Memory Overclocking Features. A large watermark '第 4 頁' is overlaid on the table.



Enabling an Intelligent Planet

288Pin DDR5 5600 1.1V ECC-DIMM
 16GB Based on 2048Mx8
 AQD-D5V16GE56-SB

832	Profile3 :Module VPP Voltage Level		00
833	Module VDD Voltage Level		00
834	Module VDDQ Voltage Level		00
835	Module TBD Voltage Level - THIS BYTE IS CURRENTLY RSVD		00
836	Memory Controller Voltage Level		00
837	SDRAM Minimum Cycle Time (tCKAVGmin),Least Significant Byte		00
838	SDRAM Minimum Cycle Time (tCKAVGmin),Most Significant Byte		00
839	SDRAM CAS Latencies Supported,First Byte		00
840	SDRAM CAS Latencies Supported,Second Byte		00
841	SDRAM CAS Latencies Supported,Third Byte		00
842	SDRAM CAS Latencies Supported,Fourth Byte		00
843	SDRAM CAS Latencies Supported,Fifth Byte		00
844	RSVD for future CAS Latency		00
845	SDRAM Minimum CAS Latency Time (tAAmin),Least Significant Byte		00
846	SDRAM Minimum CAS Latency Time (tAAmin),Most Significant Byte		00
847	SDRAM Minimum RAS to CAS Delay Time (tRCDmin),Least Significant Byte		00
848	SDRAM Minimum RAS to CAS Delay Time (tRCDmin),Most Significant Byte		00
849	SDRAM Minimum Row Precharge Delay Time (tRPmin),Least Significant Byte		00
850	SDRAM Minimum Row Precharge Delay Time (tRPmin),Most Significant Byte		00
851	SDRAM Minimum Active to Precharge Delay Time (tRASmin),Least Significant Byte		00
852	SDRAM Minimum Active to Precharge Delay Time (tRASmin),Most Significant Byte		00
853	SDRAM Minimum Active to Active/Refresh Delay Time(tRCmin) ,Least Significant Byte		00
854	SDRAM Minimum Active to Active/Refresh Delay Time(tRCmin) ,Most Significant Byte		00
855	SDRAM Minimum Write Recovery Time (tWRmin),Least Significant Byte		00
856	SDRAM Minimum Write Recovery Time (tWRmin),Most Significant Byte		00
857	SDRAM Minimum Refresh Recovery Delay Time(tRFC1min),Least Significant Byte		00
858	SDRAM Minimum Refresh Recovery Delay Time(tRFC1min),Most Significant Byte		00
859	SDRAM Minimum Refresh Recovery Delay Time(tRFC2min),Least Significant Byte		00
860	SDRAM Minimum Refresh Recovery Delay Time(tRFC2min),Most Significant Byte		00
861	SDRAM Minimum Refresh Recovery Delay Time(tRFCsb),Least Significant Byte		00
862	SDRAM Minimum Refresh Recovery Delay Time(tRFCsbmin),Most Significant Byte		00
863-890	RSVD,must be coded as 0x00		00
891	Advanced Memory Overclocking Features		00
892	System CMD Rate Mode		00
893	Vendor Personality Byte - RSVD		00
894	Cyclical Redundancy Code (CRC) for Base Configuration Section, Least Significant Byte/for bytes 832-893		00
895	Cyclical Redundancy Code (CRC) for Base Configuration Section, Most Significant Byte/for bytes 832-893		00
896-1023	User Settings		00

第 5 頁

Note :

1. Byte 194-201 -- By SPD Hub & PMIC Vendor & Revision
 - 1.1 Byte 194-197 – RENESAS[(0x80), (0xB3), (0x80), (0x21)] ; MONTAGE[(0x86), (0x32), (0x80), (0x15)]
 - 1.2 Byte 198-201 – RENESAS[(0x80), (0xB3), (0x82), (0x20)] ; RICHTEK[(0x8A), (0x8C), (0x82), (0x11)]
2. Byte 514 -- Manufacturing location by manufacturing location
3. Byte 515 -- Module manufacturing date by year (YY). (Decimal)
4. Byte 516 -- Module manufacturing date by week (WW). (Decimal)
5. Bytes 517-520 -- Module Serial Number. (Decimal)
6. Bytes 521-550 -- Module Part Number. (ASCII format, unused digits are coded as ASCII blanks (0x20).
7. Bytes 552-553 -- DRAM Manufacturer ID Code by JEDEC definition. SAMSUNG :[(0x80) ,(0xCE)]
8. Bytes 555~639 -- These bytes are undefined and can be used own purpose