

ARES-5221B

Single arm wall-mount workstation

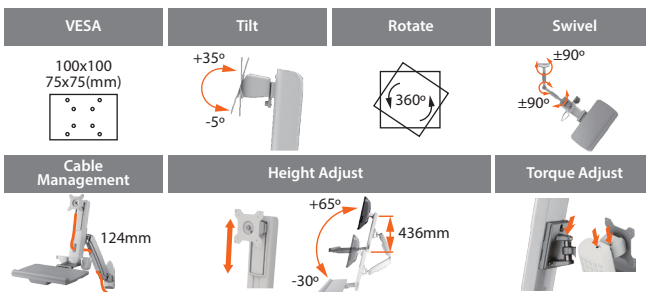

VESA 100x100/75x75 mm **MAX** 2 ~ 8 kg



Dimensions

Unit: mm

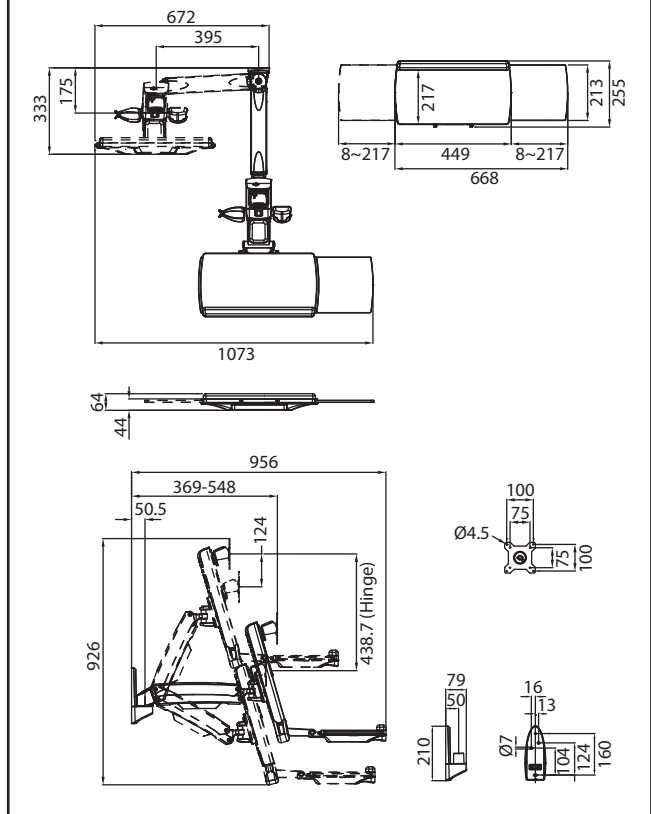

Specifications

Complete System	Net Weight	9.26 kg (20.42lbs)	
	Dimension (W x H x D)	956 x 926 x 333 mm (37.64" x 36.46" x 13.11")	
	Screw Type	M4	
	Material	Steel/Plastic/Aluminum	
Display System	Hinge Module	Swivel (VESA Hinge)	±90°
		Tilt (VESA Hinge)	-5° ~ +35°
		Tilt (Keyboard)	0 ~ 90°
		Pivot	360°
	Display Support	User Torque Adjust	Available
		Mounting Pattern	100x100 / 75x75 mm
		Display Type	Singal Monitor
		Panel Size Support	≤ 27"
	Height Adjust	Support Weight (VESA)	2~8kg (4.4~17.6lbs)
		Support Weight (Keyboard)	2.5kg(5.5lbs)
		Height Adjustment Range (Display & KeyBoard Tray) / (Arm)	124mm(4.88") / 436mm(17.27")
		Tension Torque Adjust	Yes
		Tilt (Arm)	- 30° ~ + 65°
Max.Working Space	449 x 207 mm (17.68" X 8.15") for Keyboard Tray		
Extended ArmProvided	1		
Cable Management	Yes		

Ordering Information

Part No.	Product Description
ARES-5221B-ORW1000	Workstation, support ≤ 27", 2 ~ 8 kg, single Arm with Keyboard tray, 75x75 / 100 x 100 mm

ARES-5221C

Dual arm wall-mount workstation



VESA 100x100/75x75 mm **MAX** 2 ~ 8 kg

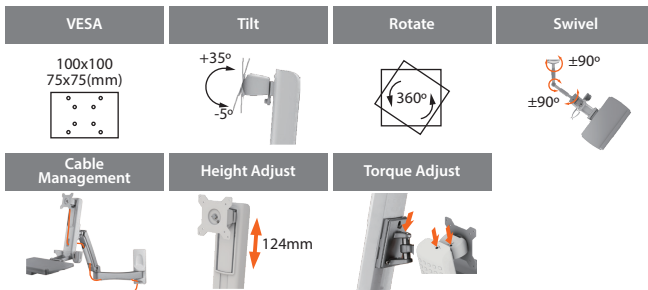

Dimensions

Unit: mm

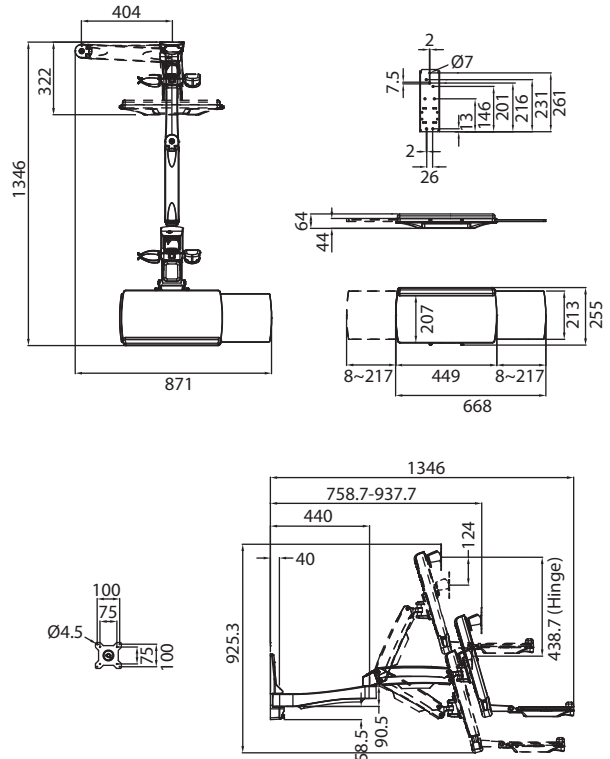

Specifications

Complete System	Net Weight	11.41 kg (25.16lbs)	
	Dimension (W x H x D)	1346 x 925.3 x 322 mm (52.99" x 36.43" x 12.68")	
	Screw Type	M4	
	Material	Steel/Plastic/Aluminum	
Display System	Hinge Module	Swivel (VESA Hinge)	±90°
		Tilt (VESA Hinge)	-5° ~ +35°
		Tilt (Keyboard)	0 ~ 90°
		Pivot	360°
		User Torque Adjust	Available
	Display Support	Mounting Pattern	100x100 / 75x75 mm
		Display Type	Singal Monitor
		Panel Size Support	≤ 27"
		Support Weight (VESA)	2~8kg (4.4~17.6lbs)
	Height Adjust	Support Weight (Keyboard)	2.5kg (5.5lbs)
		Height Adjustment Range (Display)	124mm (4.88") / 436mm (17.27")
		Tension Torque Adjust	Yes
		Tilt (Arm)	-30° ~ +65°
Max.Working Space	449 x 207 mm (17.68" X 8.15") for Keyboard Tray		
Extended Arm Provided	2		
Cable Management	Yes		

Ordering Information

Part No.	Product Description
ARES-5221C-ORW2000	Workstation, support ≤ 27", 2 ~ 8 kg, dual arm with Keyboard tray, 75x75 / 100 x 100 mm

ARES-52210

Single arm wall-mount workstation



VESA 100x100/75x75 mm **MAX** 2 ~ 8 kg

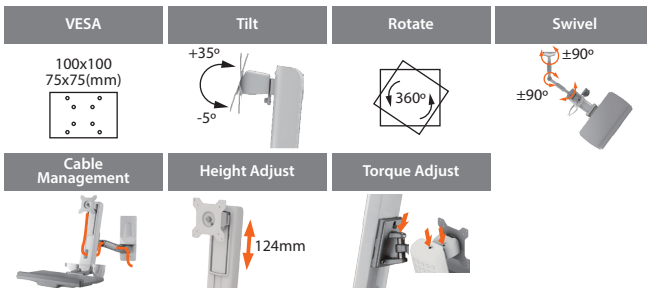

Dimensions

Unit: mm

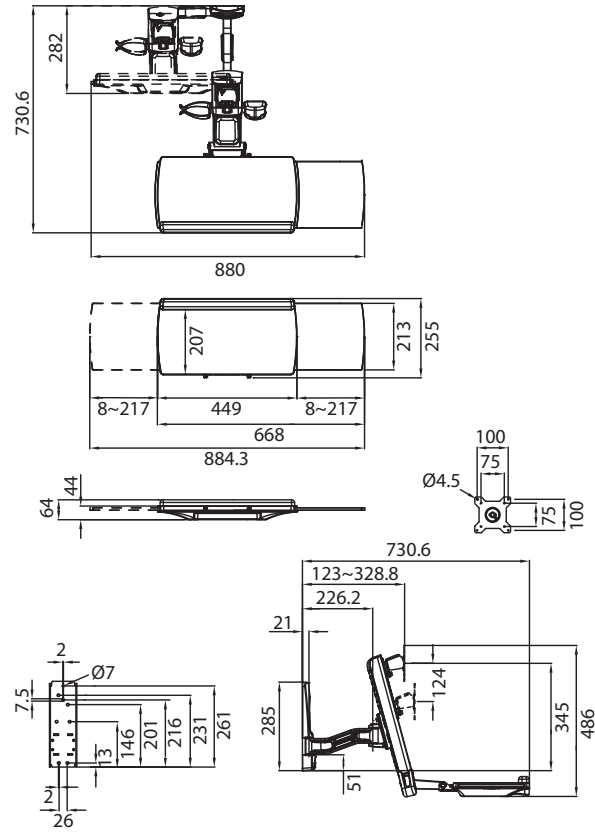

Specifications

Complete System	Net Weight	7.11 kg (15.68lbs)	
	Dimension (W x H x D)	730.6 x 486 x 282 mm (28.76" x 19.13" x 11.10")	
	Screw Type	M4	
	Material	Steel/Plastic/Aluminum	
Display System	Hinge Module	Swivel (VESA Hinge)	±90°
		Tilt (VESA Hinge)	-5° ~ +35°
		Tilt (Keyboard)	0 ~ 90°
		Pivot	360°
		User Torque Adjust	Available
	Display Support	Mounting Pattern	100x100 / 75x75 mm
		Display Type	Singal Monitor
		Panel Size Support	≤ 27"
		Support Weight (VESA)	2~8kg (4.41~17.64lbs)
	Height Adjust	Support Weight (Keyboard)	2.5kg (5.5lbs)
		Height Adjustment Range (Display)	124mm (4.88")
		Tension Torque Adjust	Yes
		Tilt (Arm)	N/A
		Max.Working Space	449 x 207 mm (17.68" X 8.15") for Keyboard Tray
Extended Arm	Provided	1	
Cable Management		Yes	

Ordering Information

Part No.	Product Description
ARES-52210-OEW1000	Workstation, 75x75 / 100x100 mm, ≤ 27", support 2 ~ 8kg, single arm w/KB tray

ARES-5112D

Rail wall-mount workstation



VESA 100x100/75x75 mm **MAX** 2 ~ 10 kg

VESA	Tilt	Rotate	Swivel
100x100 75x75(mm) 	+90° -20°	 360°	 ±90°
Cable Management	Height Adjust	Torque Adjust	
	+65° -30°		

Dimensions

Unit: mm

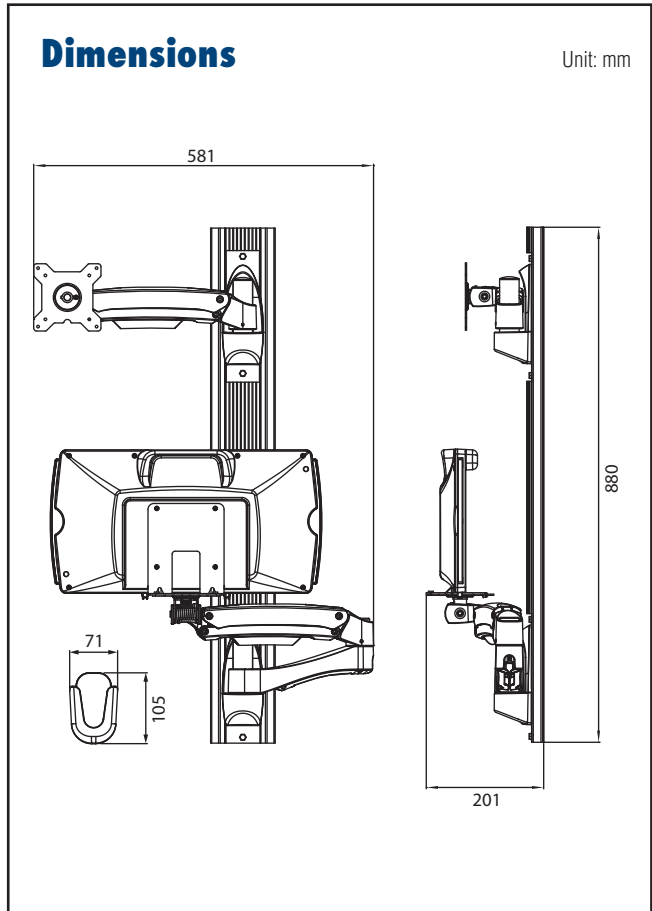

Specifications

Complete System	Net Weight	10.10 kg (22.27lbs)	
	Dimension (W x H x D)	581 x 880 x 201 mm (22.87" x 34.65" x 7.91")	
	Screw Type	M4	
	Material	Steel/Aluminum Alloy/Plastic	
Display System	Hinge Module	Swivel (Hinge)	±90°
		Tilt (Hinge)	-20° ~ + 90°
		Tilt (Keyboard)	0 ~ 90°
		Pivot	360°
		User Torque Adjust	Available
	Display Support	Mounting Pattern	100x100 / 75x75 mm
		Display Type	Singal Monitor
		Panel Size Support	≤ 32"
		Support Weight (Arm)	2 ~ 10 kg
	Height Adjust	Support Weight (Keyboard)	2.5kg (5.5lbs)
		Height Adjustment Range (Display)	315 mm (12.40")
		Tension Torque Adjust	Yes
		Tilt (Arm)	-30° ~ + 65°
Max.Working Space	449 x 207 mm (17.68" X 8.15") for Keyboard Tray		
Extended Arm Provided	1 / 2		
Cable Management	Yes		

Ordering Information

Part No.	Product Description
ARES-5112D-W881200	Workstation, 75x75 / 100x100 mm, support ≤ 32", 2 ~ 10 kg, rail tray with Keyboard tray

ARES-5223D

Single arm dual display wall-mount workstation



VESA 100x100/75x75 mm **MAX** 6 ~ 12 kg

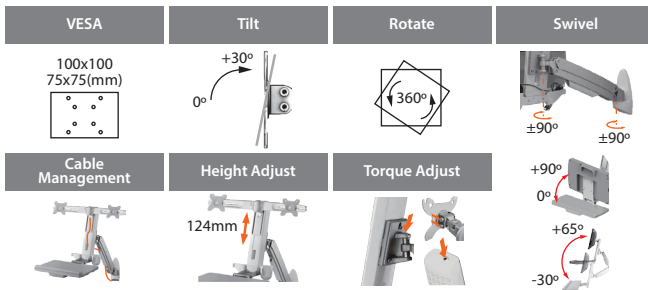

Dimensions

Unit: mm

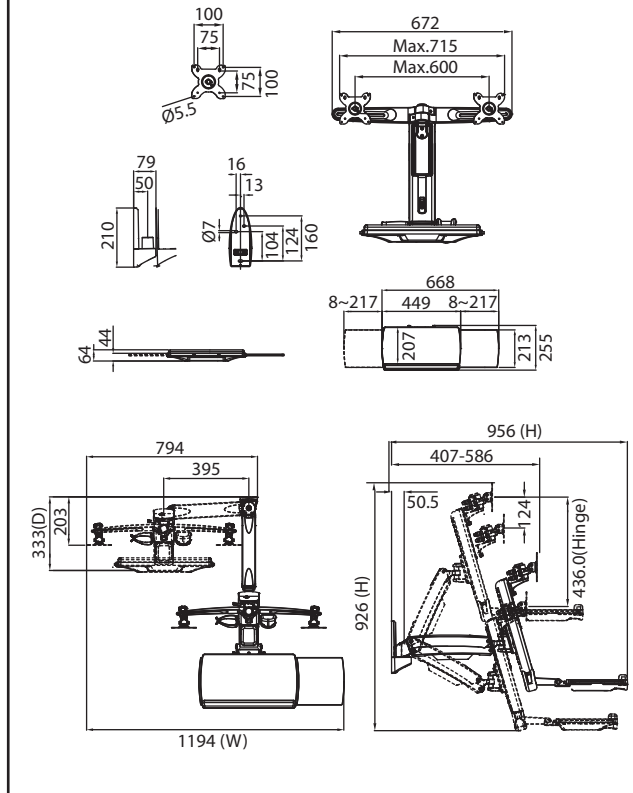

Specifications

Complete System	Net Weight	11.8kg (26.01lbs)	
	Dimension (W x H x D)	1194 x 995 x 956 mm (47" x 39.17" x 37.64")	
	Screw Type	M4	
	Material	Steel/Plastic/Aluminum	
Display System	Hinge Module	Swivel (VESA Hinge)	±90°
		Tilt (VESA Hinge)	0 ~ 30°
		Tilt (Keyboard)	0 ~ 90°
		Pivot	360°
	Display Support	User Torque Adjust	Available
		Mounting Pattern	100x100 / 75x75 mm
		Display Type	Dual Monitor
		Panel Size Support	≤ 24"
	Height Adjust	Support Weight (VESA*2 Total)	6 ~ 12kg (13.2 ~ 26.5.6lbs)
		Support Weight (Keyboard)	2.5kg (5.5lbs)
		Height Adjustment Range (Display) / (Arm)	124mm (4.88") / 436mm (17.27")
		Tension Torque Adjust	Yes
		Tilt (Arm)	-30° ~ + 65°
		Max. Distance To TheWall	449 x 207 mm (17.68" X 8.15") for Keyboard Tray
Extended Arm Provided	1		
Cable Management	Yes		

Ordering Information

Part No.	Product Description
ARES-5223D-W12EM00	Workstation, ≤ 24", support 6 ~ 12kg, dual display, w/KB tray, 75x75 / 100x100 mm

ARES-5221T

Accessories, Keyboard plate



100x100/75x75 mm



6 ~ 12 kg

Height Adjust

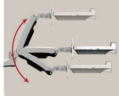

Lateral Mode



Retractable



Easy to be cleaned



Dimensions

Unit: mm

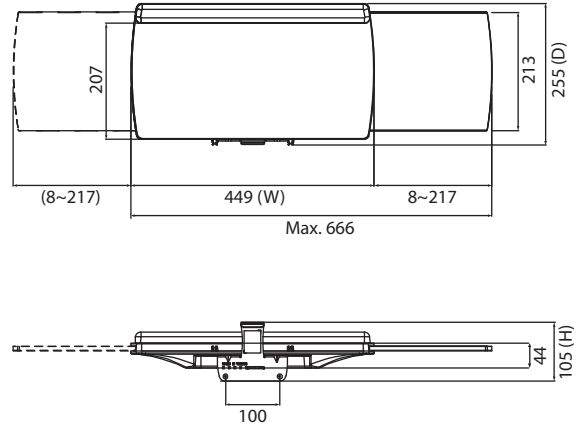

Specifications

Complete System	Net Weight	2.05 kg (4.52lbs)
	Dimension (W x H x D)	449 x 105 x 255 mm (17.67" x 4.13" x 10.04")
	Material	Steel/Plastic
	Screw Type	M4
	Support Weight (Max.)	2.5 Kg (5.51 lbs)
	Max.Working Space	449 x 207 mm (17.68" x 8.15") for keyboard tray





Ordering Information

Part No.	Product Description
ARES-5221T-AOK0100	Keyboard plate only, max. support 2.5kg, with mounting bracket 100mm, no other mechanical parts

Compatible Table



Get the latest version [HERE](#)

Model Name	ARES-5221C			ARES-5221O		ARES-5112D	ARES-5221B	ARES-5223D
Part Number	ARES-5221C-ORW2000			ARES-5221O-OEW1000		ARES-5112D-W881200	ARES-5221B-ORW1000	ARES-5223D-W12EM00
Photo								
Max. support weight	2-8kg			2-8kg		2 ~ 10kg	2-8kg	6 ~ 12kg
Max. support panel size	≤ 27"			≤ 27"		≤ 32"	≤ 27"	≤ 24"
System Model	Panel size (inch)	Weight (kg)	VESA (mm)	75 x 75 mm 100 x 100 mm	75 x 75 mm 100 x 100 mm	75 x 75 mm 100 x 100 mm	75 x 75 mm 100 x 100 mm	75 x 75 mm 100 x 100 mm
FPM-212	12.1"	3.2	75 x 75	-	-	-	-	-
FPM-215	15"	4.6	75 x 75	-	-	-	-	-
FPM-217	17"	5.4	75 x 75	-	-	-	-	-
FPM-219	19"	6.2	75 x 75	-	-	-	-	-
FPM-3121G	12.1"	4.07	75 x 75 100 x 100	-	-	-	-	-
FPM-3151G	15"	7.73	75 x 75 100 x 100	-	-	-	-	-
FPM-3171G	17"	9.25	75 x 75 100 x 100	-	-	-	-	-
FPM-3191G	19"	10.65	75 x 75 100 x 100	-	-	-	-	-
FPM-5151G	15"	6	75 x 75 100 x 100	-	-	-	-	-
FPM-5171G	17"	7	75 x 75 100 x 100	-	-	-	-	-
FPM-5191G	19"	9	75 x 75 100 x 100	-	-	-	-	-
FPM-7151T	15"	4.2	75 x 75 100 x 100	-	-	-	-	-
FPM-7151W	15.6"	4.2	75 x 75 100 x 100	-	-	-	-	-
FPM-715	15"	4.6	75 x 75	-	-	-	-	-
FPM-715W	15.6"	4	75 x 75	-	-	-	-	-
FPM-717	17"	5.4	75 x 75	-	-	-	-	-
FPM-7181W	18.5"	6	100 x 100	-	-	-	-	-
FPM-719	19"	6.2	75 x 75	-	-	-	-	-
FPM-7211W	21.5"	8	100 x 100	-	-	-	-	-
FPM-815S	15"	7.73	100 x 100	-	-	-	-	-
FPM-817S	17"	7.73	100 x 100	-	-	-	-	-
FPM-8151H	15"	8.5	75 x 75 100 x 100	-	-	-	-	-
HIT-507	7"	1.2	75 x 75	-	-	Yes	-	-
HIT-512	11.6"	1.5	75 x 75	-	-	Yes	-	-
HIT-W101L	10.1"	1.4	75 x 75	-	-	Yes	-	-
HIT-W153	15.6"	4.7	75 x 75 100 x 100	Yes	Yes	Yes	Yes	-
HIT-W183	18.5"	5.94	75 x 75 100 x 100	Yes	Yes	Yes	Yes	-
IPPC-5211WS	21.5"	15.8	100 x 100	-	-	-	-	-
PAX-121	21.5"	5.5	75 x 75 100 x 100	Yes	Yes	Yes	Yes	Yes
PAX-124	23.8"	6.98	75 x 75 100 x 100	Yes	Yes	Yes	Yes	Yes
PAX-324	24"	7.6	75 x 75 100 x 100	Yes	Yes	Yes	Yes	Yes
PAX-327	27"	10.36	75 x 75 100 x 100	-	-	-	-	Yes
PAX-332	32"	12.5	75 x 75 100 x 100	-	-	-	-	-
PAX-355	55"	55	600x400	-	-	-	-	-
POC-421	21.5"	6.29	75 x 75 100 x 100	Yes	Yes	Yes	Yes	Yes

Compatible Table



Get the latest version [HERE](#)

Model Name	ARES-5221C			ARES-5221O		ARES-5112D	ARES-5221B	ARES-5223D
Part Number	ARES-5221C-ORW2000			ARES-5221O-OEW1000		ARES-5112D-W881200	ARES-5221B-ORW1000	ARES-5223D-W12EM00
Photo								
Max. support weight	2-8kg			2-8kg		2-10kg	2-8kg	6-12kg
Max. support panel size	≤ 27"			≤ 27"		≤ 32"	≤ 27"	≤ 24"
System Model	Panel size (inch)	Weight (kg)	VESA (mm)	75 x 75 mm 100 x 100 mm	75 x 75 mm 100 x 100 mm	75 x 75 mm 100 x 100 mm	75 x 75 mm 100 x 100 mm	75 x 75 mm 100 x 100 mm
POC-424	23.8"	7.78	75 x 75 100 x 100	Yes	Yes	Yes	Yes	Yes
POC-615	15.6"	4.89	75 x 75 100 x 100	Yes	Yes	Yes	Yes	-
POC-621	21.5"	6.29	75 x 75 100 x 100	Yes	Yes	Yes	Yes	Yes
POC-624	23.8"	7.78	75 x 75 100 x 100	Yes	Yes	Yes	Yes	Yes
POC-821	21.5"	7	75 x 75 100 x 100	Yes	Yes	Yes	Yes	Yes
POC-824	23.8"	8	75 x 75 100 x 100	Yes	Yes	Yes	Yes	Yes
SPC-221	21.5"	9	100 x 100	-	-	-	-	-
SPC-515	15"	10	100 x 100	-	-	-	-	-
SPC-815 (VESA mounting kit: 9653800M020)	15.6"	8.2	100 x 100	-	-	-	-	-
SPC-821 (VESA mounting kit: 9653800M020)	21.5"	10.6	100 x 100	-	-	-	-	-
TPC-1251T	12"	3.12	100 x 100	-	-	-	-	-
TPC-1551T	15"	4.4	100 x 100	-	-	-	-	-
TPC-1751T	17"	5.1	100 x 100	-	-	-	-	-
TPC-312 WHL	12.1"	4.1	100 x 100	-	-	-	-	-
TPC-315 WHL	15"	5.8	100 x 100	-	-	-	-	-
TPC-317 WHL	17"	6.1	100 x 100	-	-	-	-	-
TPC-324W WHL	23.8"	9.3	100 x 100	-	-	-	-	-
TPC-312 EHL	12"	4.1	100 x 100	-	-	-	-	-
TPC-315 EHL	15"	5.8	100 x 100	-	-	-	-	-
TPC-324W EHL	23.8"	9.3	100 x 100	-	-	-	-	-
TPC-107W	7"	2	100 x 100	-	-	-	-	-
TPC-110W	10.1"	3.9	100 x 100	-	-	-	-	-
TPC-115W	15.6"	6.9	100 x 100	-	-	-	-	-
UTC-115	15.6"	2.4	100 x 100	Yes	Yes	Yes	Yes	-
UTC-120	21.5"	5.29	100 x 100	Yes	Yes	Yes	Yes	-
UTC-307	7"	0.95	75 x 75	-	-	-	-	-
UTC-310	10.1"	1.12	75 x 75	-	-	-	-	-
UTC-315	15.6"	<4	75 x 75	Yes	Yes	Yes	Yes	-
UTC-318	18.5"	5	100 x 100	Yes	Yes	Yes	Yes	-
UTC-320	21.5"	6.5	100 x 100	Yes	Yes	Yes	Yes	Yes
UTC-510	10.1"	1.8	75 x 75	-	-	-	-	-
UTC-515	15.6"	4.85	100 x 100	Yes	Yes	Yes	Yes	-
UTC-520	21.5"	8	100 x 100	Yes	Yes	Yes	Yes	Yes
UTC-532	31.5"	18	100 x 100	-	-	-	-	-
UTC-542	42.5"	24.6	100 x 100	-	-	-	-	-
UTC-722	21.5"	16	200 x 200	-	-	-	-	-
UTC-723	31.5"	38	200 x 200	-	-	-	-	-
UTK-615AP	15.6"	5	100 x 100	Yes	Yes	Yes	Yes	-
UTK-615DP	15.6"	5	100 x 100	Yes	Yes	Yes	Yes	-

ARES-5252G

Single Arm Wall-Mount Workstation Patented VESA Bracket



VESA 100x100/75x75 mm **MAX** 2 ~ 10 kg Color Options:

Dimensions

Unit: mm

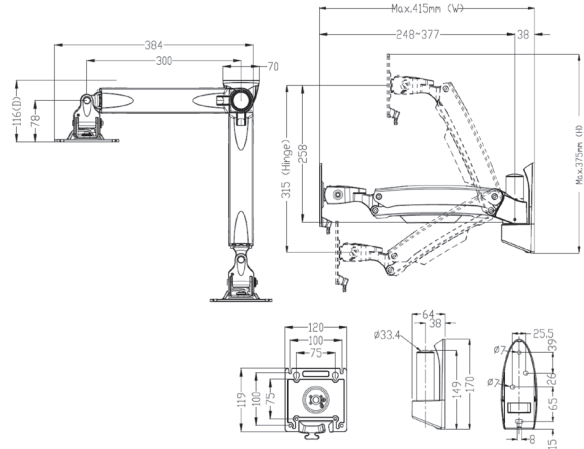

Specifications

Complete System	Net Weight	1.70 Kg (3.75lbs)	
	Dimension (W x H x D)	415 x 375 x 116mm (16.34" x 14.76" x 4.57")	
	Screw Type	M4	
	Material	Steel/Aluminum Alloy/Plastic	
Display System	Hinge Module	Swivel (Hinge)	±90°
		Tilt (Hinge)	-20° ~ + 90°
		Pivot	360°
		User Torque Adjust	Available
	Display Support	Mounting Pattern	100x100 / 75x75 mm
		Panel Size Support	≤ 32"
		Support Weight (Range)	2~10Kg (4.41~22.05lbs)
	Height Adjust	Height Adjustment Range (Arm)	315 mm (12.4")
		Tension Torque Adjust	Yes
		Tilt (Arm)	-30° (down) ~ +65° (up)
Max. Distance To TheWall	415mm (16.34")		
Min. Distance To TheWall	99mm (3.90")		
Extended ArmProvided	1		
Cable Management	Yes		

Ordering Information

Part No.	Description
ARES-5252G-ATW1000	WallArm, patented VESA, ≤ 32", support 2~10 kg

ARES-52A2G

Extended Arm Wall-Mount Workstation Patented VESA Bracket

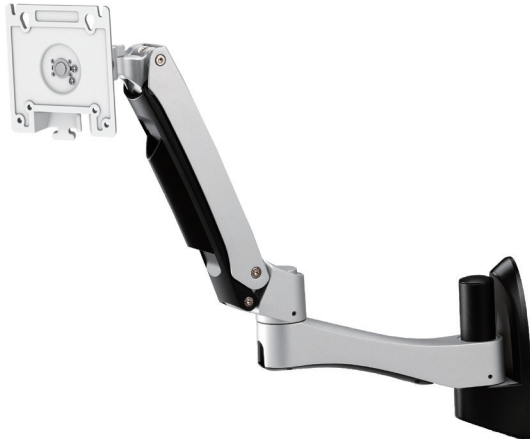

Dimensions

Unit: mm

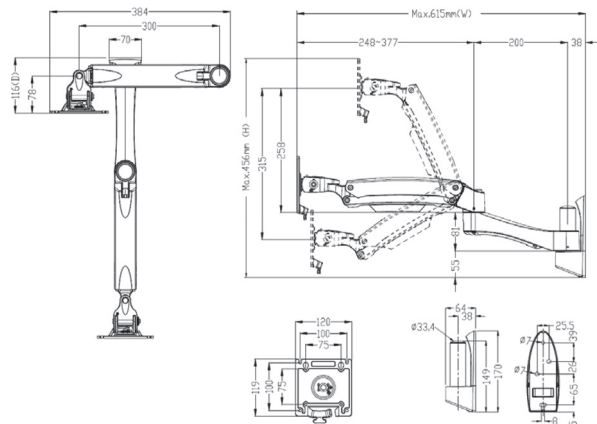

100x100/75x75 mm



2 ~ 10 kg

Color Options:

Specifications

Complete System	Net Weight	2.10 kg (4.63 lbs)		
	Dimension (W x H x D)	615 x 456 x 116 mm (24.21" x 17.95" x 4.57")		
	Screw Type	M4		
	Material	Steel/Aluminum Alloy/Plastic		
Display System	Hinge Module	Swivel (Hinge)	±90°	
		Tilt (Hinge)	-20° ~ + 90°	
		Pivot	360°	
		User Torque Adjust	Available	
	Display Support	Mounting Pattern	100x100 / 75x75 mm	
		Panel Size Support	≤ 32"	
		Support Weight (Range)	2~10Kg (4.41~22.05lbs)	
	Height Adjust	Height Adjustment Range (Arm)	315 mm (12.4")	
		Tension Torque Adjust	Yes	
		Tilt (Arm)	-30° (down) ~ +65° (up)	
Max. Distance To TheWall	615mm (24.21")			
Min. Distance To TheWall	99 mm (3.90")			
Extended ArmProvided	2			
Cable Management	Yes			

Ordering Information

Part No.	Description
ARES-52A2G-ATW2000	WallArm, patented VESA, ≤ 32", support 2~10 kg

Compatible Table

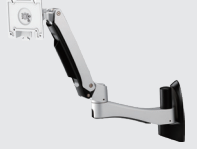

Get the latest version [HERE](#)

Model Name				ARES-5252G	ARES-52A2G
Part Number				ARES-5252G-ATW1000	ARES-52A2G-ATW2000
Photo					
Max. Support Weight				2-10kg	2-10kg
Max. Support Panel Size				≤ 32	≤ 32
System Model	Panel size (inch)	Weight (kg)	VESA (mm)	75 x 75 mm 100 x 100 mm	75 x 75 mm 100 x 100 mm
FPM-1150G	15	4	75 x 75	Yes	Yes
FPM-115W	15.6	1.5	100 x 100	-	-
FPM-121W	21.5	2.5	100 x 100	Yes	Yes
FPM-212	12.1	3.2	75 x 75	Yes	Yes
FPM-215	15	4.6	75 x 75	Yes	Yes
FPM-215W	15.6	4	75 x 75	Yes	Yes
FPM-217	17	5.4	75 x 75	Yes	Yes
FPM-219	19	6.2	75 x 75	Yes	Yes
FPM-221W	21.5	6	75 x 75	Yes	Yes
FPM-3121G	12.1	4.07	75 x 75 100 x 100	Yes	Yes
FPM-3151G	15	7.73	75 x 75 100 x 100	Yes	Yes
FPM-3171G	17	9.25	75 x 75 100 x 100	Yes	Yes
FPM-3191G	19	10.65	75 x 75 100 x 100	-	-
FPM-5151G	15	6	75 x 75 100 x 100	Yes	Yes
FPM-5171G	17	7	75 x 75 100 x 100	Yes	Yes
FPM-5191G	19	9	75 x 75 100 x 100	Yes	Yes
FPM-7061	6.5	1.2	75 x 75	-	-
FPM-7121	12.1	2.6	75 x 75 100 x 100	Yes	Yes
FPM-715	15	4.6	75 x 75	Yes	Yes
FPM-7151T	15	4.2	75 x 75 100 x 100	Yes	Yes
FPM-7151W	15.6	4.2	75 x 75 100 x 100	Yes	Yes
FPM-715W	15.6	4	75 x 75	Yes	Yes
FPM-717	17	5.4	75 x 75	Yes	Yes
FPM-7181W	18.5	6	100 x 100	Yes	Yes
FPM-719	19	6.2	75 x 75	Yes	Yes
FPM-7211W	21.5	8	100 x 100	Yes	Yes
FPM-7212	21.5		75 x 75 100 x 100	Yes	Yes
FPM-8151H	15	8.5	75 x 75 100 x 100	Yes	Yes
FPM-815S	15	7.73	100 x 100	Yes	Yes
FPM-817S	17	7.73	100 x 100	Yes	Yes
HIT-507	7	1.2	75 x 75	-	-
HIT-512	11.6	1.5	75 x 75	-	-
HIT-W101L	10.1	1.4	75 x 75	-	-
HIT-W153	15.6	4.7	75 x 75mm 100 x 100	Yes	Yes
HIT-W183	18.5	5.94	75 x 75mm 100 x 100	Yes	Yes
HIT-312	11.6	1.2	100 x 100	-	-
HIT-315	15.6	1.2	100 x 100	-	-
IDS-3118W	18.5	4.69	75 x 75 100 x 100	Yes	Yes
IDS-3121W	21.5	5.4	75 x 75 100 x 100	Yes	Yes
IDS-3217	17		75 x 75 100 x 100	Yes	Yes
IDS-3218W	18.5	5	75 x 75 100 x 100	Yes	Yes
IPPC-5211WS	21.5	15.8	100 x 100	-	-
PAX-121	21.5	5.5	75 x 75 100 x 100	Yes	Yes

Compatible Table

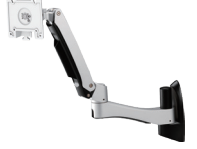

Get the latest version [HERE](#)

Model Name				ARES-5252G	ARES-52A2G
Part Number				ARES-5252G-ATW1000	ARES-52A2G-ATW2000
Photo					
Max. Support Weight				2-10kg	2-10kg
Max. Support Panel Size				≤ 32	≤ 32
System Model	Panel size (inch)	Weight (kg)	VESA (mm)	75 x 75 mm 100 x 100 mm	75 x 75 mm 100 x 100 mm
PAX-124	23.8	6.98	75 x 75 100 x 100	Yes	Yes
PAX-324	24	7.6	75 x 75mm 100 x 100	Yes	Yes
PAX-327	27	10.36	75 x 75mm 100 x 100	-	-
PAX-332	32	12.5	75 x 75mm 100 x 100	-	-
PAX-355	55	55	600 x 400mm	-	-
POC-421	21.5	6.29	75 x 75mm 100 x 100	Yes	Yes
POC-424	23.8	7.78	75 x 75mm 100 x 100	Yes	Yes
POC-615	15.6	4.89	75 x 75mm 100 x 100	Yes	Yes
POC-621	21.5	6.29	75 x 75mm 100 x 100	Yes	Yes
POC-624	23.8	7.78	75 x 75mm 100 x 100	Yes	Yes
POC-821	21.5	7	75 x 75mm 100 x 100	Yes	Yes
POC-824	23.8	8	75 x 75mm 100 x 100	Yes	Yes
PPC-112W	11.6	1.78	100 x 100	-	-
PPC-115W	15.6	2.6	100 x 100	Yes	Yes
PPC-3060S	6.5 / 7	1.5	75 x 75	-	-
PPC-3100	10.4	2.8	75 x 75	Yes	Yes
PPC-3120	12.1	3.4	75 x 75	Yes	Yes
PPC-3150	15	5.3	75 x 75	Yes	Yes
PPC-3150S	15	4	75 x 75	Yes	Yes
PPC-3150SW	15.6	4.7	75 x 75	Yes	Yes
PPC-3151	15	5.4	75 x 75	Yes	Yes
PPC-315SW	15.6	4.8	100 x 100	Yes	Yes
PPC-315W	15.6	4.8	100 x 100	Yes	Yes
PPC-3170	17	6.3	75 x 75	Yes	Yes
PPC-3180	18.5	5.4	75 x 75	Yes	Yes
PPC-3181SW	18.5	5.7	100 x 100	Yes	Yes
PPC-3190	19	7	75 x 75	Yes	Yes
PPC-3210SW	21.5	7.5	75 x 75	Yes	Yes
PPC-3211SW	21.5	6.8	100 x 100	Yes	Yes
PPC-3211W	21.5	7.7	75 x 75 100 x 100	Yes	Yes
PPC-321W EHL	21.5	7.2	75 x 75	Yes	Yes
PPC-321W TGL	21.5	6.6	100 x 100	Yes	Yes
PPC-3241SW	23.8	8.6	100 x 100	Yes	Yes
PPC-324W	23.8	8.4	100 x 100	Yes	Yes
PPC-324W P7	23.8	8.6	100 x 100	Yes	Yes
PPC-412	12.1	3.4	75 x 75	Yes	Yes
PPC-415 TBG	15	5.4	75 x 75	Yes	Yes
PPC-6121	12.1	3.8	75 x 75	Yes	Yes
PPC-6151C	15	5.03	75 x 75 100 x 100	Yes	Yes
PPC-615W	15.6	6.1	75 x 75	Yes	Yes
PPC-6171C	17	5.4	75 x 75 100 x 100	Yes	Yes
PPC-618W	18.5	7.6	75 x 75 100 x 100	Yes	Yes
PPC-6191C	19	5.8	75 x 75 100 x 100	Yes	Yes
PPC-621W	21.5	8.4	75 x 75 100 x 100	Yes	Yes
SPC-221	21.5	9	100 x 100	Yes	Yes

Compatible Table

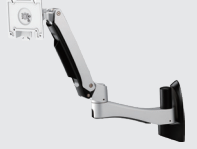

Get the latest version [HERE](#)

Model Name	ARES-5252G			ARES-52A2G		
Part Number	ARES-5252G-ATW1000			ARES-52A2G-ATW2000		
Photo						
Max. Support Weight	2-10kg			2-10kg		
Max. Support Panel Size	≤ 32			≤ 32		
System Model	Panel size (inch)	Weight (kg)	VESA (mm)	75 x 75 mm 100 x 100 mm	75 x 75 mm 100 x 100 mm	
SPC-515	15	10	100 x 100	Yes	Yes	
SPC-815 (VESA mounting kit: 9653800M020)	15.6	8.2	100 x 100	Yes	Yes	
SPC-821 (VESA mounting kit: 9653800M020)	21.5	10.6	100 x 100	-	-	
TPC-107W	7	2	100 x 100	Yes	Yes	
TPC-110W	10.1	3.9	100 x 100	Yes	Yes	
TPC-115W	15.6	6.9	100 x 100	Yes	Yes	
TPC-1251T	12	3.12	100 x 100	Yes	Yes	
TPC-1551T	15	4.4	100 x 100	Yes	Yes	
TPC-1751T	17	5.1	100 x 100	Yes	Yes	
TPC-312 EHL	12	4.1	100 x 100	Yes	Yes	
TPC-312 WHL	12.1	4.1	100 x 100	Yes	Yes	
TPC-315 EHL	15	5.8	100 x 100	Yes	Yes	
TPC-315 WHL	15	5.8	100 x 100	Yes	Yes	
TPC-317 WHL	17	6.1	100 x 100	Yes	Yes	
TPC-324W EHL	23.8	9.3	100 x 100	Yes	Yes	
TPC-324W WHL	23.8	9.3	100 x 100	Yes	Yes	
USC-130	11.6	2	75 x 75 (embedded)	-	-	
USC-160	15.6	3	75 x 75	Yes	Yes	
USC-250	15	5.1	75 x 75 (embedded)	-	-	
USC-M3	11.6	2	75 x 75 (embedded)	-	-	
USC-M6	15.6	3	75 x 75 (embedded)	-	-	
UTC-115	15.6	2.4	100 x 100	Yes	Yes	
UTC-120	21.5	5.29	100 x 100	Yes	Yes	
UTC-124	23.8	6.53	100 x 100	Yes	Yes	
UTC-307	7	0.95	75 x 75	-	-	
UTC-310	10.1	1.12	75 x 75	-	-	
UTC-315	15.6	<4	75 x 75	Yes	Yes	
UTC-318	18.5	5	100 x 100	Yes	Yes	
UTC-320	21.5	6.5	100 x 100	Yes	Yes	
UTC-510	10.1	1.8	75 x 75	-	-	
UTC-515	15.6	4.85	100 x 100	Yes	Yes	
UTC-520	21.5	8	100 x 100	Yes	Yes	
UTC-532	31.5	18	200 x 200	-	-	
UTC-542	42.5	24.6	200 x 200	-	-	
UTC-723	31.5	38	200 x 200	-	-	
UTK-6023	23.8	38	200 x 200	-	-	
UTK-6031	31.5	40	200 x 200	-	-	
UTK-615AP	15.6	5	100 x 100	Yes	Yes	
UTK-615DP	15.6	5	100 x 100	Yes	Yes	
VUE-2101-WX50PA-A4	10.1	1.5	100 x 100	-	-	
VUE-2101-WX50PC-A4	10.1	1.5	100 x 100	-	-	
VUE-2101-WX50PX-A4	10.1	1.5	100 x 100	-	-	
VUE-2150-XA50PA-N4	15.0	3.5	100 x 100	Yes	Yes	
VUE-2150-XA50PC-N4	15.0	3.5	100 x 100	Yes	Yes	
VUE-2150-XA50PX-N4	15.0	3.5	100 x 100	Yes	Yes	
VUE-2156-FD45PA-N4	15.6	3.1	100 x 100	Yes	Yes	
VUE-2156-FD45PC-N4	15.6	3.1	100 x 100	Yes	Yes	
VUE-2156-FD45PX-N4	15.6	3.1	100 x 100	Yes	Yes	
VUE-2190	19	4.4	100 x 100	Yes	Yes	
VUE-2238-FD35PA-N4	23.8	6.2	100 x 100	Yes	Yes	
VUE-2238-FD35PC-N4	23.8	6.2	100 x 100	Yes	Yes	
VUE-2238-FD35PX-N4	23.8	6.2	100 x 100	Yes	Yes	
VUE-2320	32	10.35	200 x 200	-	-	