

ARK-2252

Intel® Core™ Ultra Series 3 PTL processors Fanless Box PC

Preliminary



Features

- Intel® Core Ultra Panther Lake Processor
- DDR5-6400/7200 CSODIMM memory support up to 128GB
- M.2 E Key, B Key and M Key for storage and wireless module installation
- Up to 4 x Intel GbE, 6 x serial ports, 8-bit DIO, 2xCANBus
- TPM on board for system security
- 3 displays with 2 x 4K HDMI, 1x4K typeC
- 4 x USB 3.2 and 2 x USB 2.0
- 12V~24V wide range power input
- 20 ~ 60 °C extended operating temperature
- Support Advantech iDoor, POE module
- Support Edge AI SDK, WEDA



Specifications

Processor System	CPU	Intel® Core™ Ultra 7 - 358H (12Xe)	Intel® Core™ Ultra 5 - 325 (4Xe)
	Frequency	1.9GHz up to 4.8GHz	2.1GHz up to 4.5GHz
	Core Number	16	8
	BIOS	AMI EFI 512 Mbit	
	AI Capability	Up to 180 TOPS	Up to 95 TOPS
Memory	Technology	DDR5 6400/7200 MT/s CSODIMM	DDR5 6400 MT/s CSODIMM
	Max capacity	Up to 128 GB	
	Socket	2x 262-pin SODIMM (no support ECC)	
Graphics	Chipset	Intel® Xe 3 LPG up to 192EU (12Xe) Intel® Xe 3 LPG (4Xe)	
	HDMI	2x HDMI 2.1 TMDs: 3840x2160@ 60Hz	
	TypeC DP	1x DP via USB Type C Alt mode: 3840x2160@ 60Hz	
	Triple Display	2 x HDMI + 1 x Type C DP	
Ethernet	LAN1	10/100/1000/2500 Mbps Intel i226V GbE, support Wake On LAN	
	LAN2	10/100/1000/2500 Mbps Intel i226V GbE, support Wake On LAN	
	LAN3	10/100/1000/2500 Mbps Intel i226V GbE, support Wake On LAN, support PoE module	
	LAN4	10/100/1000/2500 Mbps Intel i226V GbE, support Wake On LAN, support PoE module	
Audio	Interface	1x, (Mic-in or Line-out, by Realtek ALC888S, modified by OS)	
I/O Interface	Serial Ports	2 x RS232/422/485 (default: RS-232, default support High speed COM), modified by BIOS 4 x RS232/485 (6 wires), (default: RS-485) modified by Jumper and BIOS	
	USB Ports Type A	4 x USB3.2 Gen2 (w. Cable locking mechanism) 2 x USB2.0 (w. Cable locking mechanism) 1 x internal USB 2.0 Type A for security dongle (cannot co-exist w/ iDoor)	
	USB Port Type C	1x USB Type C w/ USB4, DP alt mode, 5V-3A	
	GPIO	8-bit Programmable DIO	
	CANBus	2x CANBus 2.0	
	Expansion	M.2	3x, 1 x Key-B 3042/ 3052 (PCIe Gen4 x2, USB3.2) w. 1 x with nano SIM holder, for 5G/AI/iDoor module 1 x Key-E 2230 (PCIe Gen4 x1, USB2.0) for WiFi Module 1 x Key-M 2280 (PCIe Gen5 x4)
Storage	NVMe	Default: 1x M.2 2280 M key (PCIe Gen5 x4) Optional: 1x M.2 2242 B key (PCIe Gen4x2) (modified by Switch)	
Other	WatchDog Timer	255 levels timer interval, setup by software	
	TPM	TPM2.0, NPCT764AAEYX FW7.2.4.1	
Software Support	Microsoft Windows	Windows 11 (LTSC)	
	Linux	by project support	
Power Requirement	Power Type	ATX/AT (default ATX)	
	Power Input Voltage	12-24 V _{DC}	
Power Consumption	Typical (OS idle mode)	TBD	
	Max. (Full loading)	TBD	
Mechanical	Construction	Aluminum housing	
	Mounting	DIN-rail/Wall Mount/VESA Mount	
	Dimensions (W x H x D)	260 x 60 x 145 mm	
	Weight	2.675 kg	
Environment	Operating Temperature	With extended temp. peripherals: -20 ~ 60° C with 0.7m/s air flow	
	Storage Temperature	-40 ~ 85 °C (-40 ~ 185°F)	
	Relative Humidity	95% @ 40 °C (non-condensing)	
	Vibration during Operation	With SSD: 3 Grms, IEC60068-2-64, random, 5-500 Hz, 1hr/axis (with Wall Mount)	
	Shock during Operation	With SSD: 30 G, IEC-60068-2-27, half sine, 11 ms duration (with Wall Mount)	
	EMC	CE/FCC Class B, CCC, UKCA, BSMI	
Safety	UL, CB, CCC, UKCA		

Dimensions

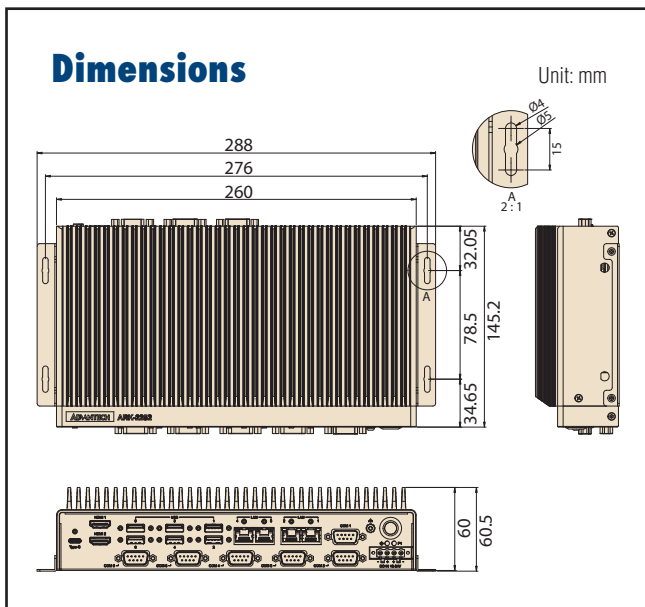

Front Panel External I/O View

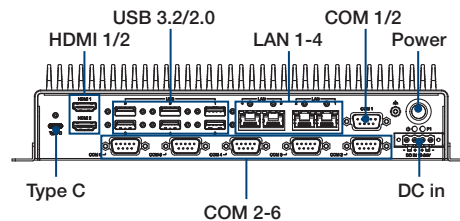

Rear Panel External I/O View

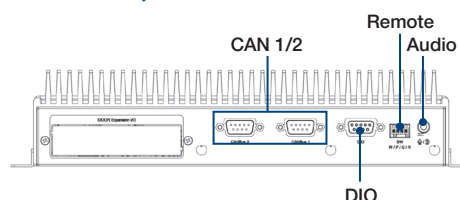

Ordering Information

Part No.	CPU	RAM	HDMI	TypeC DP	LAN	COM	USB	M.2 B	M.2 E	M.2 M	SIM	Option Module
ARK-2252-U1A1	Ultra 5 325	2 socket (up to 128G)	2	1	4	6	4 x USB 3.2 2 x USB 2.0	1	1	1	1	5G/WiFi/iDoor/PoE
ARK-2252-S9A1	Ultra 7 358H	2 socket (up to 128G)	2	1	4	6	4 x USB 3.2 2 x USB 2.0	1	1	1	1	5G/WiFi/iDoor/PoE
ARK-2252-U1A1U	Ultra 5 325	2 socket (up to 128G)	2	1	4	6	4 x USB 3.2 2 x USB 2.0	1	1	1	1	5G/WiFi/iDoor/PoE
ARK-2252-S9A1U	Ultra 7 358H	2 socket (up to 128G)	2	1	4	6	4 x USB 3.2 2 x USB 2.0	1	1	1	1	5G/WiFi/iDoor/PoE

* P/N with alphabet "U" as suffix are Made in TW

Packing List

Part Number	Description
-	1 x ARK-2252 Unit
-	1 x User Manual (Simplified Chinese)
-	1 x China RoHS
-	2 x second memory pad
1652003234	1 x 4-pin plug-in block for power in
1652007880-01	1 x 4-pin plug-in block for remote switch
1960071555N031	2 x mounting bracket
36WSPDOBD0211	Trellix, Acronis
36WSPDOBDUND11	WISE-PaaS/DeviceOn Client Bundle

Embedded OS

Part Number	Description
TBD	Win 11
TBD	Ubuntu

Optional POE modules

Part Number	Description
AMO-M021	POE Module A1 Single 30W w/ HS for ARK-2252
AMO-M022	POE Module A1 dual 15.4W w/ HS for ARK-2252

1: 30W PoE can be supported by LAN3 only
2: 15W PoE can be supported by LAN3 and LAN4

Optional thermal kit for 5G and Hailo module

Part Number	Description
AMK-A0067	Thermal kit of ARK-2252 for 5G and Hailo AI B Key

Optional Items

Part Number	Description
96PSA-A230W24P4-3	ADP A/D 100-240V 230W 24V C14 TERMINAL BLOCK 4P
1702002600	Power cable 3-pin 183cm, USA type
1702002605	Power cable 3-pin 183cm, EU type
1702031801-11	Power cable 3-pin 183cm, UK type
1700000237	Power cable 3-pin 183cm, PSE type
1700001714	Power cable 3-pin 183cm, Taiwan BSMI
AMK-V019E	VESA mount kits
AMK-R005E	DIN Rail mount kits

Optional modules for iDoor

Part Number	Description
96PSA-A230W24P4-3	ADP A/D 100-240V 230W 24V C14 TERMINAL BLOCK 4P
PCM-34D4R2	Non-Isolated RS-232, DB37x1, M.2 Bkey(2242, USB)
PCM-34D2R2	Isolated RS-232, DB9 x2, M.2 Bkey(2242, USB)
PCM-34R1TP	Intel I225, 2.5Gb/s, IEEE 1588, TSN, RJ45*1, M.2
PCM-34R2GL-AE	2 Port Giga LAN Intel i350, M.2 B+M key
AMK-A0066	ARK-2252 2xUSB port expansion Kit

- PCM IO module need to add side bracket
 - 1x 1960065854N002 (bracket)
 - 2x 19310305C0 (screw)
- PCN M.2 2242/3042 idoor main board need to assembled with expansion bracket
 - 1x 1960110006N010 (expansion bracket)
 - 1x 193B0305E2 (M3x5L screw)

Inference Kit | Production-Ready AI Inference on Edge Devices

Provides a unified and hardware-aligned runtime for deploying and validating AI inference on edge devices

It simplifies integration across CPUs, GPUs, and AI accelerators while enabling performance benchmarking and compatibility verification on target hardware. Designed for production use, Inference Kit helps hardware partners ensure stable, scalable, and repeatable AI deployment across product lines.



ADANTECH

Edge AI SDK Inference Kit

Streamlined Edge Inference

- Ready-to-Run Inference Runtime
- Accelerator-Aware Optimization
- Stable Edge Production Stack
- Unified Inference Interfaces

Benefits and Features



Unified Inference Runtime

- Consistent inference across CPUs, GPUs, and accelerators
- Vendor-optimized runtime integration
- Built-in UniInfra acceleration framework
- Optimized inference pipelines and runtime efficiency



Hardware Validation

- Benchmarking on target devices
- OS and accelerator compatibility validation
- Performance and stability verification



Production-Ready Deployment

- Stable, long-running inference operation
- System monitoring and observability support
- Designed for scalable edge deployment



Global Customer Support

- System reliability certification
- Inference computing enablement
- Edge-to-cloud scalability collaboration

