

ARK-2252

Intel® Core™ Ultra Series 3 PTL processors Fanless Box PC

Preliminary



Features

- Intel® Core Ultra Panther Lake Processor
- DDR5-6400/7200 CSODIMM memory support up to 128G
- M.2 E Key, B Key and M Key for storage and wireless module installation
- Up to 4 x Intel GbE, 6 x serial ports, 8-bit DIO, 2xCANBus
- TPM on board for system security
- 3 displays with 2 x 4K HDMI, 1x4K typeC
- 4 x USB 3.2 and 2 x USB 2.0
- 12V~24V wide range power input
- 20 ~ 60 °C extended operating temperature
- Support Advantech idoor, POE module
- Support Edge AI SDK, WEDA



Specifications

| | | | |
|-------------------|----------------------------|--|--|
| Processor System | CPU | Intel® Core™ Ultra 7 - 358H (12Xe) | Intel® Core™ Ultra 5 - 325 (4Xe) |
| | Frequency | 1.9GHz up to 4.8GHz | 2.1GHz up to 4.5GHz |
| | Core Number | 16 | 8 |
| | BIOS | AMI EFI 512 Mbit | |
| | AI Capability | Up to 180 TOPS | Up to 95 TOPS |
| Memory | Technology | DDR5 6400/7200 MT/s CSODIMM | DDR5 6400 MT/s CSODIMM |
| | Max capacity | Up to 128 GB | |
| | Socket | 2x 262-pin SODIMM (no support ECC) | |
| Graphics | Chipset | Intel® Xe 3 LPG up to 192EU (12Xe) Intel® Xe 3 LPG (4Xe) | |
| | HDMI | 2x HDMI 2.1 TMDs: 3840x2160@ 60Hz | |
| | TypeC DP | 1x DP via USB Type C Alt mode: 3840x2160@ 60Hz | |
| | Triple Display | 2 x HDMI + 1 x Type C DP | |
| Ethernet | LAN1 | 10/100/1000/2500 Mbps Intel i226V GbE, support Wake On LAN | |
| | LAN2 | 10/100/1000/2500 Mbps Intel i226V GbE, support Wake On LAN | |
| | LAN3 | 10/100/1000/2500 Mbps Intel i226V GbE, support Wake On LAN, support PoE module | |
| | LAN4 | 10/100/1000/2500 Mbps Intel i226V GbE, support Wake On LAN, support PoE module | |
| Audio | Interface | 1x, (Mic-in or Line-out, by Realtek ALC888S, modified by OS) | |
| I/O Interface | Serial Ports | 2 x RS232/422/485 (default: RS-232, default support High speed COM), modified by BIOS 4 x RS232/485 (6 wires), (default: RS-485) modified by Jumper and BIOS | |
| | USB Ports Type A | 4 x USB3.2 Gen2 (w. Cable locking mechanism) 2 x USB2.0 (w. Cable locking mechanism) 1 x internal USB 2.0 Type A for security dongle (cannot co-exist w/ iDoor or PoE) | |
| | USB Port Type C | 1x USB Type C w/ USB4, DP alt mode, 5V-3A | |
| | GPIO | 8-bit Programmable DIO | |
| | CANBus | 2x CANBus 2.0 | |
| | Expansion | M.2 | 3x, 1 x Key-B 3042/ 3052 (PCIe Gen4 x2, USB3.2) w. 1 x with nano SIM holder, for 5G/AI/idoor module 1 x Key-E 2230 (PCIe Gen4 x1, USB2.0) for WiFi Module 1 x Key-M 2280 (PCIe Gen5 x4) |
| Storage | NVMe | Default: 1x M.2 2280 M key (PCIe Gen5 x4) Optional: 1x M.2 2242 B key (PCIe Gen4x2) (modified by Switch) support Intel SW RAID up to 512G | |
| Other | WatchDog Timer | 255 levels timer interval, setup by software | |
| | TPM | TPM2.0, NPCIT764AAEYX FW7.2.4.1 | |
| Software Support | Microsoft Windows | Windows 11 (LTSC) | |
| | Linux | by project support | |
| Power Requirement | Power Type | ATX/AT (default ATX) | |
| | Power Input Voltage | 12-24 V _{DC} | |
| Power Consumption | Typical (OS idle mode) | 358H: 16.8W; 325: 18.3W | |
| | Max. (Full loading) | 358H: 36.7W; 325: 34.1W | |
| Mechanical | Construction | Aluminum housing | |
| | Mounting | DIN-rail/Wall Mount/VESA Mount | |
| | Dimensions (W x H x D) | 260 x 60 x 145 mm | |
| | Weight | 2.675 kg | |
| Environment | Operating Temperature | With extended temp. peripherals: -20 ~ 60° C with 0.7m/s air flow | |
| | Storage Temperature | -40 ~ 85 °C (-40 ~ 185°F) | |
| | Relative Humidity | 95% @ 40 °C (non-condensing) | |
| | Vibration during Operation | With SSD: 3 Grms, IEC60068-2-64, random, 5-500 Hz, 1hr/axis (with Wall Mount) | |
| | Shock during Operation | With SSD: 30 G, IEC-60068-2-27, half sine, 11 ms duration (with Wall Mount) | |
| | EMC | CE/FCC Class B, CCC, UKCA, BSMI | |
| Safety | UL, CB, CCC, UKCA | | |

Dimensions

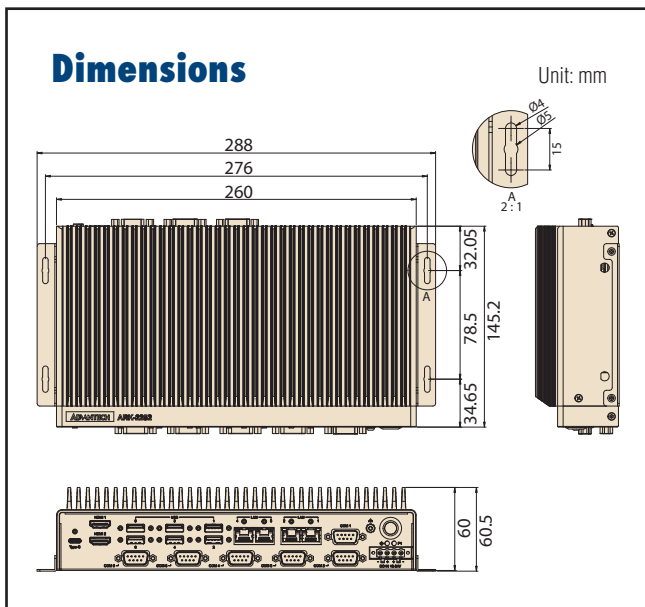

Front Panel External I/O View

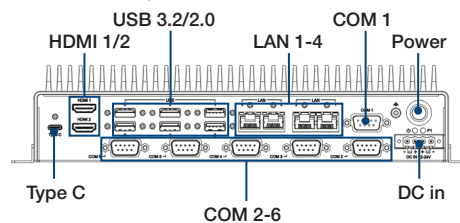

Rear Panel External I/O View

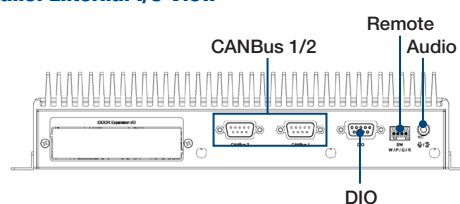

Ordering Information

| Part No. | CPU | RAM | HDMI | TypeC DP | LAN | COM | USB | M.2 B | M.2 E | M.2 M | SIM | Option Module |
|----------------|--------------|-----------------------|------|----------|-----|-----|----------------------------|-------|-------|-------|-----|-------------------|
| ARK-2252-U1A1 | Ultra 5 325 | 2 socket (up to 128G) | 2 | 1 | 4 | 6 | 4 x USB 3.2 2 x USB 2.0 | 1 | 1 | 1 | 1 | 5G/WiFi/iDoor/PoE |
| ARK-2252-S9A1 | Ultra 7 358H | 2 socket (up to 128G) | 2 | 1 | 4 | 6 | 4 x USB 3.2 2 x USB 2.0 | 1 | 1 | 1 | 1 | 5G/WiFi/iDoor/PoE |
| ARK-2252-U1A1U | Ultra 5 325 | 2 socket (up to 128G) | 2 | 1 | 4 | 6 | 4 x USB 3.2 2 x USB 2.0 | 1 | 1 | 1 | 1 | 5G/WiFi/iDoor/PoE |
| ARK-2252-S9A1U | Ultra 7 358H | 2 socket (up to 128G) | 2 | 1 | 4 | 6 | 4 x USB 3.2 2 x USB 2.0 | 1 | 1 | 1 | 1 | 5G/WiFi/iDoor/PoE |

* P/N with alphabet "U" as suffix are Made in TW

Packing List

| Part Number | Description |
|----------------|---|
| - | 1 x ARK-2252 Unit |
| - | 1 x User Manual (Simplified Chinese) |
| - | 1 x China RoHS |
| - | 2 x second memory pad |
| 1652003234 | 1 x 4-pin plug-in block for power in |
| 1652007880-01 | 1 x 4-pin plug-in block for remote switch |
| 1960071555N031 | 2 x mounting bracket |
| 36WSPDOBD0211 | Trellix, Acronis |
| 36WSPDOBUND11 | WISE-PaaS/DeviceOn Client Bundle |

Embedded OS

| Part Number | Description |
|-------------|-------------|
| TBD | Win 11 |
| TBD | Ubuntu |

Optional POE modules

| Part Number | Description |
|-------------|---|
| AMO-M021 | POE Module A1 Single 30W w/ HS for ARK-2252 |
| AMO-M022 | POE Module A1 dual 15.4W w/ HS for ARK-2252 |

- 30W PoE can be supported by LAN4 only
- 15W PoE can be supported by LAN3 and LAN4
- Cannot co-exist w/ internal USB 2.0 or iDoor

Optional thermal kit for 5G and Hailo module

| Part Number | Description |
|-------------|---|
| AMK-A0067 | Thermal kit of ARK-2252 for 5G and Hailo AI B Key |

1. Condition may apply, contact your representative for further information

Optional Items

| Part Number | Description |
|-------------------|---|
| 96PSA-A230W24P4-3 | ADP A/D 100-240V 230W 24V C14 TERMINAL BLOCK 4P |
| 1702002600 | Power cable 3-pin 183cm, USA type |
| 1702002605 | Power cable 3-pin 183cm, EU type |
| 1702031801-11 | Power cable 3-pin 183cm, UK type |
| 1700000237 | Power cable 3-pin 183cm, PSE type |
| 1700001714 | Power cable 3-pin 183cm, Taiwan BSMI |
| AMK-V019E | VESA mount kits |
| AMK-R005E | DIN Rail mount kits |

Optional modules for iDoor

| Part Number | Description |
|-------------------|--|
| 96PSA-A230W24P4-3 | ADP A/D 100-240V 230W 24V C14 TERMINAL BLOCK 4P |
| PCM-34D4R2-AE | Non-Isolated RS-232, DB37x1, M.2 Bkey(2242, USB) |
| PCM-34D2R2-AE | Isolated RS-232, DB9 x2, M.2 Bkey(2242, USB) |
| PCM-34R1TP-AE | Intel I225, 2.5Gb/s, IEEE 1588, TSN, RJ45*1, M.2 |
| PCM-34R2GL-AE | 2 Port Giga LAN Intel i350, M.2 B+M key |
| AMK-A0066 | ARK-2252 2xUSB port expansion Kit |

- PCM IO module need to add side bracket
 - 1x 1960065854N002 (bracket)
 - 2x 19310305C0 (screw)
- PCN M.2 2242/3042 iDoor main board need to assembled with expansion bracket
 - 1x 1960110006N010 (expansion bracket)
 - 1x 193B0305E2 (M3x5L screw)
- Cannot co-exist w/ internal USB 2.0 or PoE

Inference Kit | Production-Ready AI Inference on Edge Devices

Provides a unified and hardware-aligned runtime for deploying and validating AI inference on edge devices

It simplifies integration across CPUs, GPUs, and AI accelerators while enabling performance benchmarking and compatibility verification on target hardware. Designed for production use, Inference Kit helps hardware partners ensure stable, scalable, and repeatable AI deployment across product lines.

ADVANTECH

Edge AI SDK Inference Kit

Streamlined Edge Inference

- Ready-to-Run Inference Runtime
- Accelerator-Aware Optimization
- Stable Edge Production Stack
- Unified Inference Interfaces

Benefits and Features



Unified Inference Runtime

- Consistent inference across CPUs, GPUs, and accelerators
- Vendor-optimized runtime integration
- Built-in UniInfra acceleration framework
- Optimized inference pipelines and runtime efficiency



Hardware Validation

- Benchmarking on target devices
- OS and accelerator compatibility validation
- Performance and stability verification



Production-Ready Deployment

- Stable, long-running inference operation
- System monitoring and observability support
- Designed for scalable edge deployment



Global Customer Support

- System reliability certification
- Inference computing enablement
- Edge-to-cloud scalability collaboration



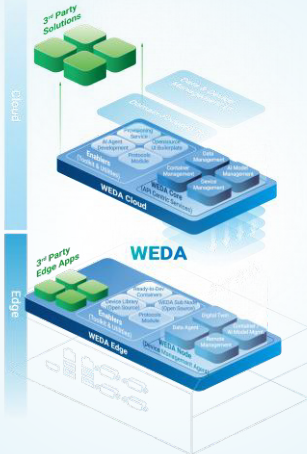

Features

- API-Centric design
- Centralized edge device management
- MLOps, Digital twin interface
- Container / AI model management & remote deployment
- Universal physical AI integration framework
- Silicon-optimized Ready-to-Dev Container Library
- Hardened remote orchestration & security

Introduction

WEDA (WISE-Edge Developer Architecture)

A revolutionary framework designed to transform Advantech’s hardware into a seamlessly programmable platform for next-generation AI Agents.

WEDA Edge: High-Performance Silicon Optimization As an advanced edge device powered by **WEDA Node**, WEDA Edge unifies Advantech’s extensive hardware portfolio—spanning NVIDIA, Qualcomm, x86, and ARM platforms—via "Ready-to-Dev" Containers. These environments eliminate driver-configuration friction, enabling AI models to instantly leverage maximum GPU/NPU acceleration. Complementing this, the Advantech Device Library consolidates complex drivers into a unified Advantech.WEDA namespace. This cross-silicon integration allows developers and AI Agents to command hardware with unprecedented simplicity, transforming edge infrastructure into a performance-optimized asset.

WEDA Cloud: The Command Center for AI Lifecycles Driven by **WEDA Core**, the WEDA Cloud service serves as the centralized nerve center for managing massive device networks and Digital Twin systems. The platform orchestrates the entire AI lifecycle through key capabilities:

Zero-Touch Deployment: Devices self-register upon power-up via Digital Twin protocols for instant global deployment.

Autonomous Container Orchestration: AI Agents abstract physical logistics to manage logical devices, autonomously pushing updates and monitoring container health across thousands of nodes via Shadow technology and Stack templates.

AI Model Governance & Security: Ensures high-fidelity data flow and robust model management, while encrypted repositories safeguard intellectual property across the entire fleet.

