

BB-US09ML2-2P

BB-US09ML2-4P

Isolated USB 2 or 4 Port RS-232 Converters



Features

- Connect multiple RS-232 devices to your USB port
- 2000 V RMS optical isolation
- RS-232 data rates up to 460.8 kbps
- Supports USB 2.0 (backward compatible), 12 Mbps
- Desk or panel mount (flanges attached)
- USB port-powered or external power supply (not included, sold separately)
- High retention USB port ensures reliable connections
- Includes one USB cable, 2 m (6 ft)

Introduction

Universal Serial Bus (USB) has become the connectivity workhorse of today's PCs, replacing the familiar serial ports. However, many commercial and industrial devices still use the RS-232 interface. To connect these devices to modern PCs and provide protection from electrical transients, you need a simple and reliable conversion solution.

Connect legacy RS-232 devices to a USB port with 2000 V RMS port-to-port optical isolation from voltage spikes and ground loops.

Models BB-US09ML2-2P and BB-US09ML2-4P offer this solution. Simply plug the converter into an available USB port on your computer or USB hub and install the drivers. Automatic configuration - the device will show up as additional COM ports in the Windows Device Manager which are fully compatible with your Windows applications. A USB cable is included.

Powered can be supplied by USB port powering or an external power source (not included, sold separately).

Ordering Information

Model No.	Description	Number of Ports
BB-US09ML2-2P	Isolated USB to RS-232 Converter	2
BB-US09ML2-4P	Isolated USB to 232 Converter	4

Accessories – Sold Separately

- BB-MDR-20-24 – Power supply, 24 VDC, 1 A, DIN rail mount
- BB-USBAMB-3F – USB cable, 1 m (3 ft)
- BB-USBAMB-6F – USB cable, 2 m (6 ft) (one included)
- BB-9PAMF6 – 2 m (6 ft) DB9 male to DB9 female cable
- BB-9PAMF10 – 3 m (10 ft) DB9 male to DB9 female cable
- BB-232NM9 – 3 m (6 ft) DB9 female to DB9 female null modem cable
- BB-232NM9MF10 – 3 m (10 ft) DB9 male to DB9 female null modem cable
- BB-TBKT1 – Replacement terminal block, 2-position, 5.08mm, 8A, 300V

Specifications

Serial Technology	
RS-232 Configuration	DTE
RS-232 Connector	DB9 male (DTE)
Data Rate	460.8 kbps, maximum
Isolation	2000 V optical
USB Technology	
Connector	USB Type B female, high retention withdrawal >15 N
Standard	1.1 and 2.0 compatible
Data Rate	12 Mbps
Power	
Source	USB port or external source (power supply not included, sold separately)
Input Voltage	5 VDC from USB port or 10 - 30 VDC external power supply
Consumption	Higher power device (>100 mA) BB-US09ML2-2P: 3 Watts, external power supply BB-US09ML2-4P: 5 Watts, external power supply
Software	
Driver O/S Support	Windows 10 (32/64 bit), Server 2016, Server 2019

RS-232 Pin-outs (DTE / DB9 Male)

PIN	Direction	Signal Name
1	Input	DCD (Receive Line Signal Detector)
2	Input	RD (Receive Data)
3	Output	TD (Transmit Data)
4	Output	DTR (DTE Ready)
5	n/a	SG (Signal Ground)
6	Input	DSR (DCE Ready)
7	Output	RTS (Request to Send)
8	Input	CTS (Clear to Send)
9	Input	RI (Ring Indicator)

Specifications – continued

Mechanical	
Dimensions – with flanges	19.10L x 7.09W x 2.95H cm (7.52L x 2.79W x 1.16H in)
Weight	BB-US09ML2-2P: 331.1 g (0.73 lb) BB-US09ML2-4P: 349.3 g (0.77 lb)
Environmental	
Operating Temperature	0 to +70 °C (+32 to +158 °F)
Storage Temperature	-40 to +85 °C (-40 to +185 °F)
Operating Humidity	0 to 95%, non-condensing
Meantime Between Failures (MTBF)	
MTBF	BB-US09ML2-2P: 118245 hours BB-US09ML2-4P: 61861 hours
MTBF Method	Parts Count Reliability Prediction
Regulatory – Approvals / Standards / Directives	
FCC, UL508	
CE Standards	EMC: EN 55032 Class B - Electromagnetic compatibility of multimedia equipment –Emission requirements EN 55024 - Information Technology Equipment – Immunity Characteristics – Limits and methods of measurement
CE Directives	2014/30/EU Electromagnetic Compatibility Directive 2011/65/EU amended by (EU) 2015/863 Reduction of Hazardous Substances Directive (RoHS) 2012/19/EU Waste Electrical and Electronic Equipment (WEEE)

Mechanical Diagram - BB-US09ML2-2P

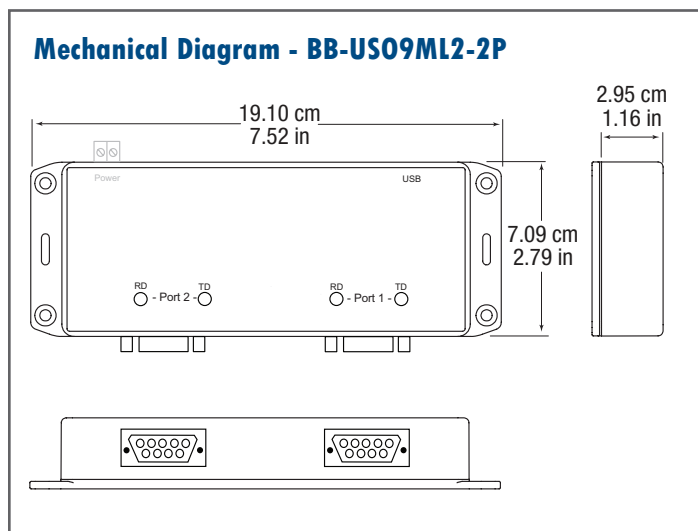

Mechanical Diagram - BB-US09ML2-4P

