

LEO-S592-AQ

LoRaWAN 7 in 1 AQI Sensor



Features

- Integrated with multiple sensors: humidity, temperature, CO2, Brightness, PM2.5, PM10, HCHO.
- Multiple display modes and clear emoticon to easily understand the comfort levels via screen
- Equipped with LED indicator and buzzer to indicate device status and threshold alarms
- Compliant with standard LoRaWAN® gateways and network servers

Specifications

Display	4.2" B/W epaper
Frequency	US915/AU915/KR920/AS923/RU864/IN865/EU868/CN470
NFC	Y (Configuration)
LED	R/O/G
Button	1 x Power Button 1 x Reset Button
Power	5V/1A by Type-C Port
Working Temperature	-20°C ~ 60°C ePaper (0°C ~ 40°C)
Working Humidity	10% ~ 90% (non-condensing) at 25°C (77°F)
Wireless Range	50 meters+ (Line of Sight)**
dimension	100.8 x 114 x 22 mm (3.97 x 4.49 x 0.87 in)
Weight (KG)	0.68g
IP	30
Certification	FCC, CE, RCM
Temperature	Range -40°C ~ 85°C
	Accuracy ±1°C
	Resolution 0.1°C
Humidity	Range 0~100% RH
	Accuracy ±3%
	Resolution 0.50%
CO2	Range 400~2000PPM
	Accuracy 50PPM± 5%
	Resolution 1PPM
Brightness	Range 60000 lux
PM2.5/PM10	Range 0 ~ 1000 µg/m ³
	Accuracy 0~100 (±10 µg/m ³) 100~1000 (±10 %)
	Resolution 1 µg/m ³
HCHO*	Range 0 ~ 6 mg/m ³
	Accuracy ±10 %
	Resolution 0.01 mg/m ³

* HCHO sensor working life is 5 years, support replacement.

** Test under laboratory conditions and for guideline purposes only

Dimensions

Unit: mm

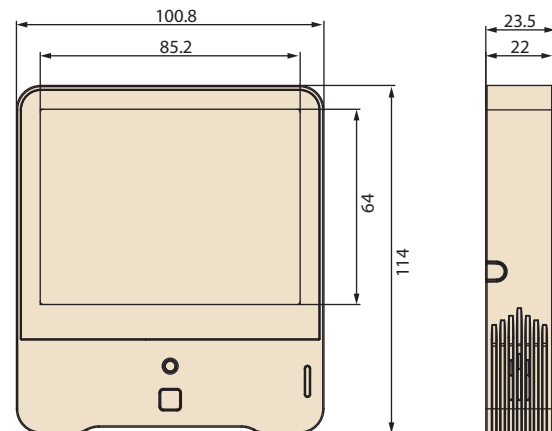

Ordering Information

Part Number	Description
LEO-S592-AQG0	LEO-S LoRaWAN 7 in 1 AQI sensor 915
LEO-S592-AQCO	LEO-S LoRaWAN 7 in 1 AQI sensor 470
LEO-S592-AQE0	LEO-S LoRaWAN 7 in 1 AQI sensor 868

Packing List

- 1 x Type -C Cable
- 1 x USB Adapter
- 1 x Mounting Bracket
- 1 x 3M Double Side Tape
- 3 x Wall Mounting screws

USM-S67

LoRaWAN Gateway



Features

- Quad-core industrial processor with big memory
- Equip with SX1302 chip, handling a higher amount of traffic with lower consumption
- 8 half/full-duplex channels
- IP65 enclosure and industrial design for parts of outdoor environment applications like eaves
- Desktop, wall or pole mounting
- Multi backhaul backups with Ethernet and Wi-Fi
- Easy and centralized management of remote devices
- Enable security communication with multiple VPNs like IPsec/OpenVPN/L2TP/PPTP/DMVPN
- Built-in network server and MQTT/HTTP/HTTPS API for easily integration
- Embedded Python SDK for users secondary development
- Fast and user-friendly programming by Node-RED development tool

Specifications

General	CPU	Quad-core 1.5 GHz, 64-bit ARM Cortex-A53
	Memory	512 MB DDR4
	Flash	8 GB eMMC
	LED Indicators	1 x POWER, 1 x STATUS, 1 x LoRa, 1 x Wi-Fi, 1 x Ethernet
LoRaWAN	Frequencny	US915/AU915/KR920/AS923/RU864/IN865/EU868/CN470
	Antenna	2 x Internal Antennas 1 x External Antenna
	Wireless Range	100 meters+ (Line of sight)**
	Connect Q'ty	Support up to 100 x LEO-S sensors*
Connectivity	Ethernet	10/100/1000 Base-T
	Wifi	IEEE 802.11 b/g/n, 2.4GHz
Others	Button	1 x Reset Button
	Power	1. DC Jack Connector for 9-24 V _{DC} power supply 2. 1 x 802.3 af PoE input
	Working Temperature	-40 ~ 70°C (-40 ~ 158°F)
	Storage Temperature	-40 ~ 85°C (-40 ~ 185°F)
	Operating Humidity	0 ~ 95% (non-condensing) at 25°C (77°F)
	dimension	180 x 110 x 56.5 mm (7.09 x 4.33 x 2.22 in)
	IP	65
Certification	FCC, TELECOM, CE, KC, RCM, SIRIM, NBTC	

* Dependent on usage scenario

** Test under laboratory conditions and for guideline purposes onl

Dimensions

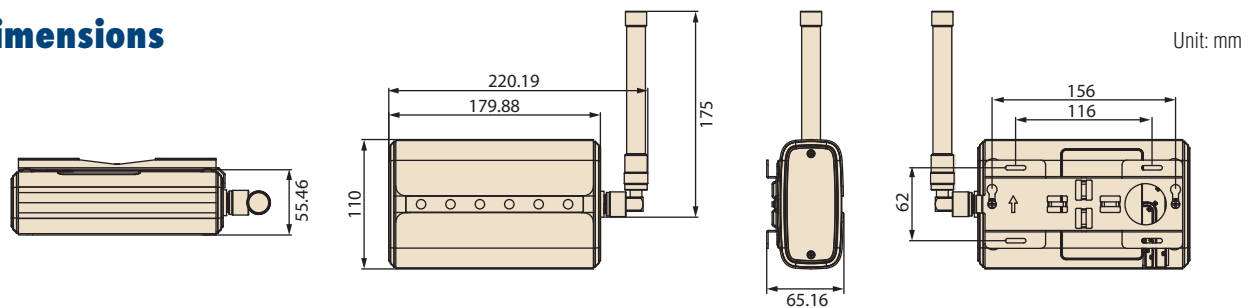

Ordering Information

Part Number	Description
USM-S67-G0WPO	USM-S67 LoRaWAN & WIFI Gateway 915
USM-S67-C0WPO	USM-S67 LoRaWAN & WIFI Gateway 470
USM-S67-E0WPO	USM-S67 LoRaWAN & WIFI Gateway 868

Packing List

- 1 x LAN Cable(1.5M)
- 1 x Adapter
- 1 x Mounting Bracket
- 2 x Mounting Kits
- 1 x LoRaWAN Antenna

USM-S67

LoRaWAN Compact Gateway

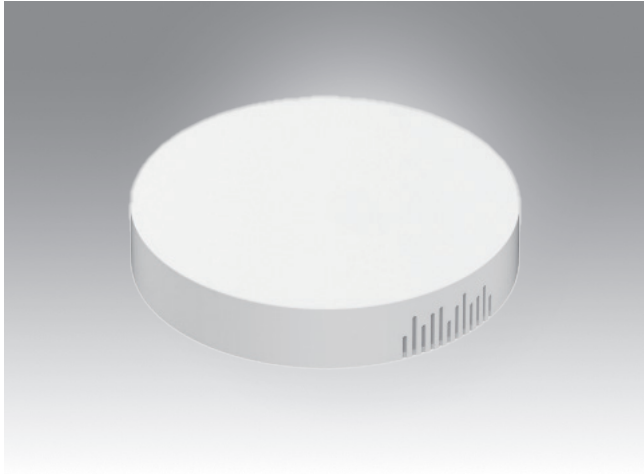

Features

- Support 8 half/full-duplex channels
- Enable security communication with multiple VPNs(IPsec/OpenVPN/L2TP/PPTP/DMVPN)
- Detect and analyze the noise level and provide intuitive diagram for deployment
- Built-in network server and MQTT/HTTP/HTTPS API for easily integration

Specifications

General	CPU	528 MHz, ARM Cortex-A7
	Memory	256 MB DDR4
	Flash	4 GB eMMC
	LED Indicators	1 x SYS, 1 x LoRa
LoRaWAN	Frequency	US915/AU915/KR920/AS923/CN470
	Antenna	2 x Internal Antennas
	Wireless Range	100 meters+ (Line of sight)**
Connectivity	Connect Q'ty	Support up to 20 x LEO-S sensors*
Others	Ethernet	10/100 Base-T
	Button	1 x Reset Button
	Power	1.802.3 af PoE input 2.5V/1A by Type-C Port
	Working Temperature	-20 ~ 50°C (-4 ~ 122°F)
	Storage Temperature	-40 ~ 85°C (-40 ~ 185°F)
	Operating Humidity	0 ~ 95% (non-condensing) at 25°C (77°F)
	dimension	Ø115 x 21 mm (Ø4.52 x 0.83 in)
	IP	30
Certification	FCC, TELEC, CE***	

* Dependent on usage scenario

** Test under laboratory conditions and for guideline purposes only

***CE by project

Ordering Information

Part Number	Description
USM-S67-G00P0	USM-S67 LoRaWAN Gateway 915
USM-S67-C00P0	USM-S67 LoRaWAN Gateway 470

Packing List

- 2 x Mounting Kits

Dimensions

Unit: mm

