

# PWS-770

## 10.4" Rugged Tablet with Intel® Atom™ N2600



### Features

- 10.4" XGA LED panel, WAV transfective-LCD, high brightness 300 cd/m<sup>2</sup>
- Hot swap, high capacity Li-ion battery provides 8 hours of operation<sup>(1)</sup>
- Rich array of I/O ports supports a variety of applications
- IP54-certified, 4ft drop proof
- Complete communication: Wi-Fi/Bluetooth/GPS/WWAN (3.75G)
- Optional data capture modules: 1D/ 2D barcode scanner / MSR / RFID
- Lightweight, 1.2 kg



### Introduction

The PWS-770 is a rugged mobile tablet featuring a 10.4" XGA resolution TFT LCD panel and an Intel® Atom™ N2600 1.6 GHz processor. It comes with 802.11 b/g/n WiFi, Bluetooth 4.0, a 2M pixel camera. It also has built-in optional GPS and WWAN 3.75G antenna. PWS-770 optional devices include an RFID module with antenna, a 1D/2D barcode scanner and an MSR card reader. PWS-770 is a fully functional communication device suitable for any outdoor application. It carries an IP54 rating for protection against dirt, dust and water. PWS-770 can also survive a 4-foot drop. Advantech's PWS-770 is a strong tablet PC for industrial and commercial use in any environment.

### Specifications

Motherboard	CPU	Intel Atom N2600/1.6 GHz	
	Chipsets	Intel NM10	
	Memory	SODIMM DDRIII to 2 GB	
	Storage	Supports mSATA SSD 32 GB ~ 128 GB	
Display & Touchscreen	Display	10.4" XGA (1024 x 768) (Transflective) LCD 300 cd/m <sup>2</sup> LED back light	
	Touch Panel	4-wire resistive touch panel	
System	Wireless Communication	802.11b/g/n WLAN (default); 802.11 a/b/g/n (optional) Bluetooth 4.0 class2 GPS (u-blox 6; 50-channel; supports GALILEO); WWAN (Cinterion PH8)	
	Camera	CMOS 2.0M pixel Camera module	
	Security	1. Password security 2. TPM 1.2 (Optional)	
	Application Buttons	Power button x 1 Function keys x 3 (F1-F3) Tablet PC keyboard x 1 Mode key x 1	Enter key x 1 Activate key x 2 ( S1 & S2 ): Activate barcode reader, camera & dimming adjustment required to control the brightness
	LED Status Indicator	Power LED (Green/Yellow) x1 Storage LED (Green) x1	WLAN LED (Green) x1
	I/O Interfaces	USB 2.0 x 2 Serial port RS-232 x 1 VGA port x 1 Audio in jack x 1 Audio out jack x 1	Internal mono microphone x 1 DC-in x 1 Docking port (32-pin; USB/PCIE/DC) SIM slot (with WWAN option)
	Audio Output	1 Watt speaker x 2	
	Expansion Port	SD memory card x 1 (SD 2.0/SDHC)	
	Battery	Internal battery: 3S1P 11.1V 1880mAh Hot-Swap External Battery: 11.1V 3760/5000mAh (Optional)	
	DC Input	19V 1± 5%	
OS Support	Windows 7 Professional /Embedded		
Optional Devices	Data Collection	CMOS 2.0M pixel Camera module (default); 5.0M pixel Camera (optional) 1D/2D Barcode MSR; HF RFID	
Environmental Specifications	Temperature & Humidity	Operating Temperature: -20° C (*2) ~ 50° C (Charge: 0° C ~ 40° C for the battery protection) Storage Temperature -30° C ~ 60° C Operating Humidity 5% ~ 95% @ 40° C	
	IP Rating	IP54	
	Drop	4-foot drop onto Plywood, MIL-STD-810G 516.5 Procedure VI	
	Vibration	MIL-STD-810G, EN50155 certified	

(1) - Internal battery + external 2nd battery 5000mAh in Battery Mark with maximum peripherals connected (Wi-Fi & BT enabled) the battery life up to 7.5hrs

- Internal battery + external 2nd battery 5000mAh idle with minimum peripherals connected in OS (Wi-Fi & BT disabled) the battery life up to 8.5 hrs

(2) Battery life and charge cycles vary by use and settings.

## Dimensions

Unit: mm

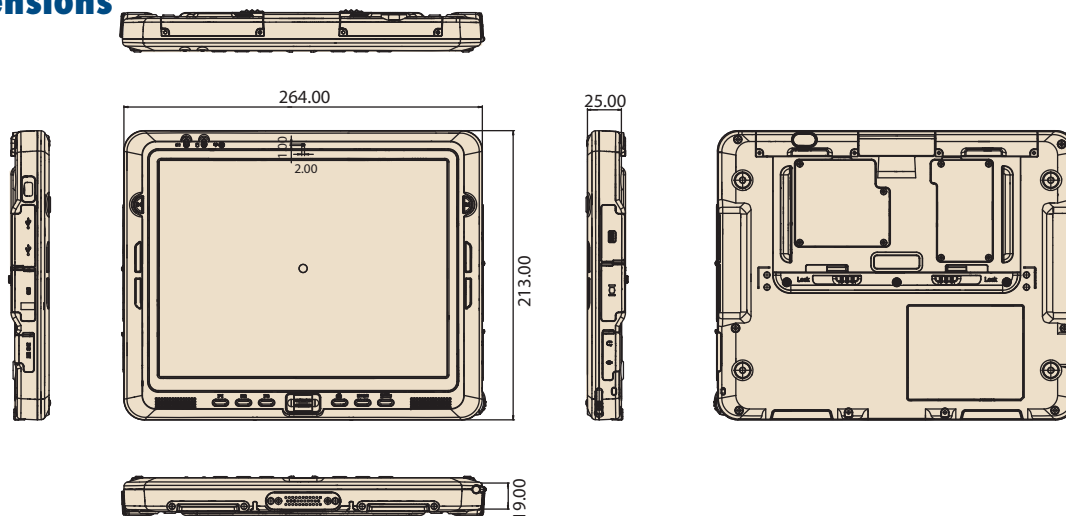

## Specifications Cont.

Certifications	EMC	CE/FCC/CCC/BSMI/C-Tick/PTCRB
	Safety	UL/CE/CB/CCC
Dimensions & Weight	Dimensions	264 (L) x 213 (W) x 18 (H) mm
	Weight	Under 1.2 kg without rubber bumper & optional devices

## I/O Connectors

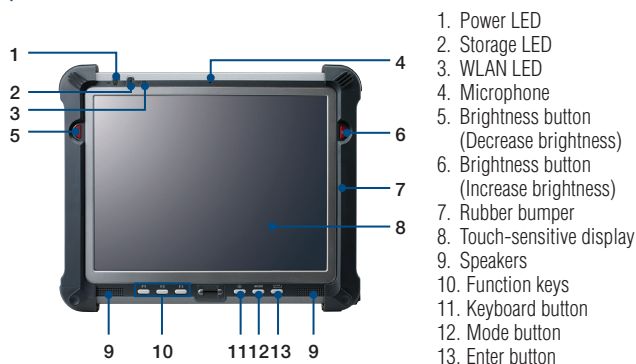

## Ordering Information

### Standard Configuration

Part Number	Description
PWS-770-S3A0EC001E	PWS-770, 10.4 sunlight, N2600 /RAM2G/mSata32G/WL/BT/WES7
PWS-770-S3AWEC001E	PWS-770, 10.4 sunlight, N2600/RAM2G/mSata32G/WL/BT/GPS/3G/WES7
PWS-770-S3A0PC001E	10.4 Sunlight N2600 RAM2G SSD32 WL BT Win7 PRO
PWS-770-S3AWPC001E	10.4 Sunlight N2600 RAM2G SSD32 WL BT GPS 3G Win7 PRO

Note: The package are included PWS-770 table and Power adapter (not include power cord)

### Barebones (CTOS only)

Part Number	Description
PWS-770-S0A00C001E	PWS-770 Barebone, Sunlight/WL/BT
PWS-770-S0AW0C001E	PWS-770 Barebone, Sunlight/WL/BT/GPS/3G

## Accessories

Part Number	Description
S10A-93-S10A6-011	VESA mount (M6)
S10A-93-S10A6-021	VESA mount (M4)
S10A-93-S10A1-001	Carrying bag
S10A-93-S10AA-002	Handstrap
S10A-93-S10A6-001	Stand
1757002943	Adapter 100-240V 65W 19V 3.42A
PWS-770-CADAP00E	PWS-770 Car adapter ADP90DCA-M12 to Cigar Lighter (1200mm)
PWS-770-BAT100E	PWS-770 2nd Battery (3760mAh)
PWS-770-BAT200E	PWS-770 2nd Battery (5000mAh)
PWS-770-CRADLE00E	PWS-770 Desk Cradle
PWS-770-VCRADLE00E	PWS-770 Vehicle Docking Station; with LAN Cable M12(M) cable 8P/RJ45(F) (50mm)

# Accessories

## PWS-770 Vehicle Docking Station



### Features

- Integrated GPS module
- Anti-theft locking mechanism
- One second to remove; one second to install
- Ignition control
- Complement port replication
- Vibration can meet military standard, MIL-STD-810G & SAE J1455
- E-Mark Compliance

### Introduction

The PWS-770 high strength composite vehicle docking station is designed to hold PWS-770 tablet with safety, security, and efficiency in mind. The docking station comes with an anti-theft locking mechanism. It offers complete port replication for users accessing audio jacks, USB, RS-232/RS-485, and LAN ports. One of the most important and unique design features is it implements a GPS module to enhance GPS positioning, locating, and tracking ability.

### Product Specifications

Function	Item	Description
RF	GPS	U-blox 6 GPS module
IO connectors	HDC	1 x HDC connector
	HDC cable IO ports enhancement (optional)	1 RS-232, 1x RS-485, 1 x Line-in & 1 x Line-out, 2 x DI & 2 x DO
	USB	2 x USB 2.0 (locking type)
	Ethernet	1 x 100/1000 LAN port (M12)
	SMA for GPS	1 for external GPS Antenna
	DC in	1 x Power Jack (M12) 18.5V ± 5%
Environment	IP Rating	IP43 (with tablet docked)
	Operating Temperature	-10° C ~ 50° C (Charge: 0° C ~ 40° C) with tablet
	Storage Temperature	-40° C ~ 85° C
	Vibration/Shock	MIL-STD-810G, Method 514.5; SAE J1455
	EMC	CE, FCC
	Safety	UL, CB
Vehicle-related	E-Mark	
Mounting		VESA (75 x 75 mm)
Weight		804g
Dimension		204.98 x 276.99 x 85.8 mm

### Ordering Information

Part Number	Description
PWS-770-VCRADLE00E	PWS-770 Vehicle docking station, with LAN Cable M12(M) cable 8P/RJ45(F) (50mm)
PWS-770-CADAP00E	PWS-770 Car Adapter DC to DC 10-32V 90W W/O PFC (1200mm) to Cigar Lighter; M12 Plug
PWS-770-CAD1200E	PWS-770 Car Adapter DC to DC 10-32V 90W with 12V Relay (1200mm); M12 Plug
PWS-770-CAD2400E	PWS-770 Car Adapter DC to DC 10-32V 90W with 24V Relay (1200mm); M12 Plug
1700021797-01	M cable M12 5P/DC jack (10cm) to PWS-770
PWS-770-CHDC00E	PWS-770 Vehicle docking HDC Cable 36P/D-sub*2+ Line in x1 & Line Out x2 + DI x2 & DO x2 (2000mm)
PWS-770-GPSAN00E	GPS antenna N12G0002 5.5V 22mA (5m)
RAM-MOUNT-06E	5.625" double socket arm for 1.5" ball base, 3.625" VESA base at both sockets
RAM-MOUNT-07E	5.625" double socket arm for 1.5" ball base, One side is 3.625" VESA base, on the other side, the socket with flat 2.5" diameter base AMPS hole pattern

Note: PWS-770 Vehicle docking station package include LAN Cable for (M12) RJ45 connector. The car adapter is optional. Do not attempt to connect Car adapter M12 plug to PWS-770 tablet DC-in

### Bottom view IO ports



1. HDC x1: RS232 x1; RS485 x1; DIx2; DOx2; Line-in x1; Line-out x1
2. USB 2.0 x2
3. LAN 100/1000 (M12) x1
4. DC-in 19V (M12) x1
5. GPS SMA x1

### Dimensions

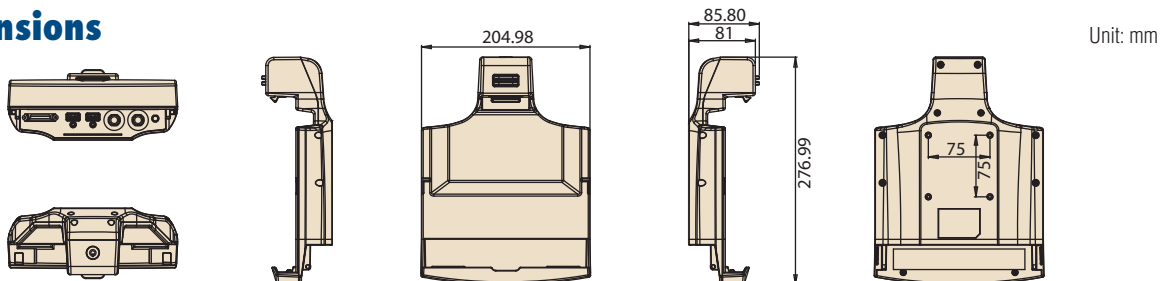

Note: In order to prevent the damage to both PWS-770 and the Vehicle docking station, please do not attempt to use with other tablets (For example: the previous model, S10A).

# Accessories

## PWS-770 Desk Docking Station



### Features

- Offers complete port replication for PWS-770
- Second battery charger
- Operating temperature -20° C to 60° C

### Introduction

The desk docking station is designed to dock PWS-770 tablet when you are at your home or on your office desk. When docked, you can charge both the internal and external batteries or transfer data from your tablet PC to another PC.

### Product Specifications

Feature	Description
Product Name	PWS-770 Desk Docking Station
External I/O Interfaces	One LAN port One RS-232 Two USB 2.0 host connectors Battery Charger for 2nd battery 11.1V 5000mAh & 3760mAh One DC-in (19 V +- 5%)
Environment	Operating Temperature -20° C ~ 60° C Storage Temperature -40° C ~ 70° C Operating Humidity 10% ~ 95%
Certifications	CE, FCC
Physical Size	205 x 150 x 98 mm
Weight	812g

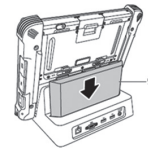

No.	Component	Function
1	LAN port	Connect an RJ-45 cable to access LAN connection
2	Serial port	Connect a serial cable to connect to another PC
3	USB ports	Connect USB connectors to transfer data
4	DC-IN	Connect the AC adapter to charge the battery
5	Charger	Battery Charger for 2nd battery

Note: In order to prevent the damage to both PWS-770 and the desk docking station, please do not attempt to use with other tablets (For example: the previous model, S10A).

### Ordering Information

Part Number	Description
PWS-770-CRADLE00E	PWS-770 Desk Docking Station
1757002943	ADAPTER 100-240V 65W 19V 3.42A

### Dimensions

Unit: mm

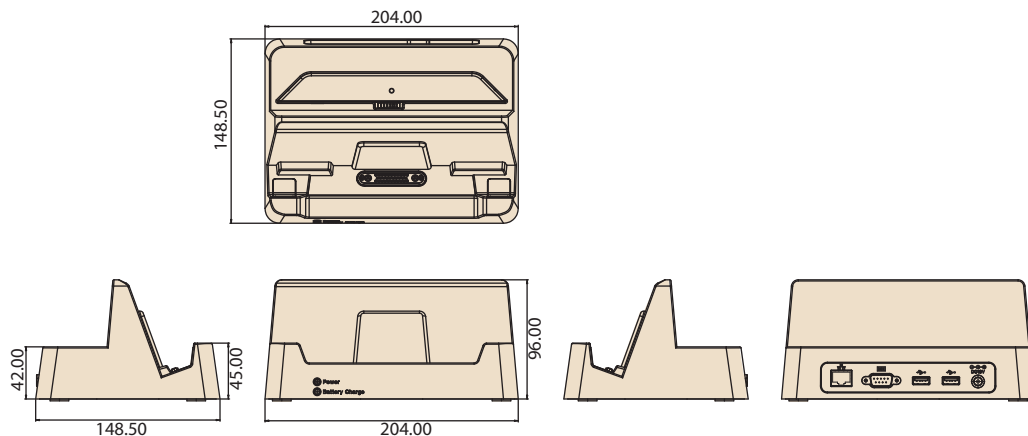

# Accessories

## Accessories for PWS-770 Series



### Features

- Carry Bag
- Hand Strap
- External Battery
- Stand
- VESA Mount

### Carry Bag



#### Features

- P/N: S10A-93-S10A1-001
- Material: PVC
- Color: Black
- Dimensions: 265 x 230 x 30 mm
- Weight: 440g

### Hand Strap



#### Features

- P/N: S10A-93-S10AA-002
- Material: PVC
- Color: Black
- Dimensions: 245 x 175 x 10 mm
- Weight: 85g

### External Battery (Small & Big)



#### Features

- |  |  |
|--|--|
| <b>Small</b>                           | <b>Big</b>                             |
| ▪ P/N: PWS-770-BAT100E (11.1V 3760mAh) | ▪ P/N: PWS-770-BAT200E (11.1V 5000mAh) |
| ▪ IP rating: IP54 With Device          | ▪ IP rating: IP54 With Device          |
| ▪ Dimensions: 181.8 x 87.6 x 18.8 mm   | ▪ Dimensions: 181.8 x 87.6 x 26.8 mm   |
| ▪ Weight: 325g                         | ▪ Weight: 382g                         |

### Multiple Battery Charger



#### Features

- P/N: PWS-770-MBC00E
- Store and charge up to 4 PWS-770 external batteries
- LEDs indicate charge status
- Easy to fix on the table by screws
- Power input: 19.5V/7.7A
- Operating temperature: 0° C ~ 40° C
- Dimension: 214.4 x 229.4 x 60 mm
- Weight: 1.4kg

### Stand



#### Features

- P/N: S10A-93-S10A6-001
- Material: SECC + Rubber
- Angle: 0~75 degree angle
- Dimensions: 207 x 117 x 12 mm
- Weight: 100g

### VESA Mount



#### Features

- P/N: S10A-93-S10A6-011 (M6)
- P/N: S10A-93-S10A6-021 (M4)
- Material: SPCC
- Color: Black
- Dimensions: 176 x 237 x 19 mm
- Weight: 306g